

- 1.0 GENERAL NOTES
 - 1.1 THIS DOCUMENT PROVIDES INSTALLATION INSTRUCTIONS FOR POWER SUPPLY UNITS MOUNTING INTO PRIMARY PSU MOUNTING LOCATION OF THE 20" POLE BASE
- 2.0 DESIGN NOTES
 - 2.1 POWER SUPPLY/RECTIFIERS SUPPLIED SEPARATELY, SHOWN FOR REFERENCE ONLY
- 3.0 MANUFACTURING/SPECIAL REQUIREMENTS
 - 3.1 TORQUE HARDWARE ACCORDING TO SIZE:
 - > M4: TORQUE 19.50 IN-LB OR 2.2 N-M
 - > M6: TORQUE 40.0 IN-LB OR 4.5 N-M
 - > M8: TORQUE 6.6 FT-LB OR 9.0 N-M
 - > M10: TORQUE 16.2 FT-LB OR 22 N-M
 - > 1/4": TORQUE 4.8 FT-LB OR 6.6 N-M
 - 3.2 EXTRA HARDWARE MAY BE SUPPLIED
- 4.0 TEST
- 5.0 PACKAGING
 - 5.1 PACKAGING SHALL MEET ANDREW REQUIREMENTS PER DOCUMENT IS-PL-3005
 - 5.2 BAG AND INDIVIDUALLY TAG ALL HARDWARE AND PLACE IN SHIPPING BOX WITH BRACKETS FOR CUSTOMER INSTALLATION.
 - 5.3 THIS PRINTED DOCUMENT TO BE PLACED INSIDE SHIPPING BOX FOR CUSTOMER INSTALLATION

REVISIONS			
REV.	DESCRIPTION	DATE	APPROVED
A	INITIAL RELEASE	NSUN 13SEP23	RW1043 40178739CMO
B	ADDED CONFIGURATION E11; UPDATED THE DRAWINGS OF SHEET1 AND ADDED SHEET 2 & 11	YC1059 31MAY24	LX1002 40196384CMO
C	ADDED EQUIPMENT INSTALLATION CONFIGURATION LIST OF THE IP20 IN SHEET 3; UPDATED VIEWS FOR MTM1160-1141-CR (ITEM 3) CHANGES.	YC1059 15AUG24	LX1002 40203410CMO
D	ADDED MTM1193-1681-00 (ITEM 22); THE INSTALL BRACKET OF 4490 AND 4890 MTM1193-1681-00 WAS MTM1160-1141-CR, UPDATED RELATED VIEWS	YC1059 11OCT24	LX1002 40205276CMO
E	460143456 (ITEM 9) QTY 14 WAS 12; 100117-4 (ITEM 10) QTY 12 WAS 10; MTC9415 (ITEM 17), MTC9418 (ITEM 18) & MTC9419 (ITEM 19) QTY 8 WAS 4; ADDED MTM1221-4009-BR (ITEM 23); SHEET2 & 3: ADDED CONFIGURATION E13, E14 & E15; SHEET4: ADDED EQUIPMENT INSTALLATION OF 4471 & 4461; ADDED SHEET 19, 20 & 21	MS1288 28OCT25	WQ1001 50105522AMO

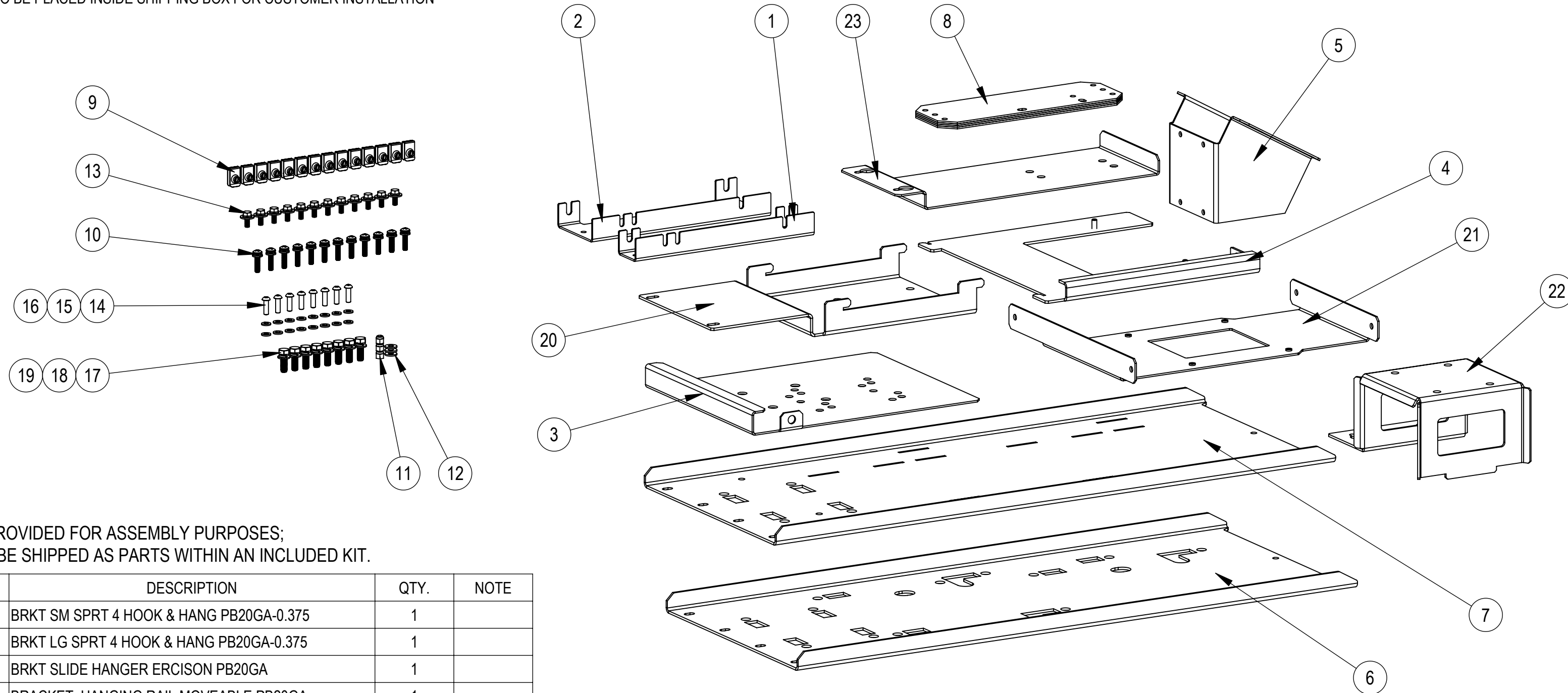

COMPONENT PART NUMBERS PROVIDED FOR ASSEMBLY PURPOSES;
INDIVIDUAL COMPONENTS MAY BE SHIPPED AS PARTS WITHIN AN INCLUDED KIT.

ITEM NO.	PART NUMBER	DESCRIPTION	QTY.	NOTE
1	MTM1193-1111-BR	BRKT SM SPRT 4 HOOK & HANG PB20GA-0.375	1	
2	MTM1193-1112-BR	BRKT LG SPRT 4 HOOK & HANG PB20GA-0.375	1	
3	MTM1160-1141-BR	BRKT SLIDE HANGER ERCISON PB20GA	1	
4	MTM1160-1162-BR	BRACKET, HANGING RAIL MOVEABLE PB20GA	1	
5	MTM1160-1167-BR	BRKT DIPLEX MNTG TOP/ANGLE PB20GA	1	
6	MTM1160-1168-BR	BRKT MAIN PLATE RADIOS REAR PB20GA	1	
7	MTM1160-1169-BR	BRKT MAIN HK & HANG REAR PLT PB20GA	1	
8	MTM1028-661-BR	BRACKET, ERC2203 RADIO	4	
9	460143456	CLIP NUT, M6, 316 SST	14	5.2
10	100117-4	FA,SEMS,PH,XRES,M6X25,SST,PASS	12	5.2
11	SNYL02	1/4" SS NYLOCK HEX NUT	3	5.2
12	SWF-02	FLAT WASHER, 1/4" SS	3	5.2
13	460155492	SEMS, HCS M6 X 16MM WITH CAPTIVE WASHERS	12	5.2
14	100560-66	SCR,BUTTN HD,HEXSOCK,M6X20,SST,PASS	8	5.2
15	100522-25	WSHR,LK,SPLT, M6,SST, PASS	8	5.2
16	100521-25	WSHR,FLAT,M6,6.4X12X1.6,SST,PASS	8	5.2
17	MTC9415	M8 X 25mm HEX BOLT SS	8	5.2
18	MTC9418	M8 LOCK WASHER SS	8	5.2
19	MTC9419	M8 FLAT WASHER SS	8	5.2
20	MTM1209-1000-BR	BRKT MOUNT RU4467	1	
21	MTM1209-2000-BR	BRKT MOUNT AC08	1	
22	MTM1193-1681-00	BRKT MOUNT RU4890 AND 4490	1	
23	MTM1221-4009-BR	MOUNTING BRACKET, ERC E-4461/4471	1	
9000	MTM1193-1101-AMK-E	KIT ERICSSON INSTALL INTO PB20GA-0.375	1	5.3

DENSITY	25.84	lbs/in ³
MASS	3888.00	lbs
VOLUME	1944.00	in ³
SURFACE AREA	18.00[457.2]	in ²
HEIGHT	6.00[152.4]	
LENGTH	36.00[914.4]	
WIDTH	18.00[457.2]	

Confidential



ANDREW® an Amphenol company

TOLERANCES		SAP MATERIAL MASTER	
1 PLACE .X[X] ± N/A	3 PLACE .XXX[X] ± N/A	MTM1193-1101-AMK-E	
2 PLACE .XX[X] ± N/A	ANGLES ± N/A°		
FINISH		MATERIAL	
UNLESS OTHERWISE SPECIFIED DIMENSIONS ARE IN INCHES INTERPRET PER ANSI Y 14.5M-1994	NAME	DATE	TITLE
	CE NSUN	13SEP23	KIT ERICSSON INSTALL INTO PB20GA-0.375
	RW MS1288	11/12/2025	
	AD JX1002	11/13/2025	
	RE DM1121	11/13/2025	
ECN 50105522AMO			
SCALE	DOCUMENT NO.	MTM1193-1101-AMK-E	
1:8			
SIZE	Auth Group	INSL	MODEL
C			
VERSION		STATUS	REVISION
02		RE	C
DRAWING		VERSION	STATUS
		04	RE
REVISION		REVISION	REVISION
			E
SHEET			1 OF 21

ERICSSON EQUIPMENT INSTALLATION CONFIGURATION LIST

CONFIGURATION	SHEET NO.	EQUIP.1	QTY	EQUIP.1	QTY	EQUIP.3	QTY
E2	7	8843	1			QUAD DIPLEXER SDX1926Q-43	1
E3	8	4449	1				
E4	9	8863	1			QUAD DIPLEXER SDX1926Q-43	1
E5	10	4415	1				
E6	11	4426	1				
E7	12	4478	1				
E8	13	2203	4			QUAD DIPLEXER SDX1926Q-43	1
E11	16	4467	1			AC08	1
E13	19	4471	1			QUAD DIPLEXER SDX1926Q-43	1
E14	20	4461	1			QUAD DIPLEXER SDX1926Q-43	1
E15	21	4471	1	4461	1	QUAD DIPLEXER SDX1926Q-43	1

ESTABLISH ERICSSON CONFIGURATION FROM ABOVE TABLE TO INSTALL DESIRED ERICSSON RADIOS IN THE PB20GA AND OPTIONAL D-MODULE
 SEE SHEET 4 & 5 FOR DETAILED SECURING OF RADIOS & DIPLEXERS TO BRACKETS.
 SEE SPECIFIC SHEET NUMBER FOR FURTHER INSTALLATION DETAILS.

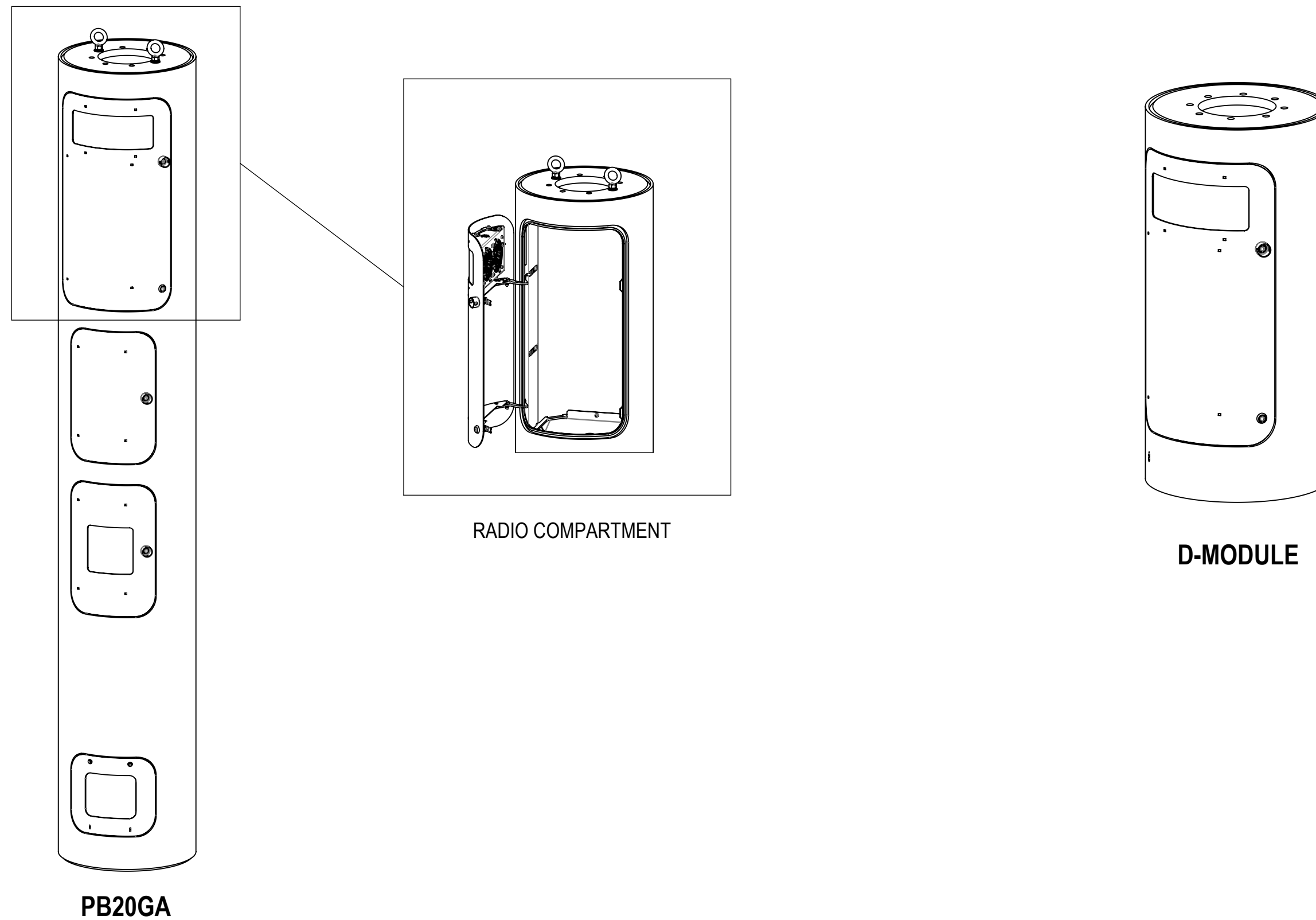

ANDREW an Amphenol company

TITLE
KIT ERICSSON INSTALL INTO PB20GA-0.375

SIZE C	SCALE 1:16	DOCUMENT NO. MTM1193-1101-AMK-E
DRAWING		SHEET
VERSION 04	STATUS RE	REVISION E
		2 OF 21

Confidential

ERICSSON EQUIPMENT INSTALLATION CONFIGURATION LIST

CONFIGURATION	SHEET NO.	EQUIP.1	QTY	EQUIP.1	QTY	EQUIP.2	QTY
E1	6	4455	1				
E2	7	8843	1			QUAD DIPLEXER SDX1926Q-43	1
E3	8	4449	1				
E4	9	8863	1			QUAD DIPLEXER SDX1926Q-43	1
E5	10	4415	1				
E6	11	4426	1				
E7	12	4478	1				
E8	13	2203	4			QUAD DIPLEXER SDX1926Q-43	1
E9	14	4408	4			QUAD DIPLEXER SDX1926Q-43	1
E10	15	4490	1				
E11	17	4467	1				1
E12	18	4890	1				
E13	19	4471	1			QUAD DIPLEXER SDX1926Q-43	1
E14	20	4461	1			QUAD DIPLEXER SDX1926Q-43	1
E15	21	4471	1	4461	1	QUAD DIPLEXER SDX1926Q-43	1

ESTABLISH ERICSSON CONFIGURATION FROM ABOVE TABLE TO INSTALL DESIRED ERICSSON RADIOS IN THE IP20
 SEE SHEET 4 & 5 FOR DETAILED SECURING OF RADIOS & DIPLEXERS TO BRACKETS.
 SEE SPECIFIC SHEET NUMBER FOR FURTHER INSTALLATION DETAILS.

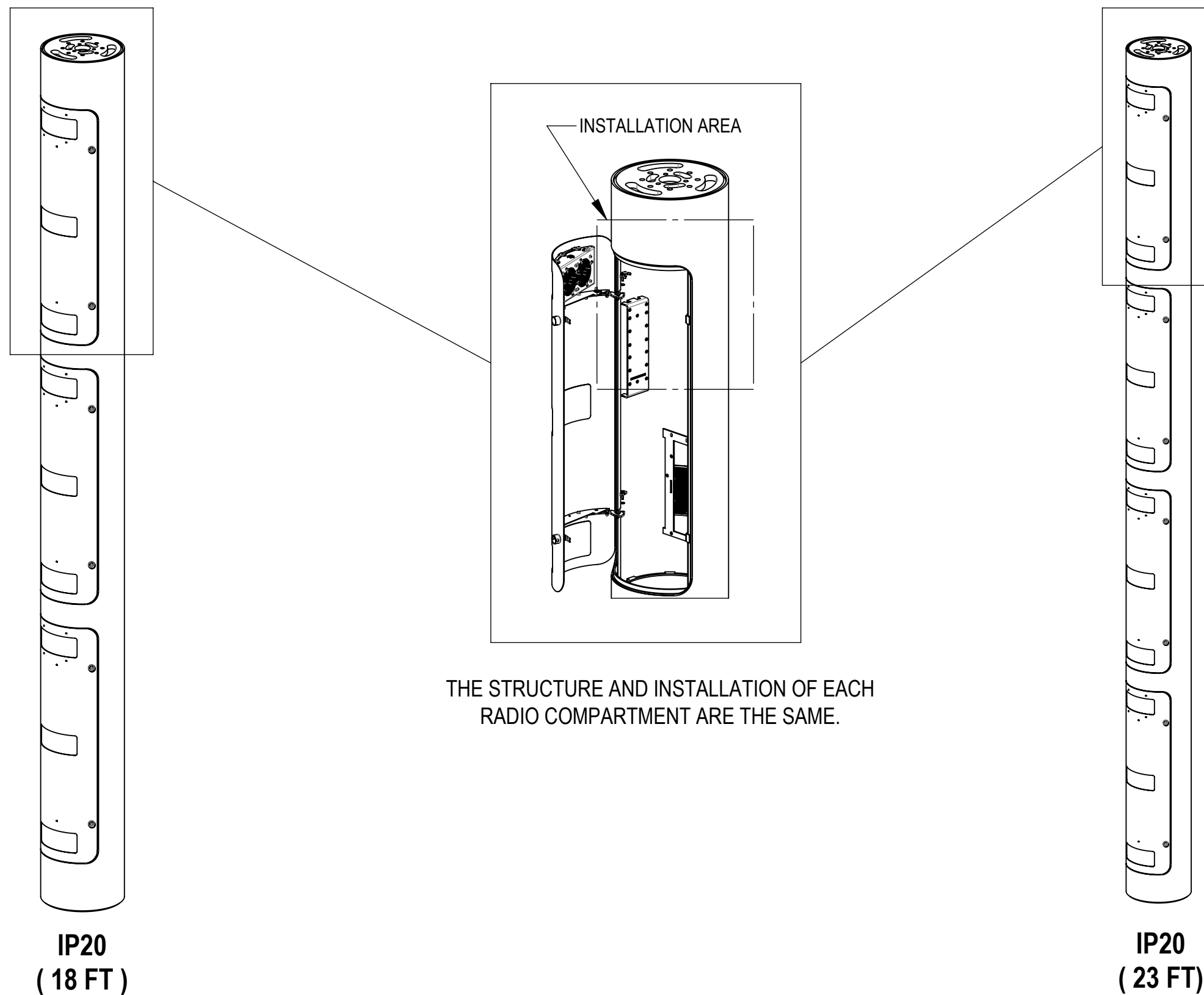

ANDREW® an Amphenol company

TITLE
KIT ERICSSON INSTALL INTO PB20GA-0.375

SIZE C	SCALE 1:16	DOCUMENT NO. MTM1193-1101-AMK-E
DRAWING		SHEET
VERSION 04	STATUS RE	REVISION E

3 OF 21

Confidential

EQUIPMENT MOUNTING INSTALLATION

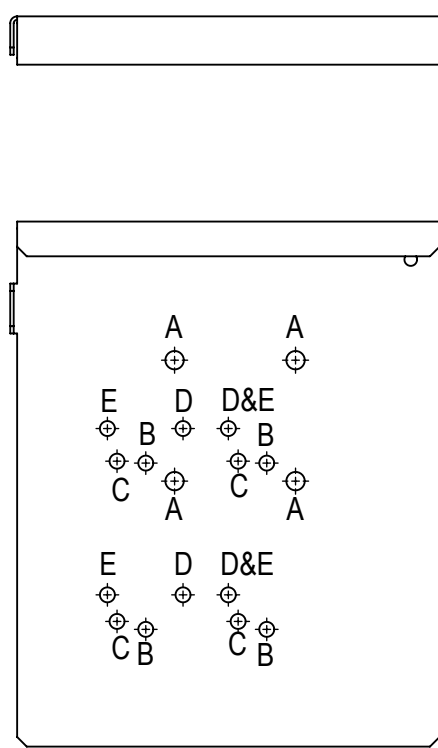

RADIO INSTALLATION MTM1160-1141-BR

- "A": 4455
- "B": 8843 / 4449
- "C": 8863
- "D": 4415 / 4426 / 4478 / 4471 / 4461
- "E": 4467

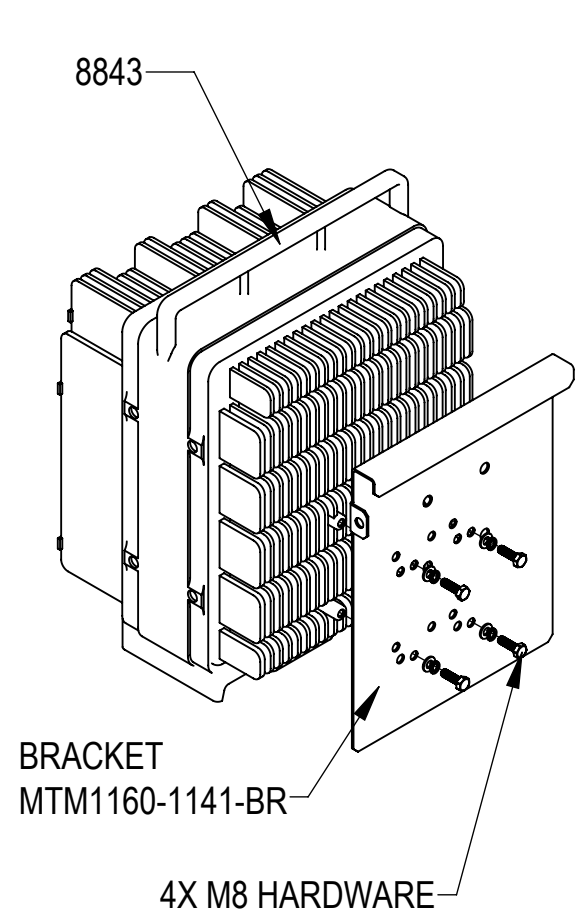

8843:
INSTALL 8843 TO THE MOUNTING BRACKET MTM1160-1141-BR USING 4 SETS OF M8 HEX BOLTS, LOCK WASHERS AND FLAT WASHERS AS SHOWN

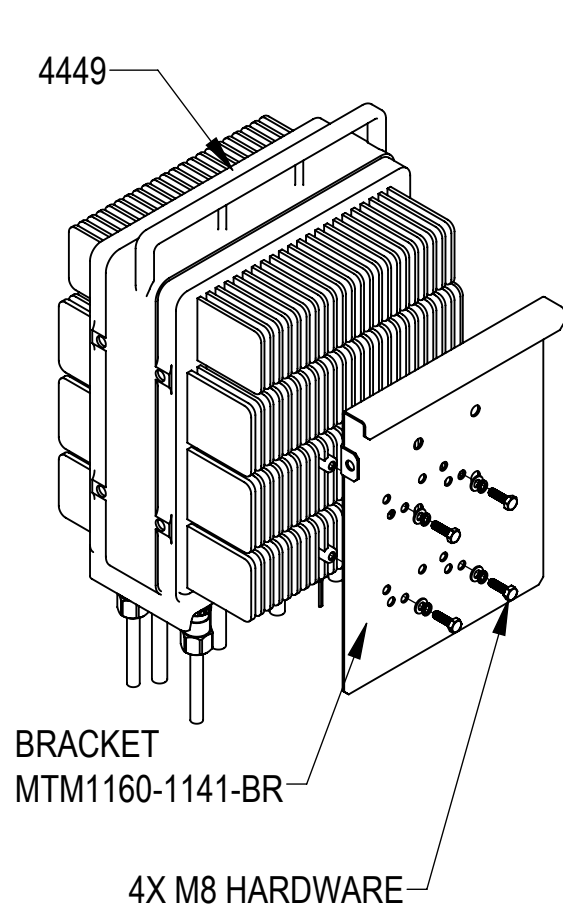

4449:
INSTALL 4449 TO THE MOUNTING BRACKET MTM1160-1141-BR USING 4 SETS OF M8 HEX BOLTS, LOCK WASHERS AND FLAT WASHERS AS SHOWN

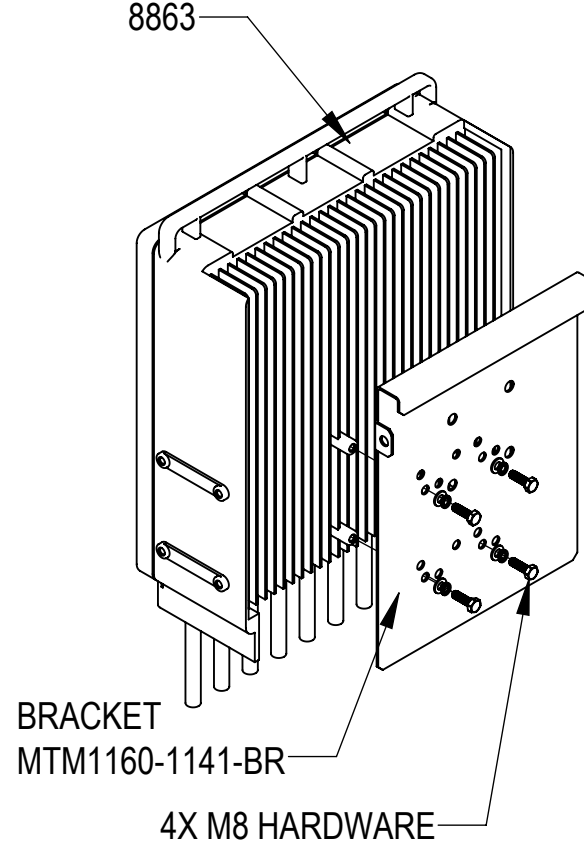

8863:
INSTALL 8863 TO THE MOUNTING BRACKET MTM1160-1141-BR USING 4 SETS OF M8 HEX BOLTS, LOCK WASHERS AND FLAT WASHERS AS SHOWN

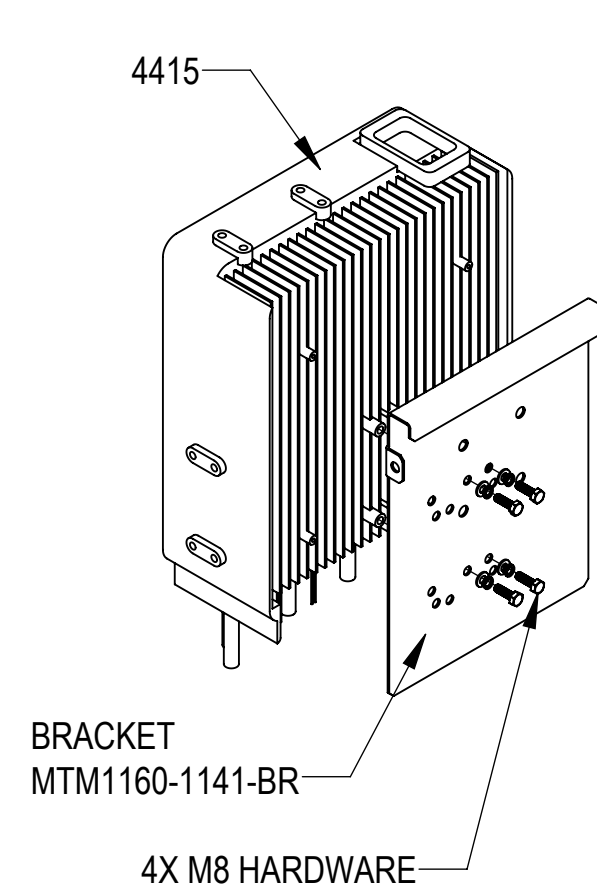

4415:
INSTALL 4415 TO THE MOUNTING BRACKET MTM1160-1141-BR USING 4 SETS OF M8 HEX BOLTS, LOCK WASHERS AND FLAT WASHERS AS SHOWN

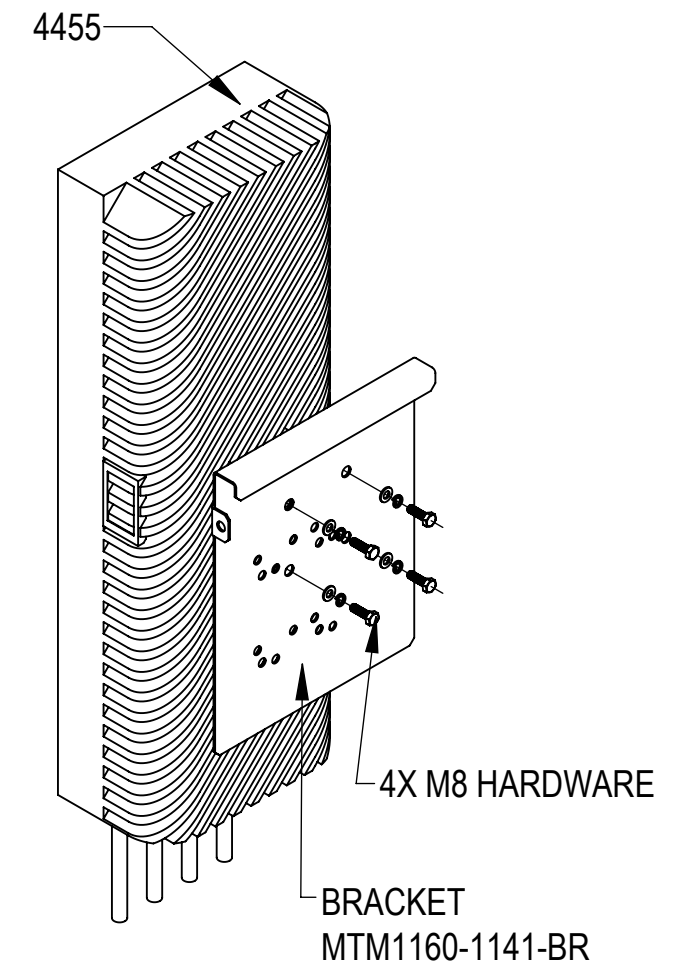

4455:
INSTALL 4455 TO THE MOUNTING BRACKET MTM1160-1141-BR USING 4 SETS OF M8 HEX BOLTS, LOCK WASHERS AND FLAT WASHERS AS SHOWN

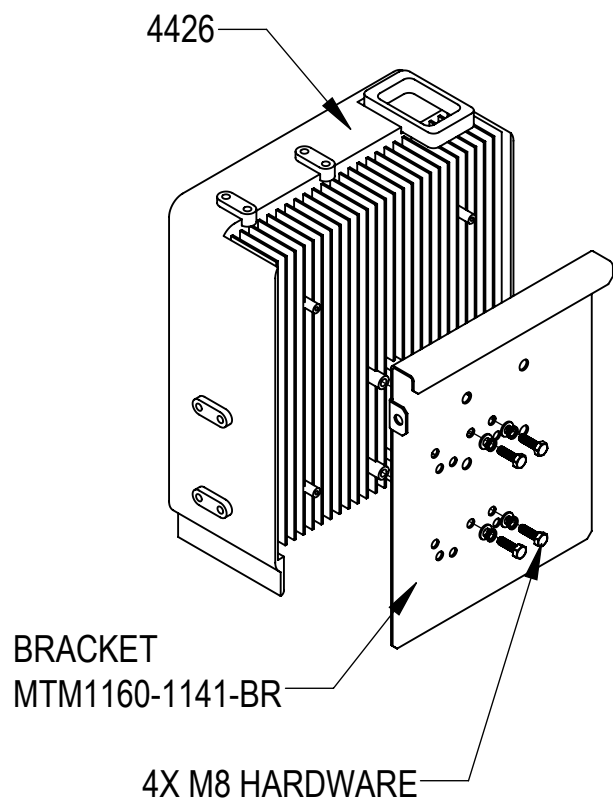

4426:
INSTALL 4426 TO THE MOUNTING BRACKET MTM1160-1141-BR USING 4 SETS OF M8 HEX BOLTS, LOCK WASHERS AND FLAT WASHERS AS SHOWN

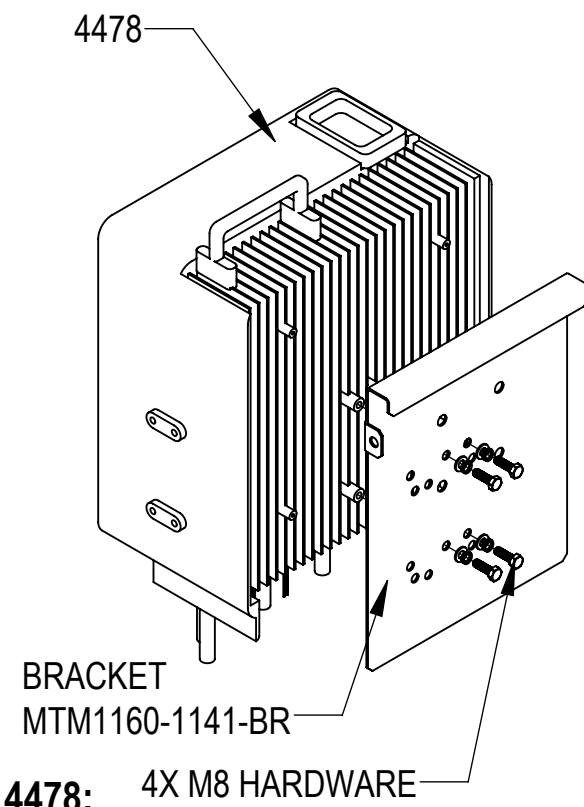

4478:
INSTALL 4478 TO THE MOUNTING BRACKET MTM1160-1141-BR USING 4 SETS OF M8 HEX BOLTS, LOCK WASHERS AND FLAT WASHERS AS SHOWN

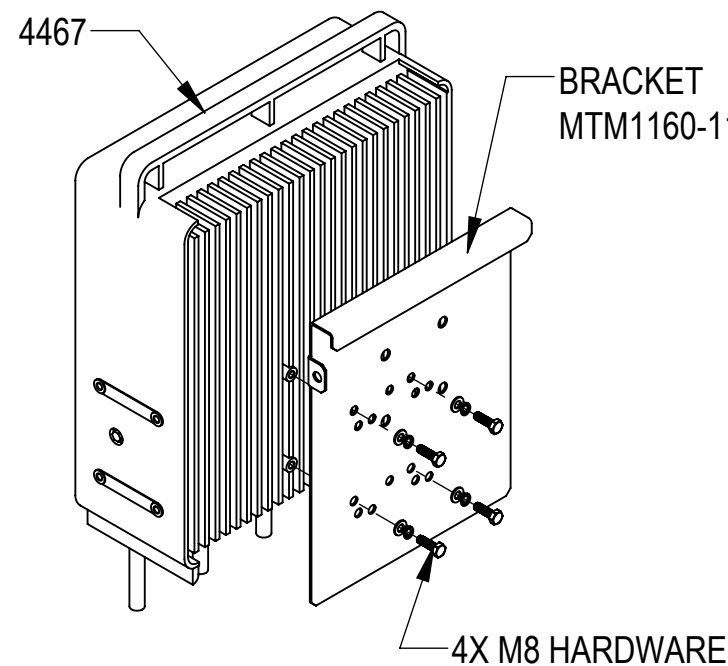

4467 (IP20):
INSTALL 4467 TO THE MOUNTING BRACKET MTM1160-1141-BR USING 4 SETS OF M8 HEX BOLTS, LOCK WASHERS AND FLAT WASHERS AS SHOWN

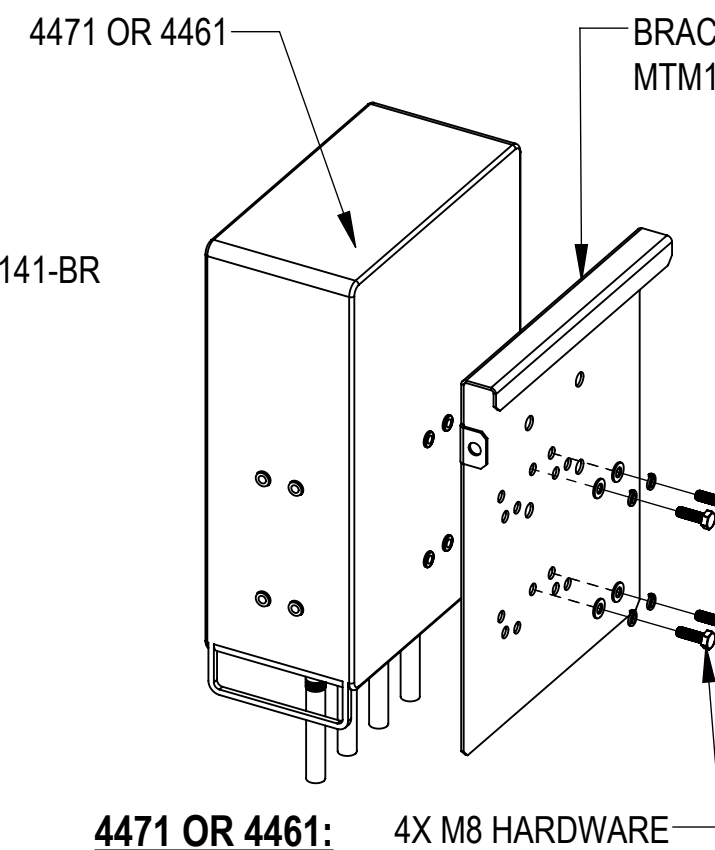

4471 OR 4461:
INSTALL 4471 OR 4461 TO THE MOUNTING BRACKET MTM1160-1141-BR USING 4 SETS OF M8 HEX BOLTS, LOCK WASHERS AND FLAT WASHERS AS SHOWN

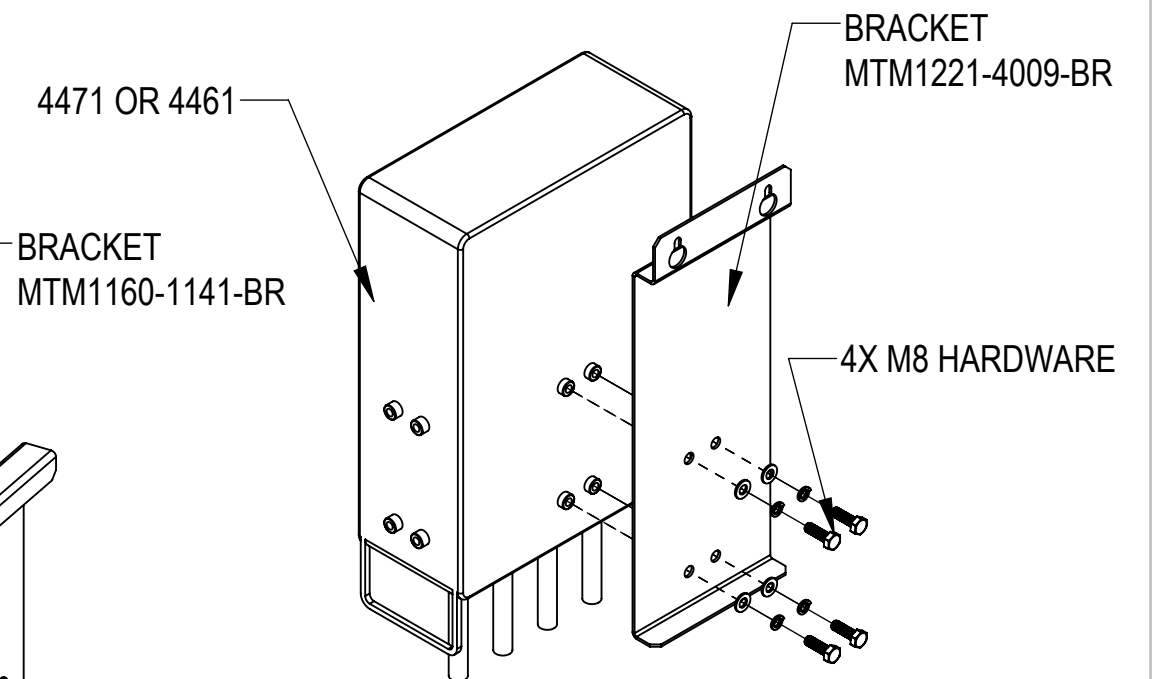

4471 OR 4461:
INSTALL 4471 OR 4461 TO THE MOUNTING BRACKET MTM1221-4009-BR USING 4 SETS OF M8 HEX BOLTS, LOCK WASHERS AND FLAT WASHERS AS SHOWN

TORQUE ALL TO SPEC

ANDREW an Amphenol company

TITLE
KIT ERICSSON INSTALL INTO PB20GA-0.375

SIZE C	SCALE 1:10	DOCUMENT NO. MTM1193-1101-AMK-E
DRAWING		SHEET
VERSION 04	STATUS RE	REVISION E
		4 OF 21

Confidential

EQUIPMENT MOUNTING INSTALLATION

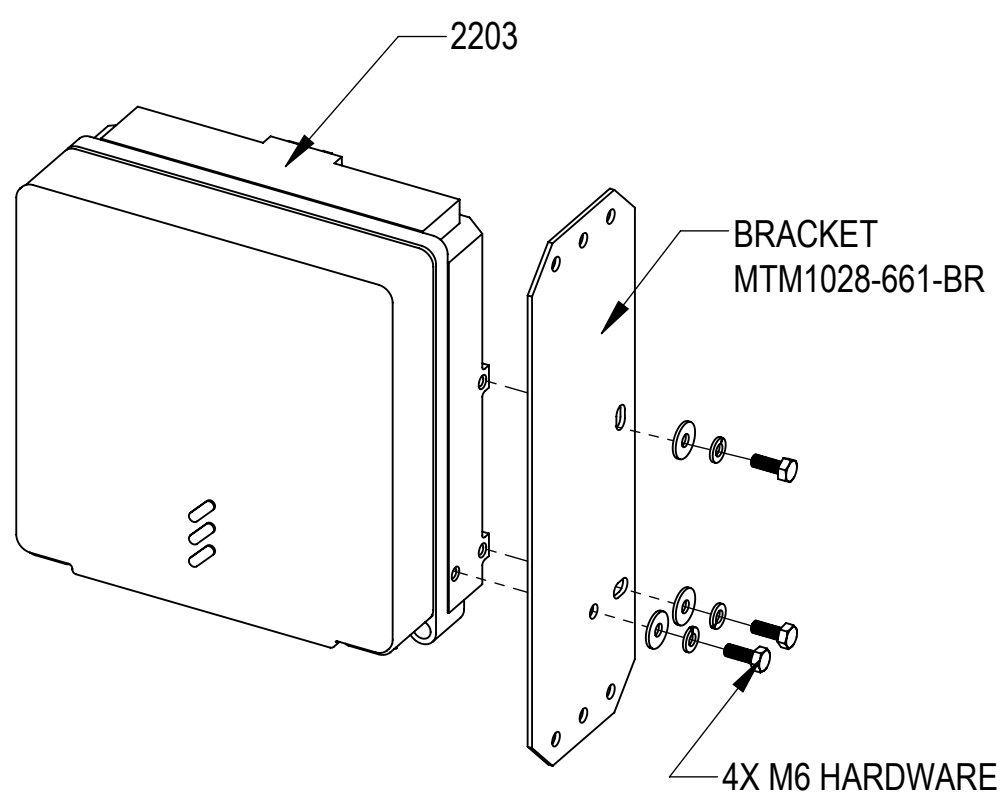

2203:

INSTALL THE ERC 2203 TO THE MOUNTING BRACKET MTM1028-661-BR USING 4 SETS OF M6 HEX BOLTS, LOCK WASHERS AND FLAT WASHERS AS SHOWN

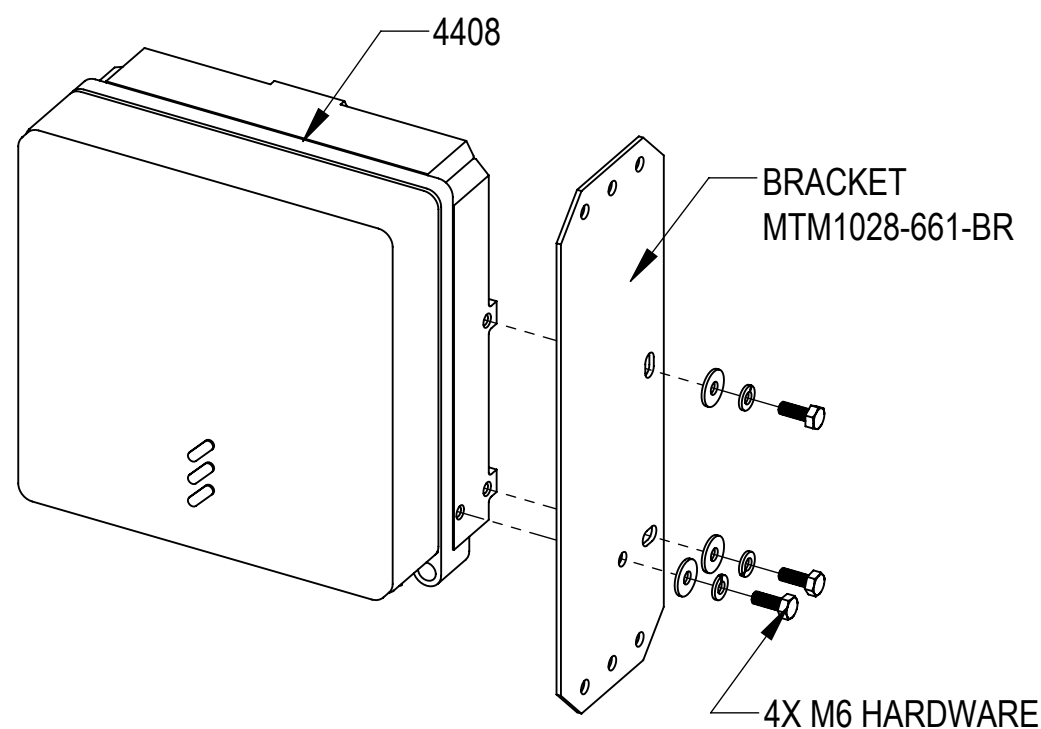

4408:

INSTALL THE ERC 4408 TO THE MOUNTING BRACKET MTM1028-661-BR USING 4 SETS OF M6 HEX BOLTS, LOCK WASHERS AND FLAT WASHERS AS SHOWN

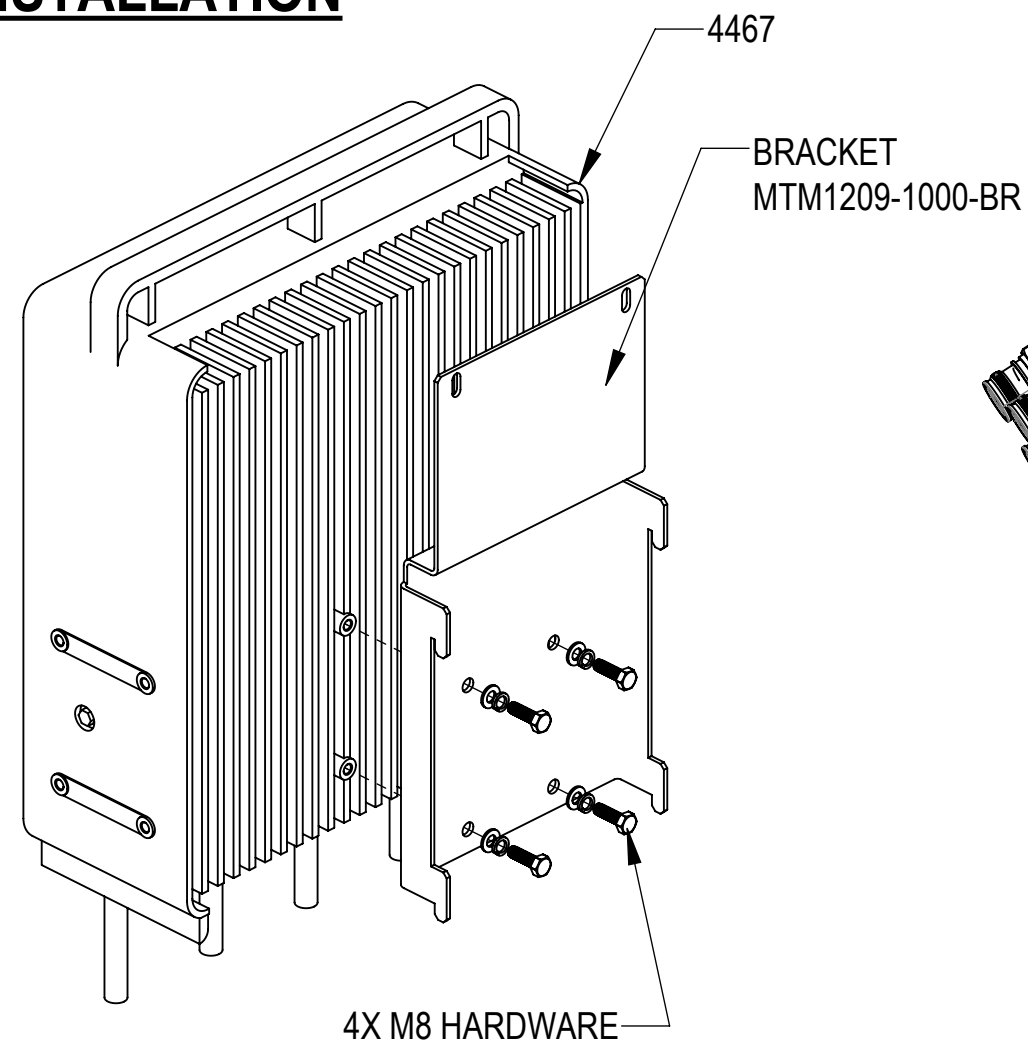

4467 (PB20 AND D-MODULE):

INSTALL THE ERC 4467 TO THE MOUNTING BRACKET MTM1209-1000-BR USING 4 SETS OF M8 HEX BOLTS, LOCK WASHERS AND FLAT WASHERS AS SHOWN

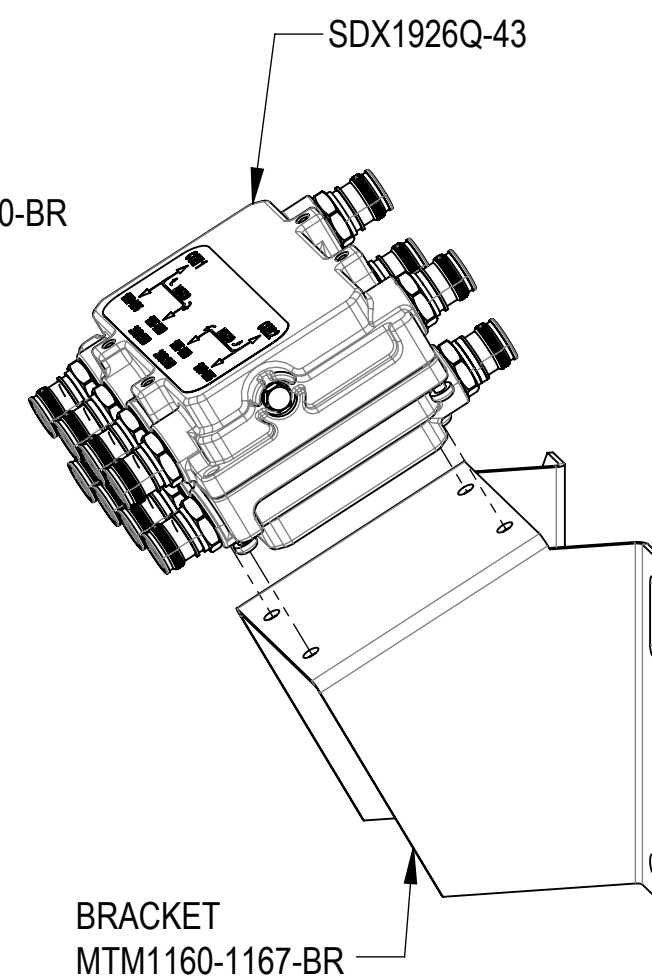

SDX1926Q-43:

INSTALL THE QUAD DIPLEXER SDX1926Q-43 TO THE MOUNTING BRACKET MTM1160-1167-BR USING 4 SETS OF M5 CAPTIVE SEM SCREWS PROVIDED WITH THE SDX1926Q-43

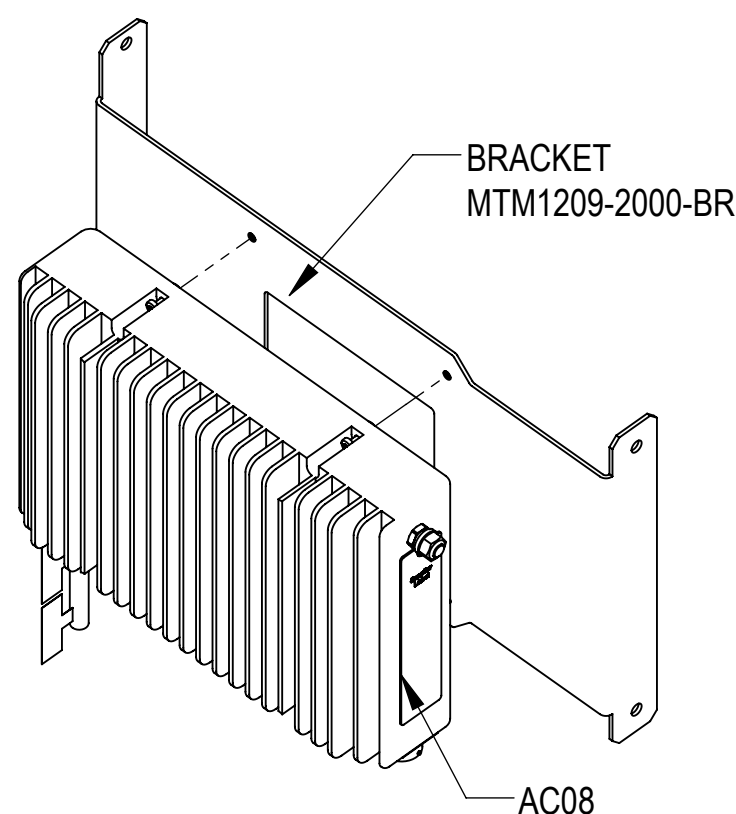

AC08:

INSTALL THE PSU AC08 TO THE MOUNTING BRACKET MTM1209-2000-BR USING 4 SETS OF M4 CAPTIVE SCREWS AND FLAT WASHER PROVIDED WITH THE PSU AC08

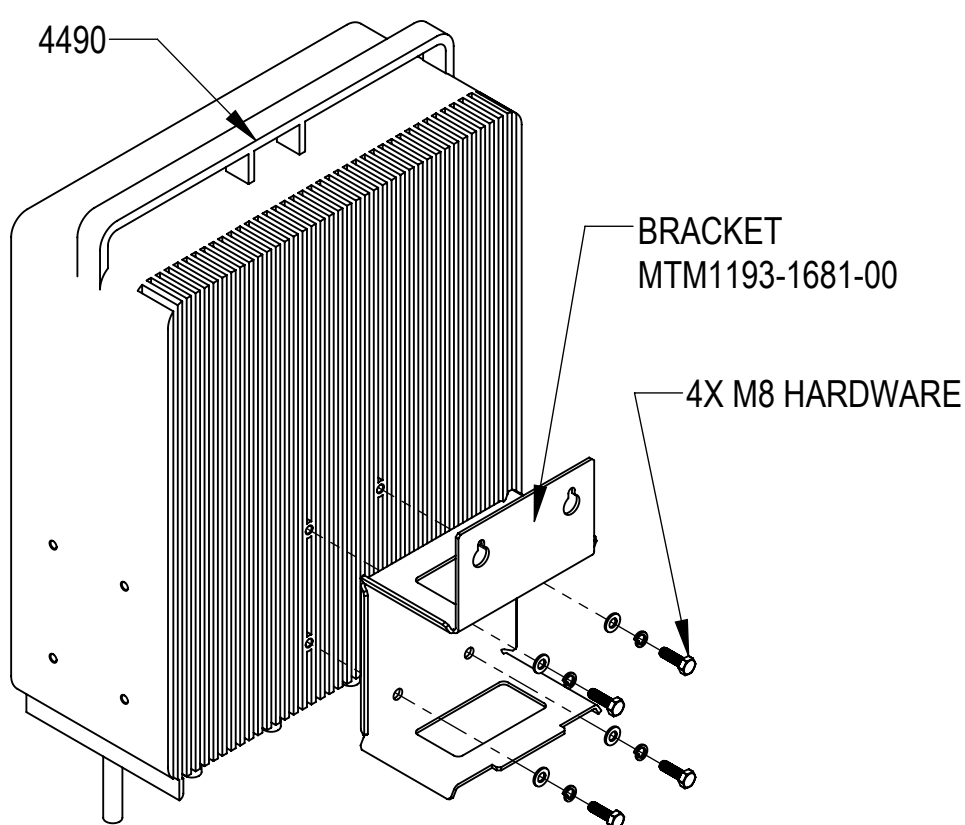

4490 (IP20):

INSTALL THE ERC 4490 TO THE MOUNTING BRACKET MTM1193-1681-00 USING 4 SETS OF M8 HEX BOLTS, LOCK WASHERS AND FLAT WASHERS AS SHOWN

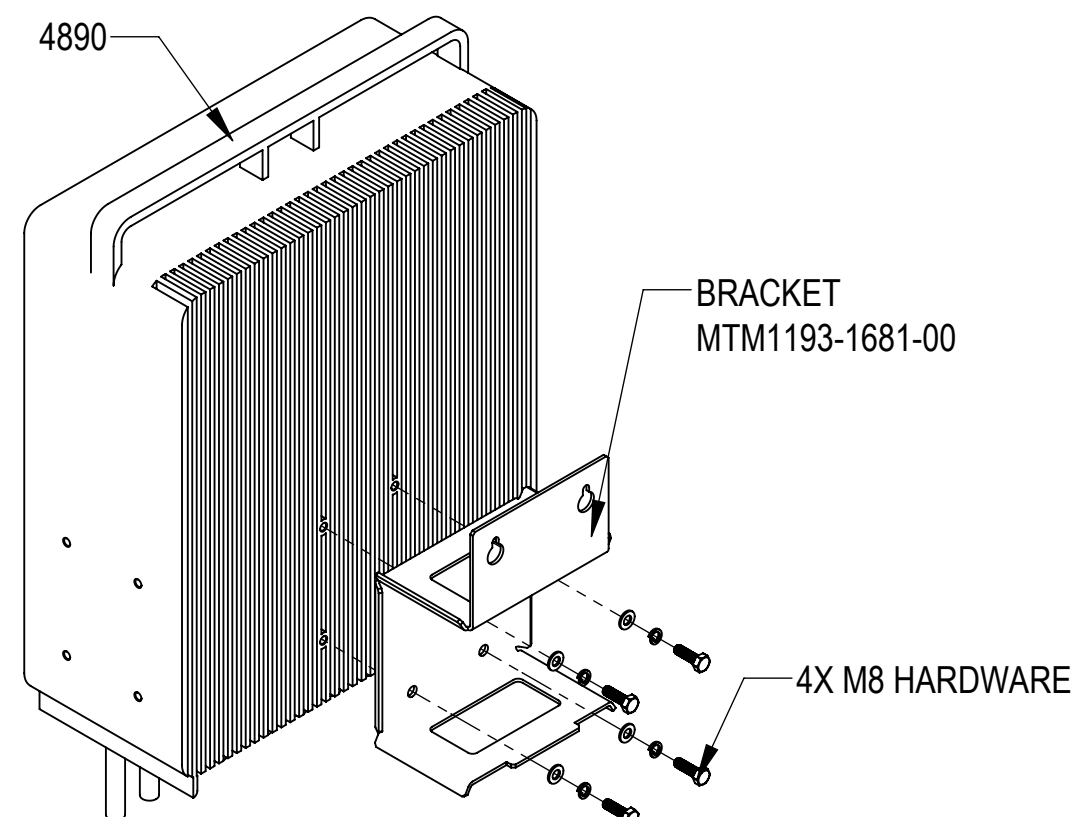

4890 (IP20):

INSTALL THE ERC 4890 TO THE MOUNTING BRACKET MTM1193-1681-00 USING 4 SETS OF M8 HEX BOLTS, LOCK WASHERS AND FLAT WASHERS AS SHOWN

TORQUE ALL TO SPEC



TITLE
KIT ERICSSON INSTALL INTO PB20GA-0.375

SIZE C	SCALE 1:10	DOCUMENT NO. MTM1193-1101-AMK-E		
		DRAWING		SHEET 5 OF 21
		VERSION 04	STATUS RE	

Confidential

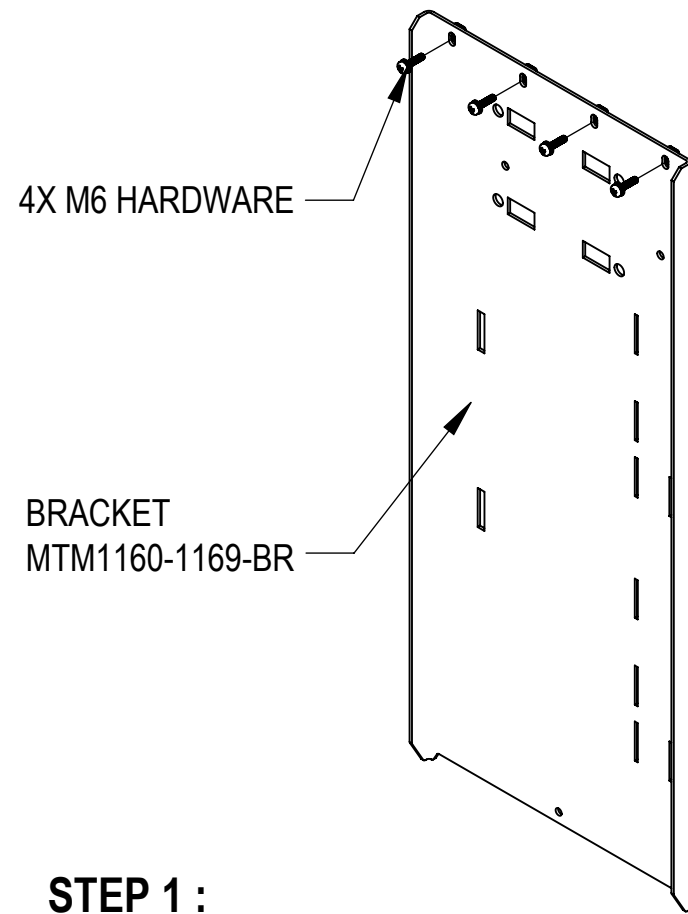
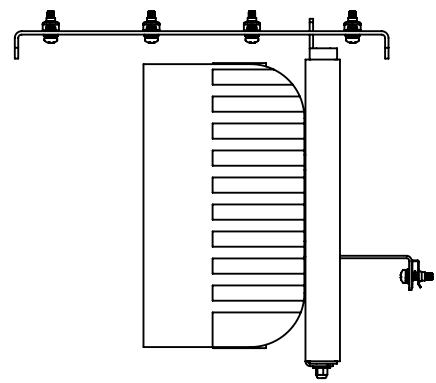

STEP 1 :
MTM1160-1169-BR
 1. INSTALL THE MOUNTING BRACKET MTM1160-1169-BR TO BRACKET OF ASSEMBLY USING 4 SETS OF M6 SEMS SCREWS AND CLIP NUTS

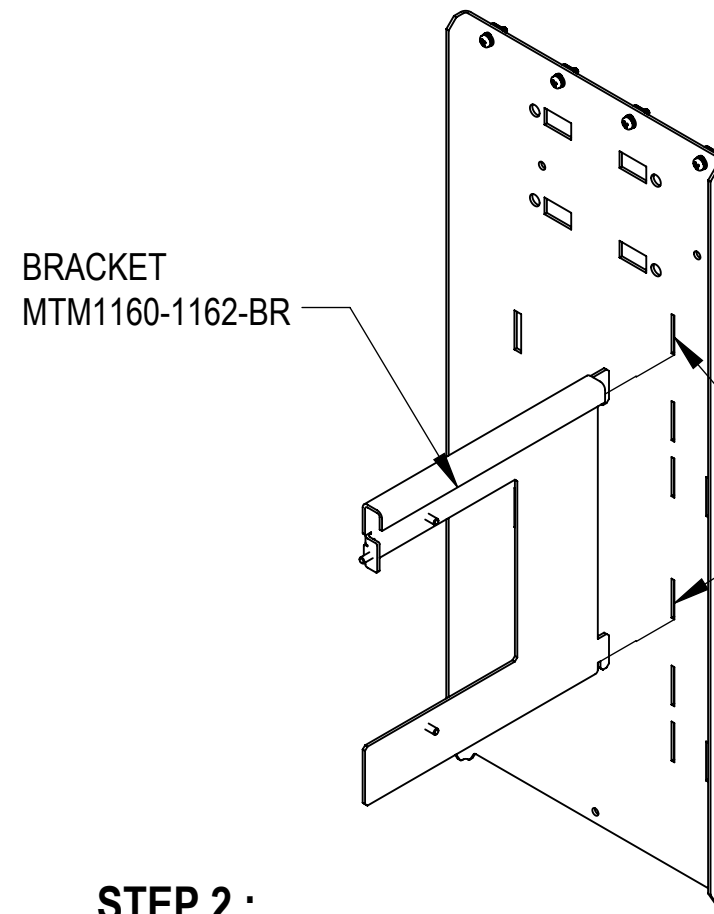

STEP 2 :
MTM1160-1162-BR
 1. HANG THE MOUNTING BRACKET MTM1160-1162-BR TO THE 2 HOLES FROM THE FIRST COLUMN OUTSIDE OF THE MOUNTING BRACKET MTM1160-1169-BR

THE INSTALLATION POSITIONS ARE THE 1ST AND 4TH HOLES FROM THE TOP

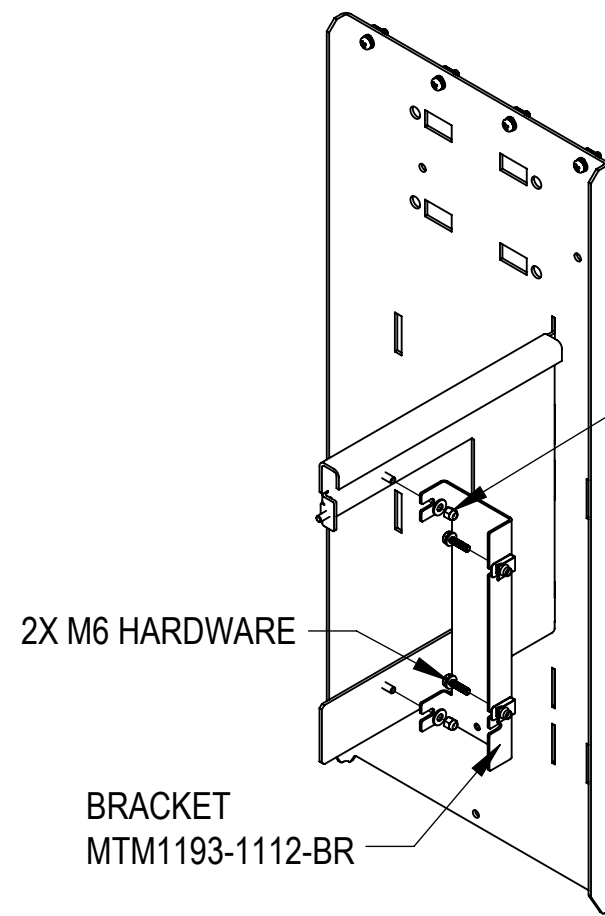
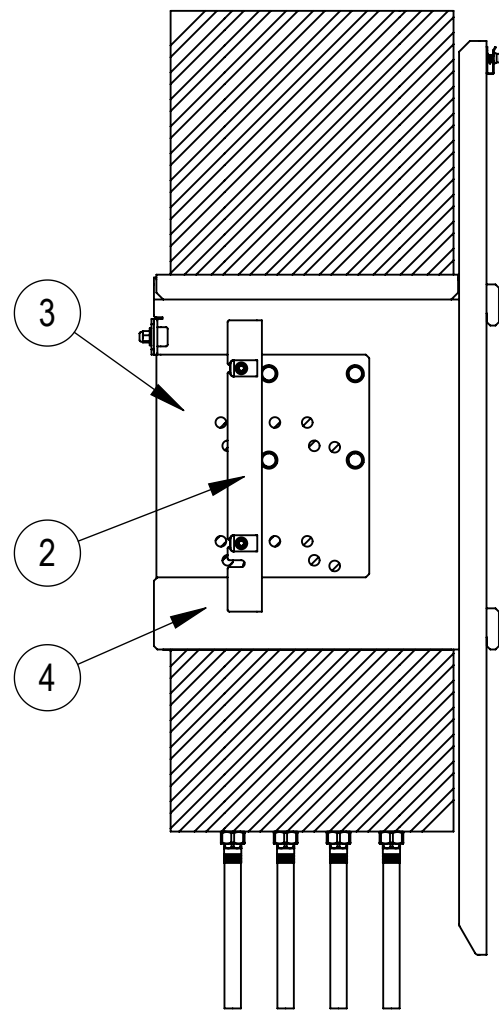
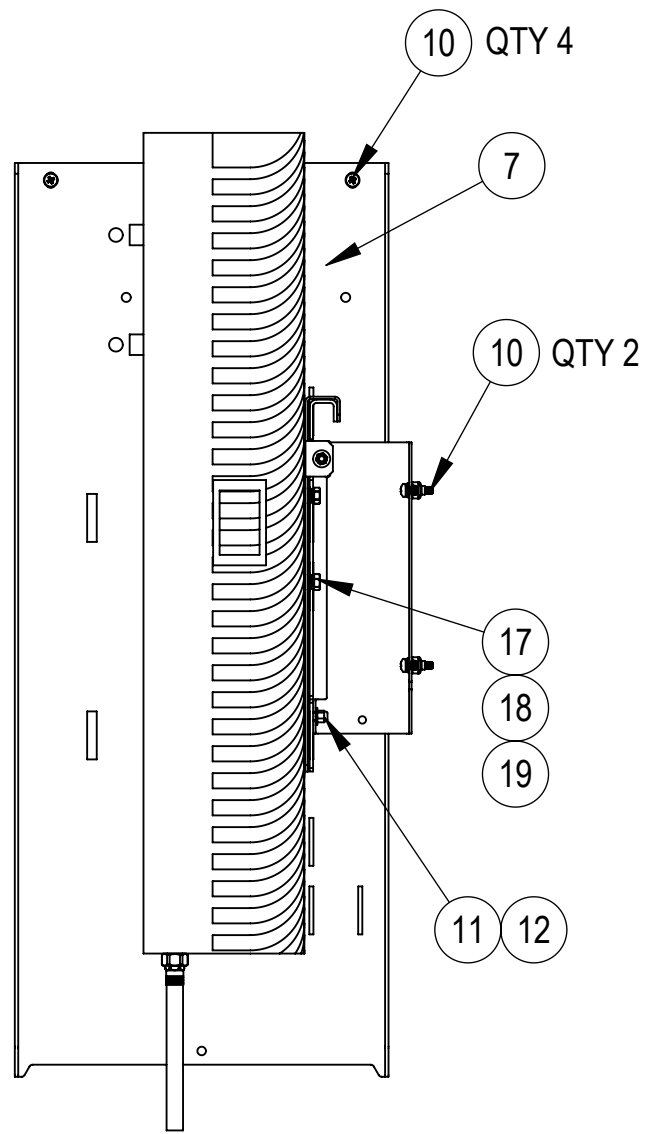

STEP 3 :
MTM1193-1112-BR
 1. INSTALL ONE SIDE OF THE MOUNTING BRACKET MTM1193-1112-BR TO BRACKET OF ASSEMBLY USING 2 SETS OF M6 SEMS SCREWS, CLIP NUTS AND THE OTHER SIDE(AVOIDED SLOT) TO THE MOUNTING BRACKET MTM1160-1162-BR USING 2 SETS OF 1/4\"/>

2X 1/4" NUT AND FLAT WASHER

2X M6 HARDWARE

BRACKET MTM1193-1112-BR

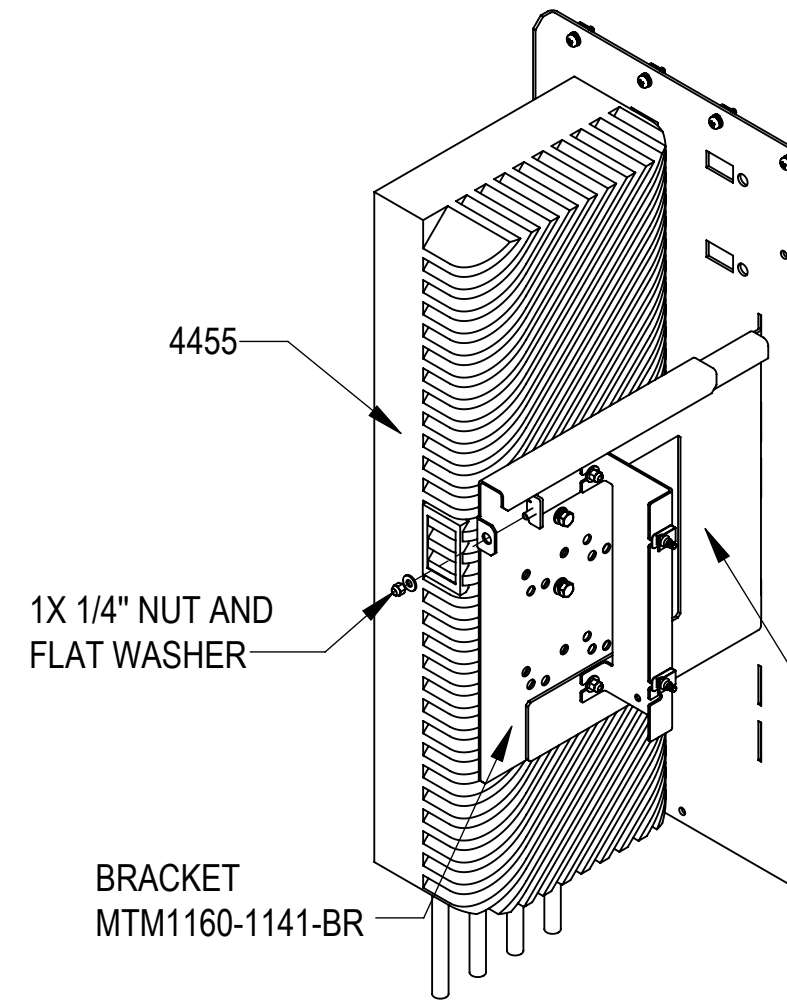

STEP 4 :
MTM1160-1141-BR (4455)
 1. HANG THE MOUNTING BRACKET MTM1160-1141-BR TO THE MOUNTING BRACKET MTM1160-1162-BR AND LOCK THE SIDE USING 1 SET OF 1/4\"/>

1X 1/4" NUT AND FLAT WASHER

BRACKET MTM1160-1141-BR

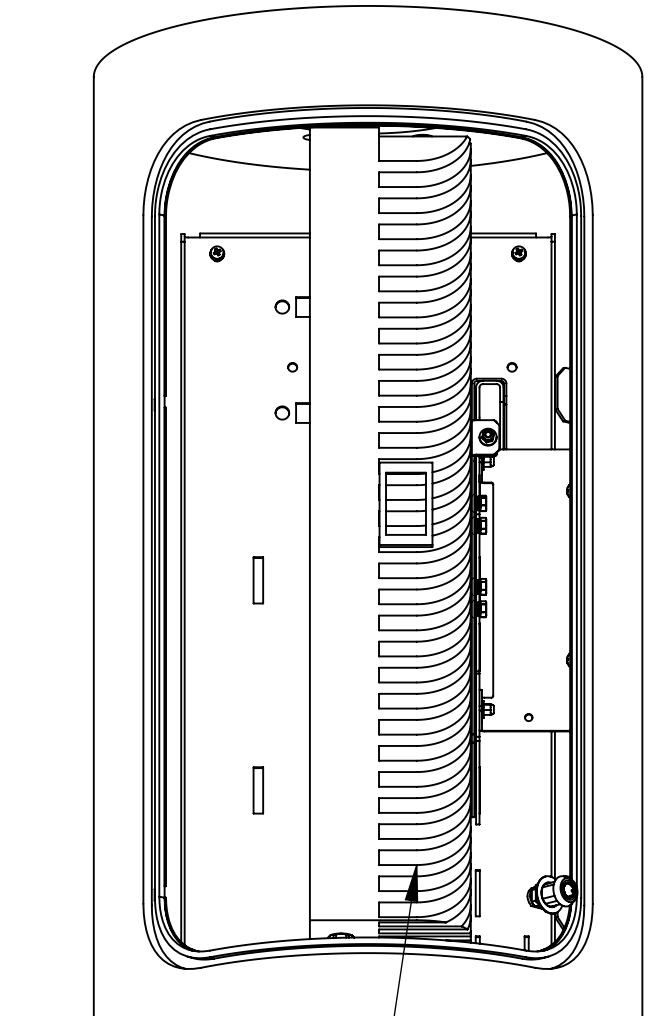

4455

INSTALLED VIEW

BRACKET MTM1160-1162-BR

BOM FOR 4455 INSTALLATION

ITEM NO.	PART NUMBER	DESCRIPTION	QTY.
2	MTM1193-1112-BR	BRKT LG SPRT 4 HOOK & HANG PB20GA-0.375	1
3	MTM1160-1141-BR	BRKT SLIDE HANGER ERCISON PB20GA	1
4	MTM1160-1162-BR	BRACKET, HANGING RAIL MOVEABLE PB20GA	1
7	MTM1160-1169-BR	BRKT MAIN HK & HANG REAR PLT PB20GA	1
10	100117-4	FA,SEMS,PH,XRES,M6X25,SST,PASS	6
11	SNYL02	1/4" SS NYLOCK HEX NUT	3
12	SWF-02	FLAT WASHER, 1/4" SS	3
17	MTC9415	M8 X 25mm HEX BOLT SS	4
18	MTC9418	M8 LOCK WASHER SS	4
19	MTC9419	M8 FLAT WASHER SS	4

E1 (IP20) : 4455 INSTALLATION

EQUIPMENT INSTALLATION SEE SHEET 4
 TORQUE ALL TO SPEC



TITLE
 KIT ERICSSON INSTALL INTO PB20GA-0.375

SIZE **C** SCALE **1:10** DOCUMENT NO.
 MTM1193-1101-AMK-E

DRAWING			SHEET 6 OF 21
VERSION	STATUS	REVISION	
04	RE	E	

Confidential

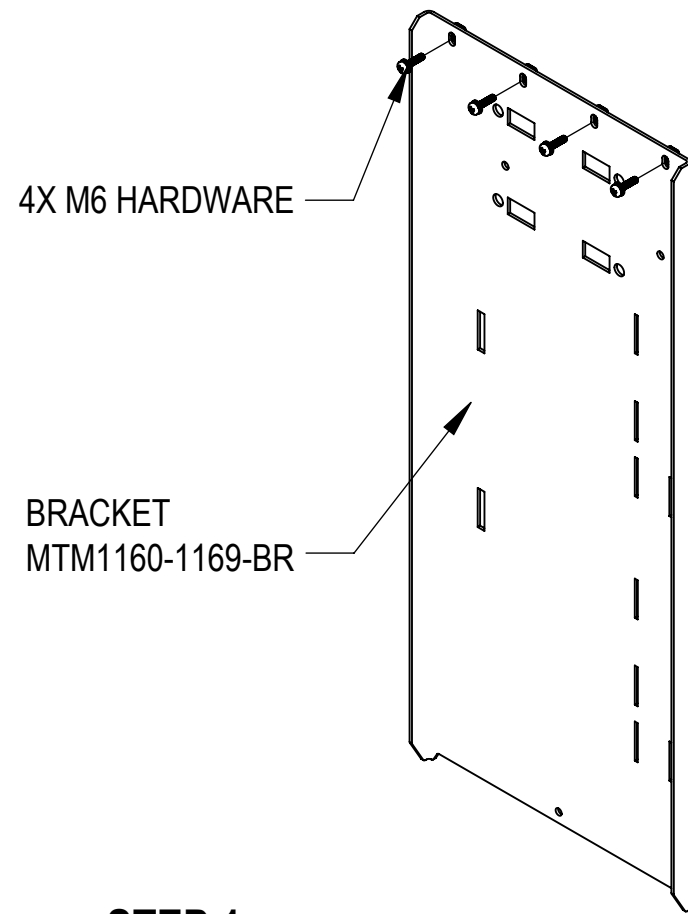
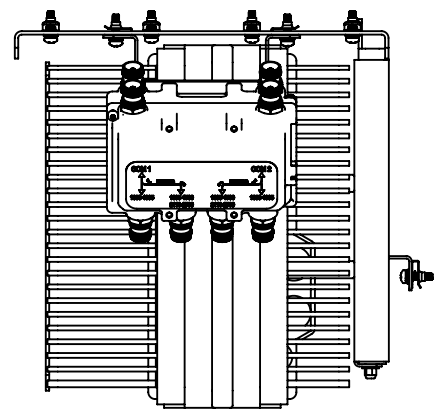

**STEP 1 :
MTM1160-1169-BR**

1. INSTALL THE MOUNTING BRACKET MTM1160-1169-BR TO BRACKET OF ASSEMBLY USING 4 SETS OF M6 SEMS SCREWS AND CLIP NUTS

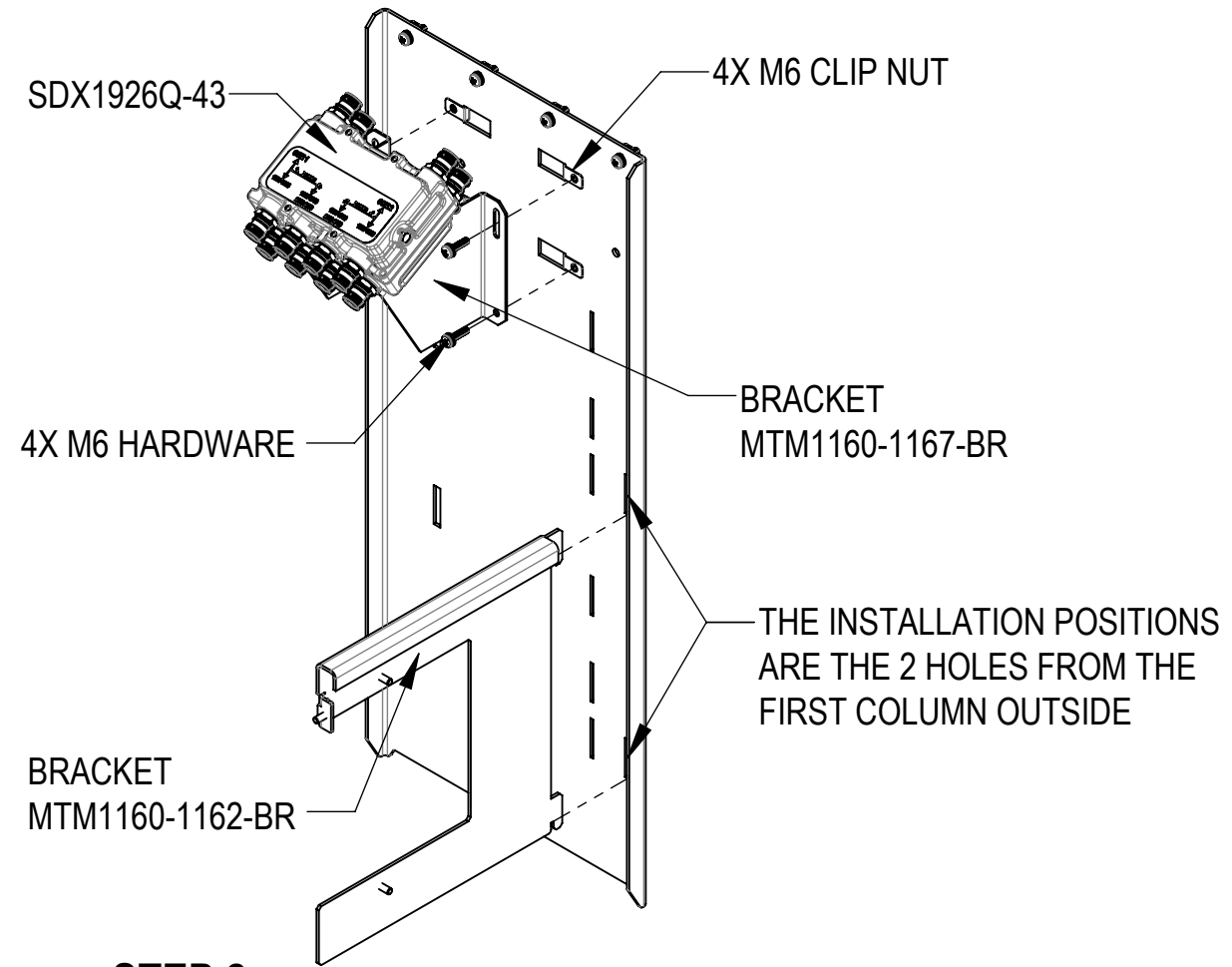

**STEP 2 :
MTM1160-1167-BR (SDX1926Q-43) + MTM1160-1162-BR**

1. INSTALL M6 CLIP NUTS AS SHOWN
2. INSTALL THE MOUNTING BRACKET MTM1160-1167-BR TO THE MOUNTING BRACKET MTM1160-1169-BR USING 4 SETS OF SEMS SCREWS.
3. HANG THE MOUNTING BRACKET MTM1160-1162-BR TO THE 2 HOLES FROM THE FIRST COLUMN OUTSIDE OF THE MOUNTING BRACKET MTM1160-1169-BR

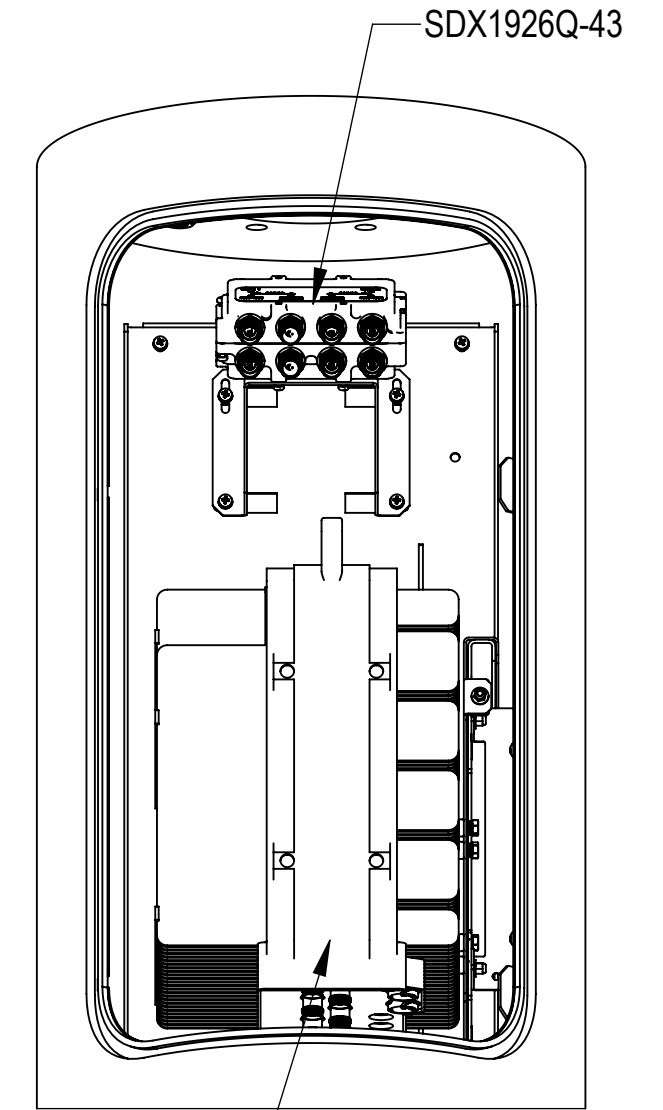

INSTALLED VIEW

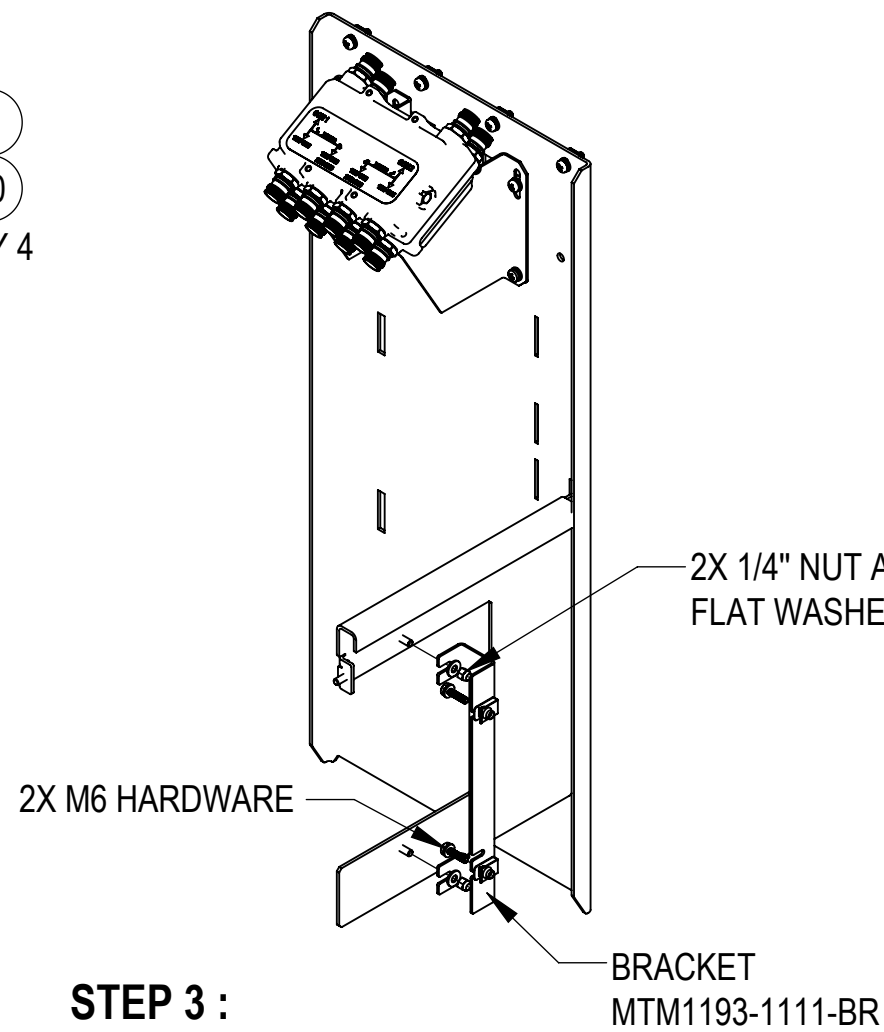
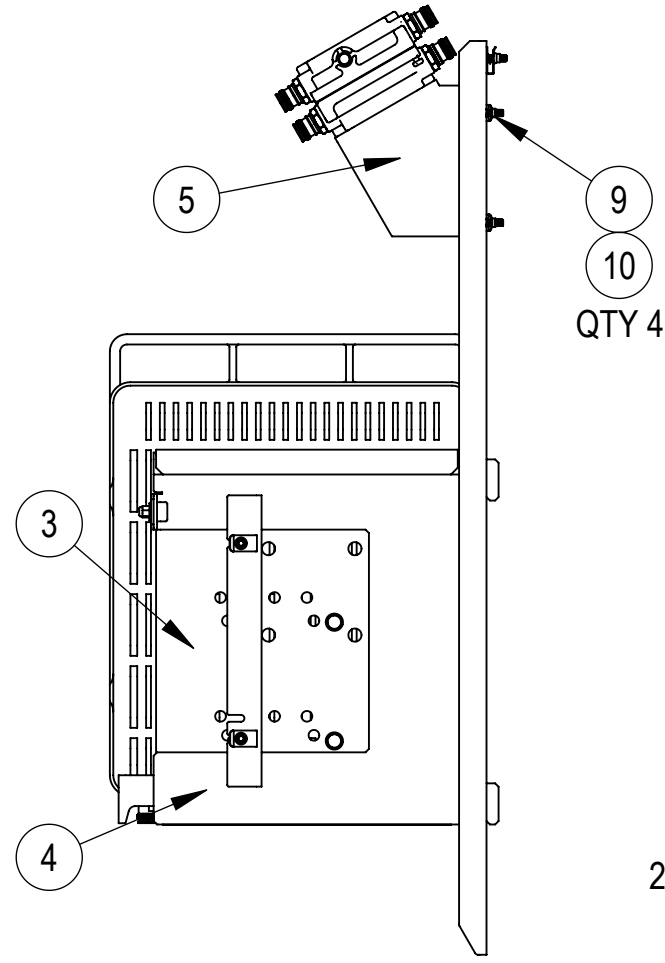
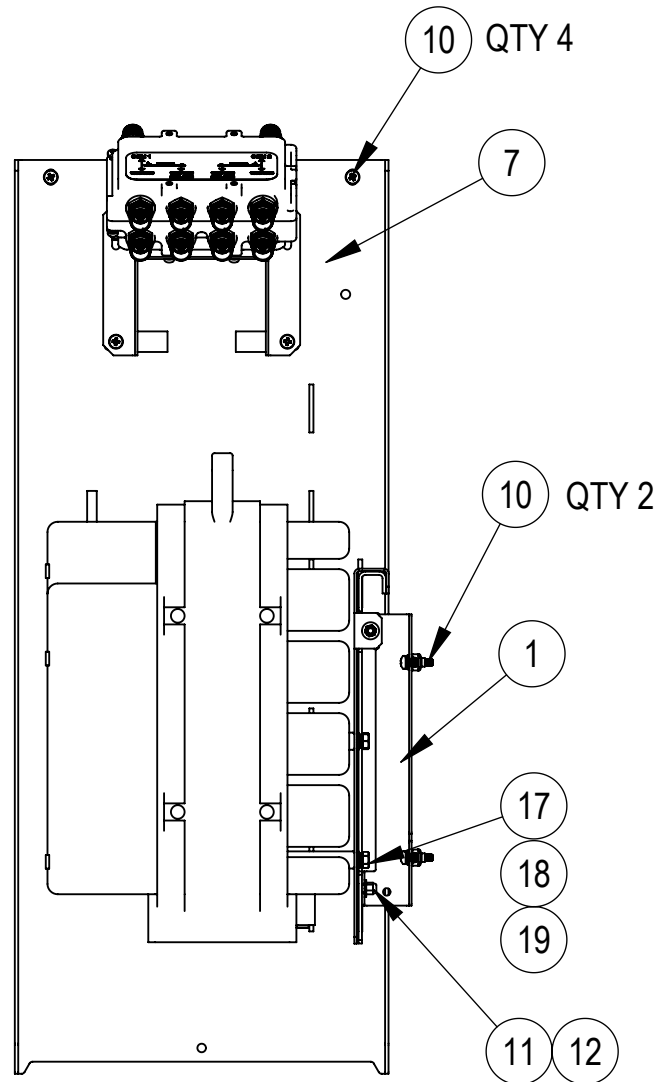

**STEP 3 :
MTM1193-1111-BR**

1. INSTALL ONE SIDE OF THE MOUNTING BRACKET MTM1193-1111-BR TO BRACKET OF ASSEMBLY USING 2 SETS OF M6 SEMS SCREWS, CLIP NUTS AND THE OTHER SIDE (AVOIDED SLOT) TO THE MOUNTING BRACKET MTM1160-1162-BR USING 2 SETS OF 1/4" NUTS, FLAT WASHERS

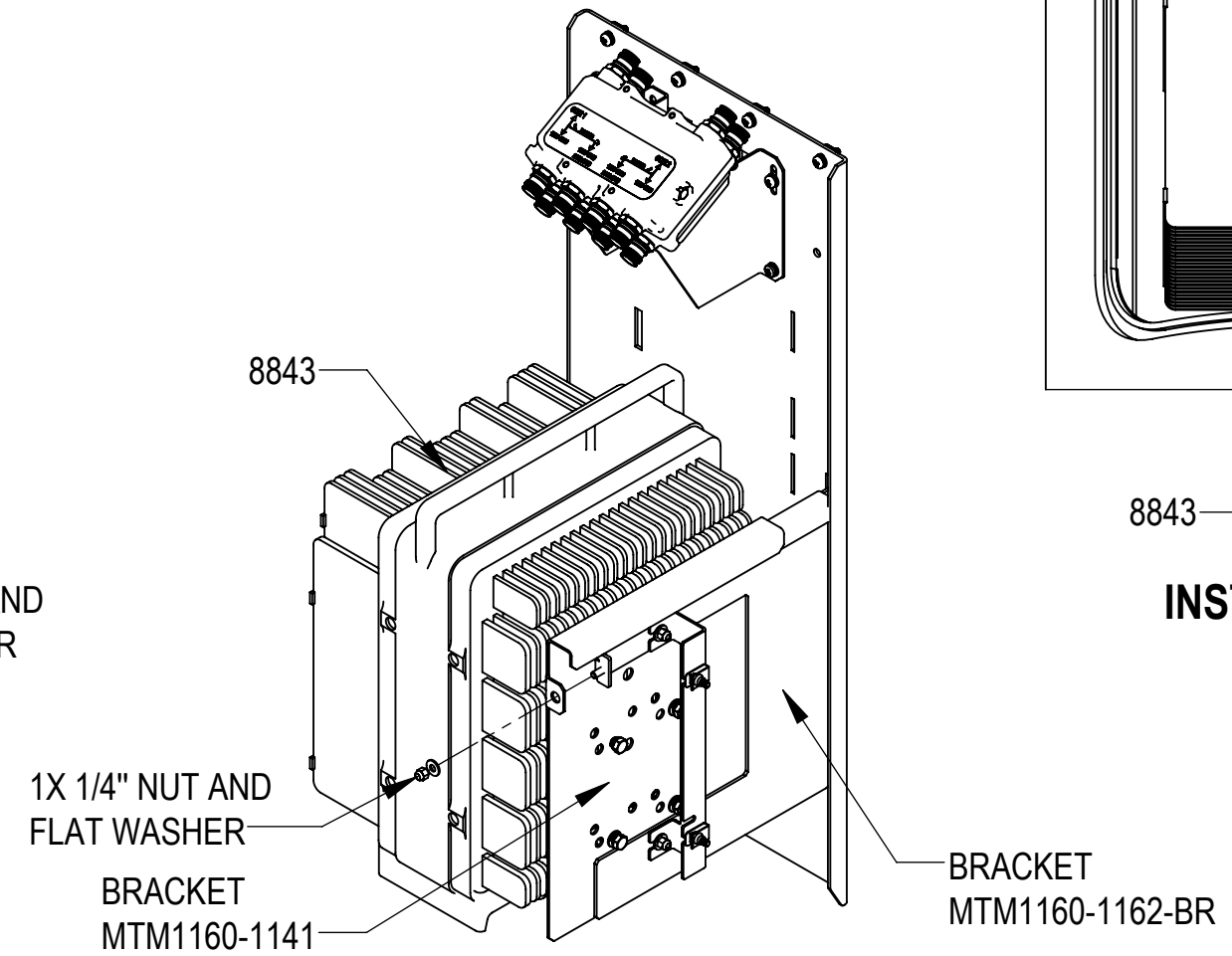

**STEP 4 :
MTM1160-1141-BR (8843)**

1. HANG THE MOUNTING BRACKET MTM1160-1141-BR TO THE MOUNTING BRACKET MTM1160-1162-BR AND LOCK THE SIDE USING 1 SET OF 1/4" NUT AND FLAT WASHER

BOM FOR 8843 + QUAD DIPLEXER SDX1926Q-43 INSTALLATION

ITEM NO.	PART NUMBER	DESCRIPTION	QTY.
1	MTM1193-1111-BR	BRKT SM SPRT 4 HOOK & HANG PB20GA-0.375	1
3	MTM1160-1141-BR	BRKT SLIDE HANGER ERICSON PB20GA	1
4	MTM1160-1162-BR	BRACKET, HANGING RAIL MOVEABLE PB20GA	1
5	MTM1160-1167-BR	BRKT DIPLEX MNTG TOP/ANGLE PB20GA	1
7	MTM1160-1169-BR	BRKT MAIN HK & HANG REAR PLT PB20GA	1
9	460143456	CLIP NUT, M6, 316 SST	4
10	100117-4	FA,SEMS,PH,XRES,M6X25,SST,PASS	10
11	SNYL02	1/4" SS NYLOCK HEX NUT	3
12	SWF-02	FLAT WASHER, 1/4" SS	3
17	MTC9415	M8 X 25mm HEX BOLT SS	4
18	MTC9418	M8 LOCK WASHER SS	4
19	MTC9419	M8 FLAT WASHER SS	4

E2: 8843 + QUAD DIPLEXER SDX1926Q-43 INSTALLATION

EQUIPMENT INSTALLATION SEE SHEET 4 & 5
TORQUE ALL TO SPEC

ANDREW an Amphenol company

TITLE
KIT ERICSSON INSTALL INTO PB20GA-0.375

SIZE **C** SCALE **1:10** DOCUMENT NO. MTM1193-1101-AMK-E

DRAWING			SHEET 7 OF 21
VERSION 04	STATUS RE	REVISION E	

Confidential

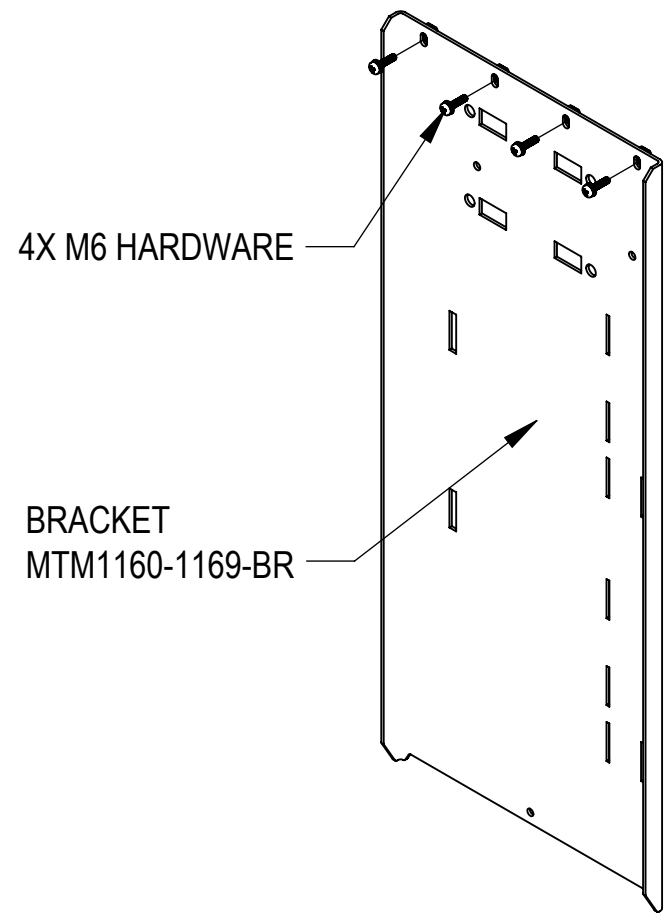
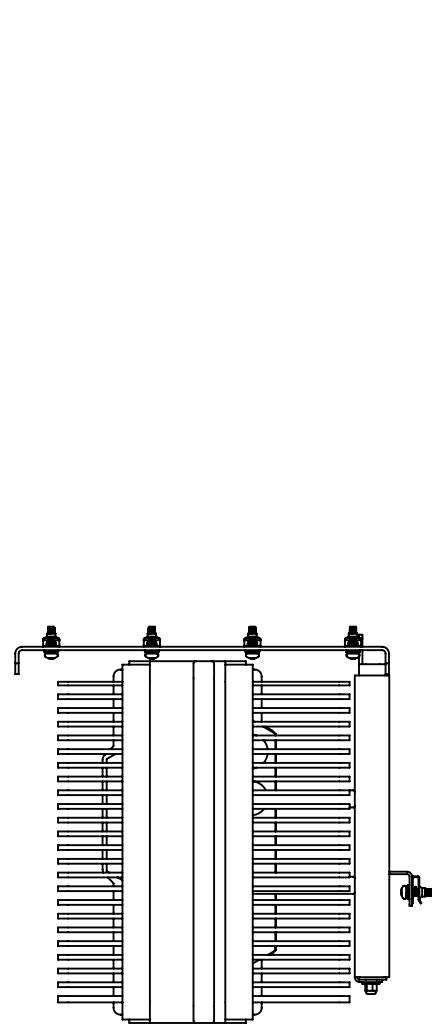

STEP 1 :
MTM1160-1169-BR
 1. INSTALL M6 CLIP NUTS AS SHOWN
 2. INSTALL THE MOUNTING BRACKET MTM1160-1169-BR TO BRACKET OF ASSEMBLY USING 4 SETS OF M6 SEMS SCREWS AND CLIP NUTS

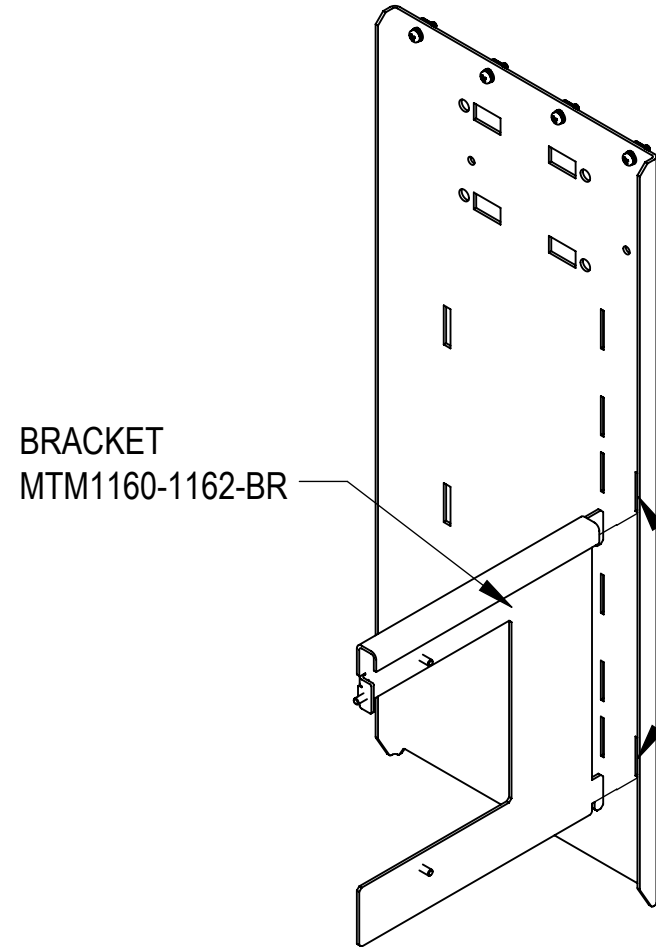

STEP 2 :
MTM1160-1162-BR
 1. HANG THE MOUNTING BRACKET MTM1160-1162-BR TO THE 3RD AND 6TH HOLES FROM THE BOTTOM OF THE MOUNTING BRACKET MTM1160-1169-BR

THE INSTALLATION POSITIONS ARE THE 3RD AND 6TH HOLES FROM THE BOTTOM

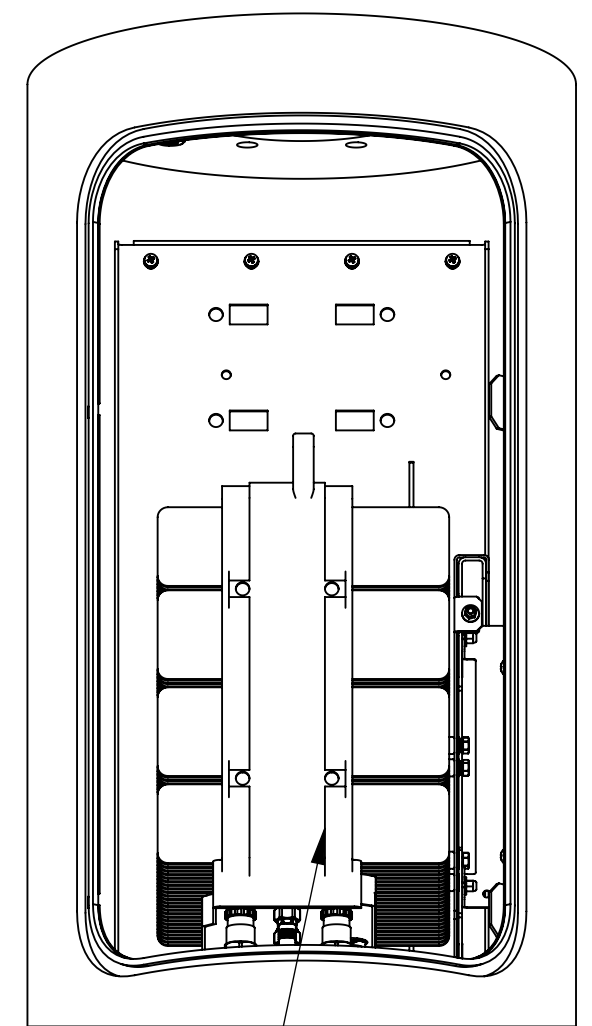

INSTALLED VIEW

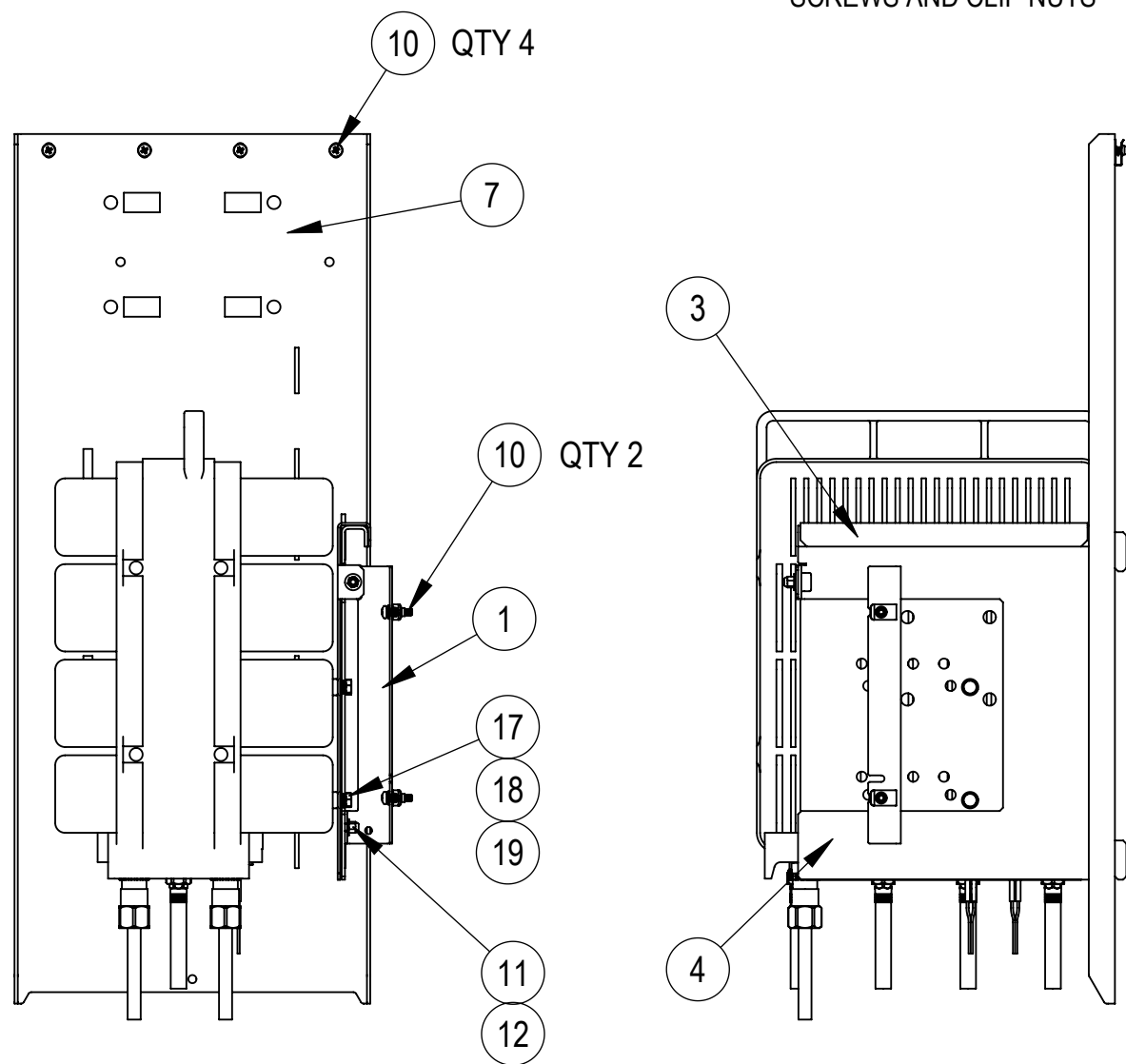

BOM FOR 4449 INSTALLATION

ITEM NO.	PART NUMBER	DESCRIPTION	QTY.
1	MTM1193-1111-BR	BRKT SM SPRT 4 HOOK & HANG PB20GA-0.375	1
3	MTM1160-1141-BR	BRKT SLIDE HANGER ERICSON PB20GA	1
4	MTM1160-1162-BR	BRACKET, HANGING RAIL MOVEABLE PB20GA	1
7	MTM1160-1169-BR	BRKT MAIN HK & HANG REAR PLT PB20GA	1
10	100117-4	FA,SEMS,PH,XRES,M6X25,SST,PASS	6
11	SNYL02	1/4" SS NYLOCK HEX NUT	3
12	SWF-02	FLAT WASHER, 1/4" SS	3
17	MTC9415	M8 X 25mm HEX BOLT SS	4
18	MTC9418	M8 LOCK WASHER SS	4
19	MTC9419	M8 FLAT WASHER SS	4

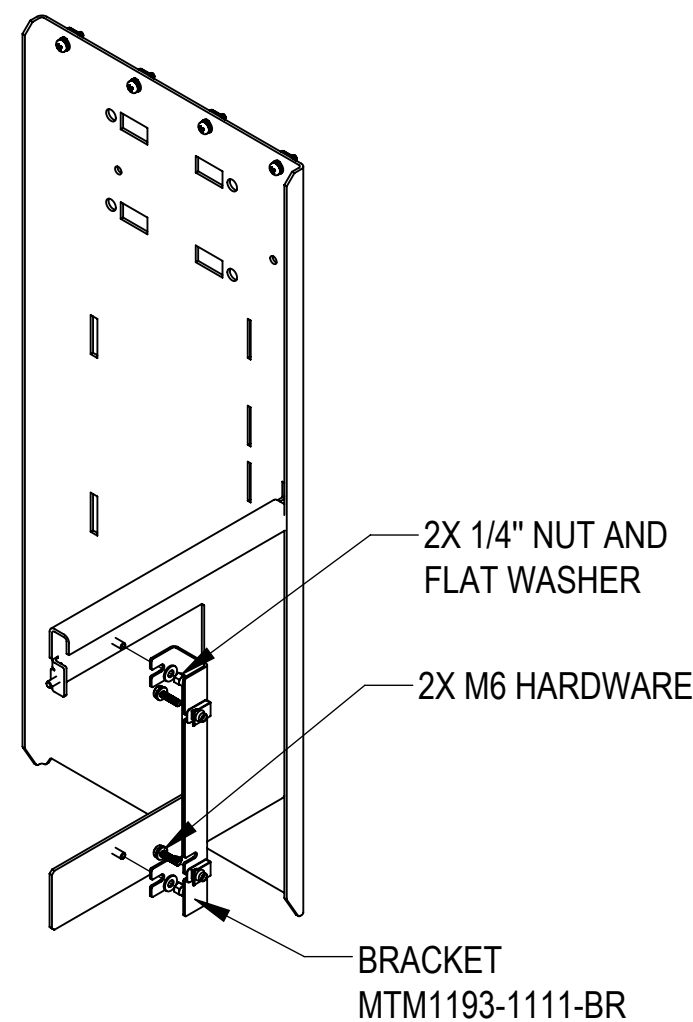

STEP 3 :
MTM1193-1111-BR
 1. INSTALL ONE SIDE OF THE MOUNTING BRACKET MTM1193-1111-BR TO BRACKET OF ASSEMBLY USING 2 SETS OF M6 SEMS SCREWS, CLIP NUTS AND THE OTHER SIDE (AVOIDED SLOT) TO THE MOUNTING BRACKET MTM1160-1162-BR USING 2 SETS OF 1/4" NUTS, FLAT WASHERS

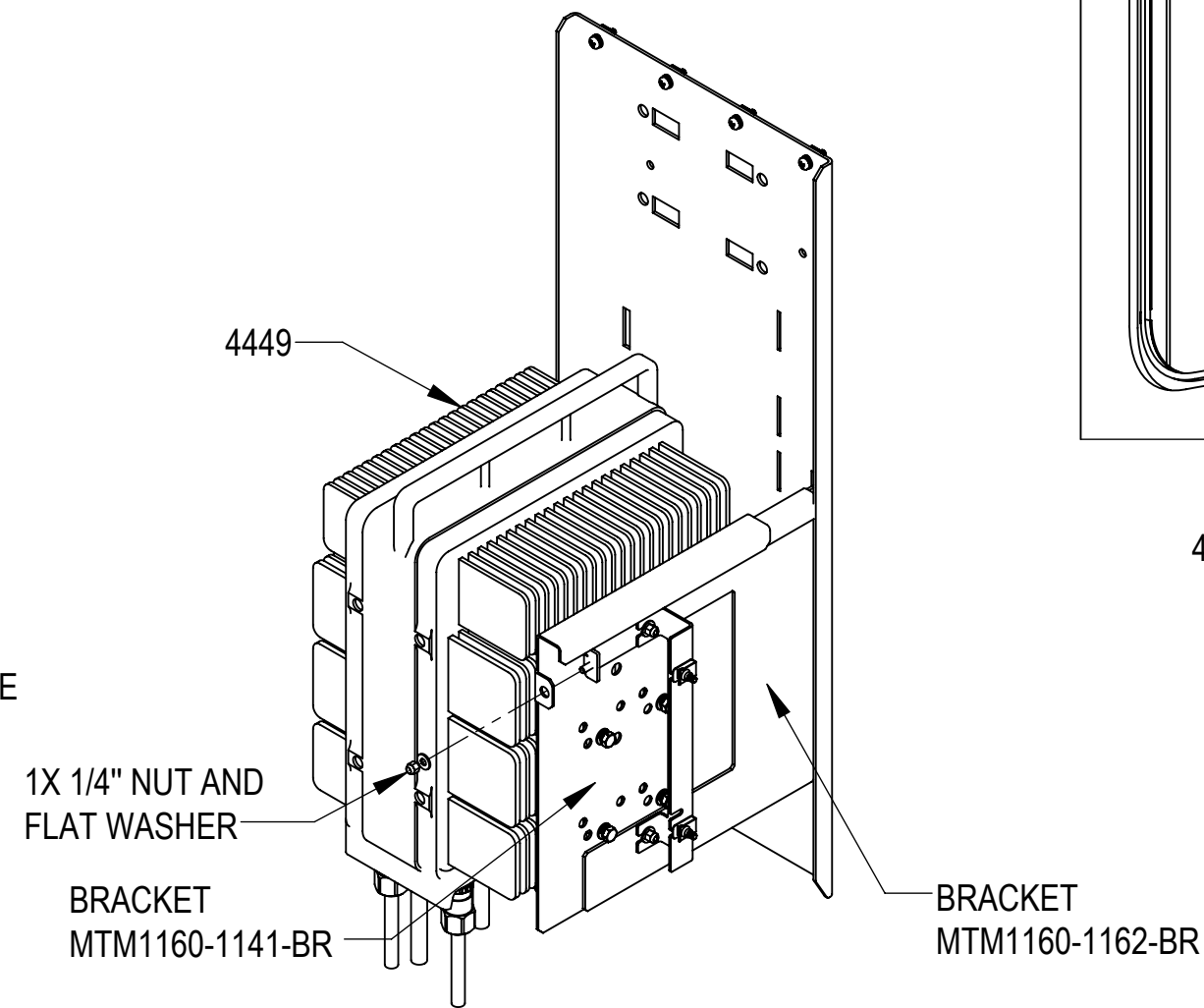

STEP 4 :
MTM1160-1141-BR (ERC 4449)
 1. HANG THE MOUNTING BRACKET MTM1160-1141-BR TO THE MOUNTING BRACKET MTM1160-1162-BR AND LOCK THE SIDE USING 1 SET OF 1/4" NUT AND FLAT WASHER

E3: 4449 INSTALLATION

EQUIPMENT INSTALLATION SEE SHEET 4
 TORQUE ALL TO SPEC



TITLE
 KIT ERICSSON INSTALL INTO PB20GA-0.375

SIZE C	SCALE 1:10	DOCUMENT NO. MTM1193-1101-AMK-E			
		DRAWING			SHEET 8 OF 21
		VERSION 04	STATUS RE	REVISION E	

Confidential

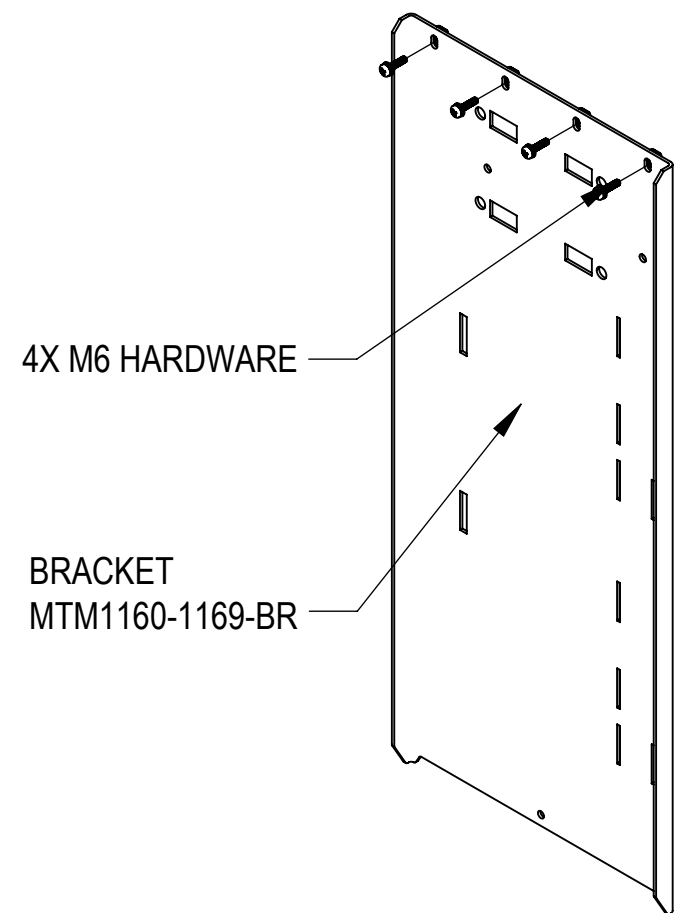
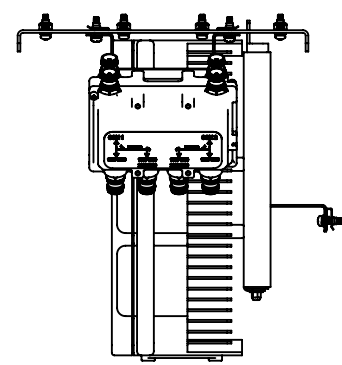

STEP 1 :
MTM1160-1169-BR
 1. INSTALL THE MOUNTING BRACKET MTM1160-1169-BR TO BRACKET OF ASSEMBLY USING 4 SETS OF M6 SEMS ' SCREWS AND CLIP NUTS

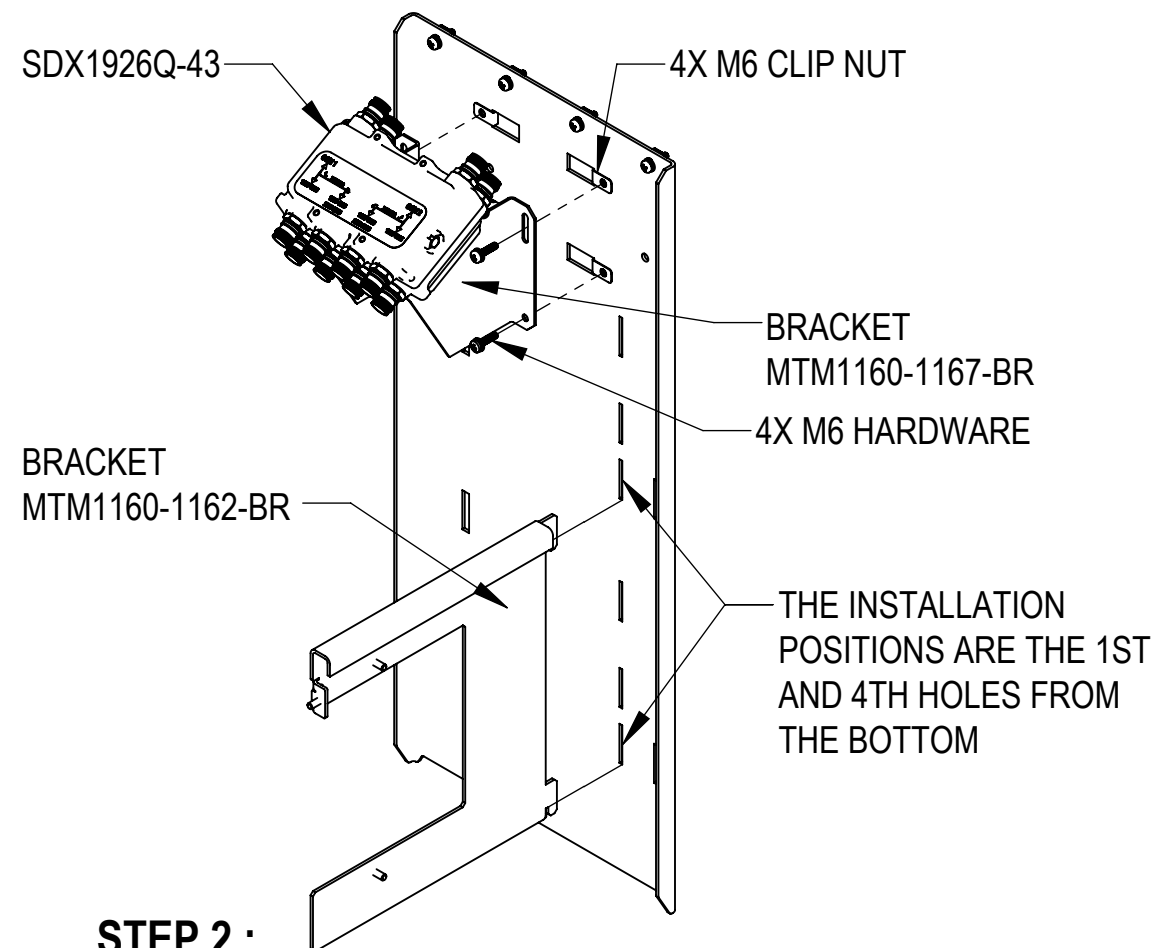

STEP 2 :
MTM1160-1167-BR (SDX1926Q-43) + MTM1160-1162-BR
 1. INSTALL M6 CLIP NUTS AS SHOWN
 2. NSTALL THE MOUNTING BRACKET MTM1160-1167-BR TO THE MOUNTING BRACKET MTM1160-1169-BR USING 4 SETS OF M6 SEMS SCREWS.
 3. HANG THE MOUNTING BRACKET MTM1160-1162-BR TO THE 1ST AND 4TH HOLES FROM THE BOTTOM OF THE MOUNTING BRACKET MTM1160-1169-BR

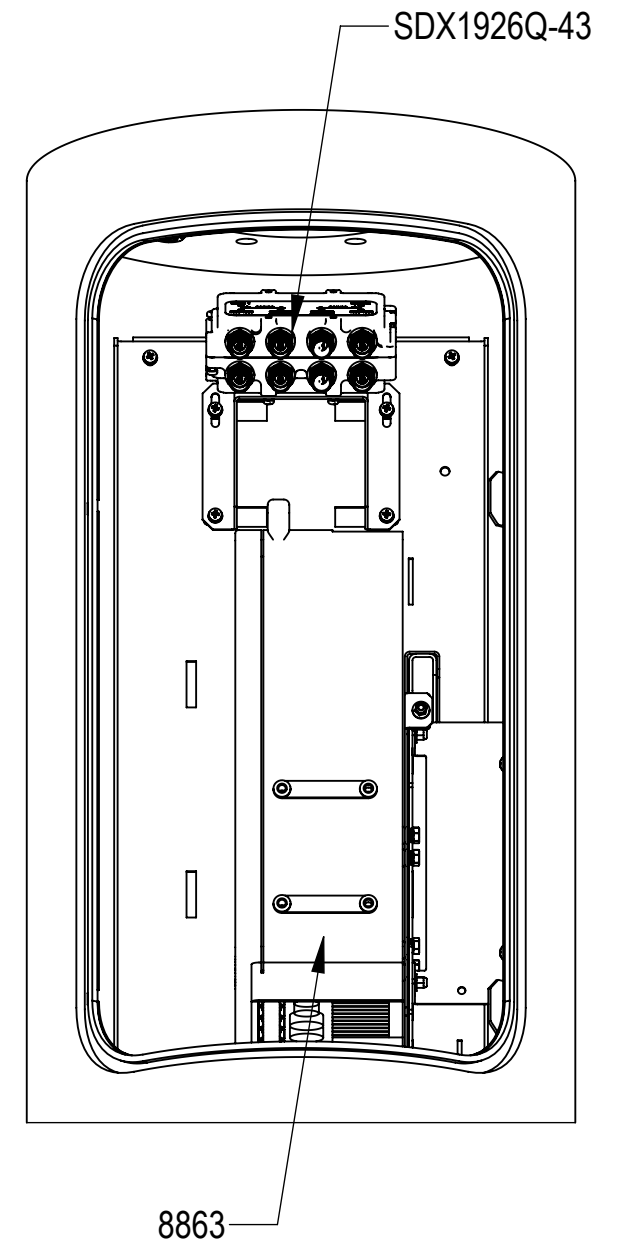

INSTALLED VIEW

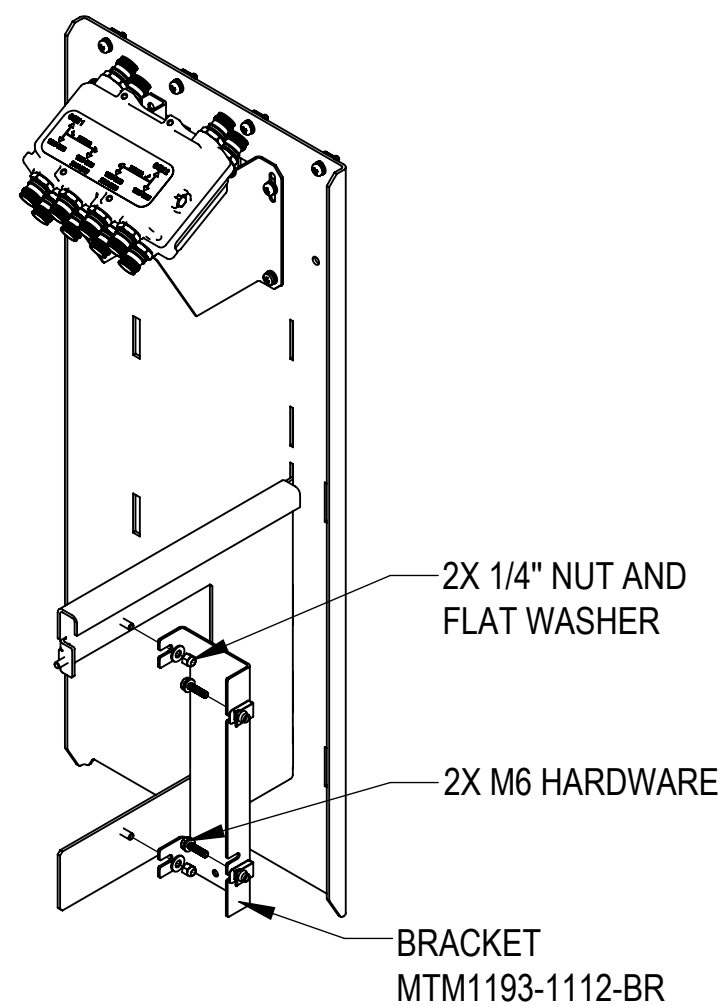
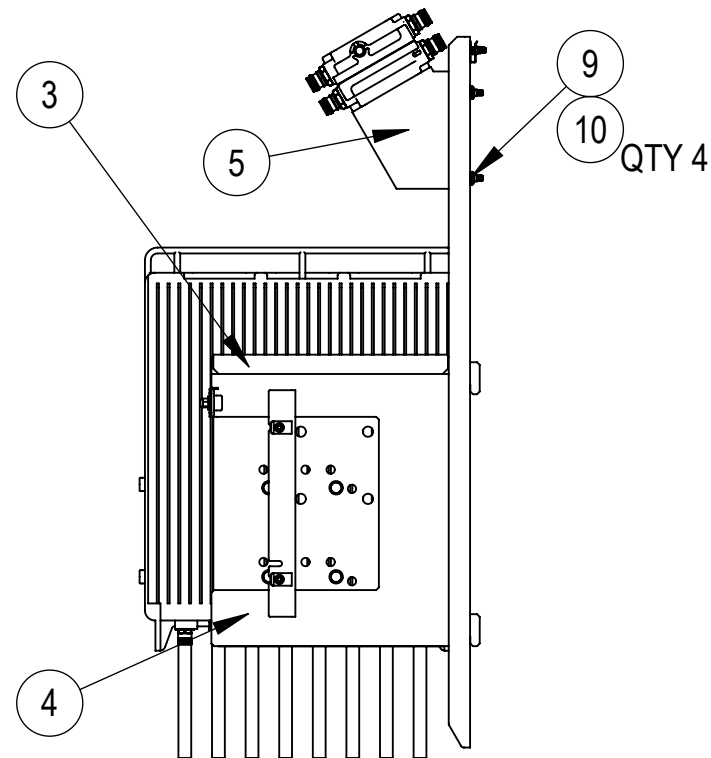
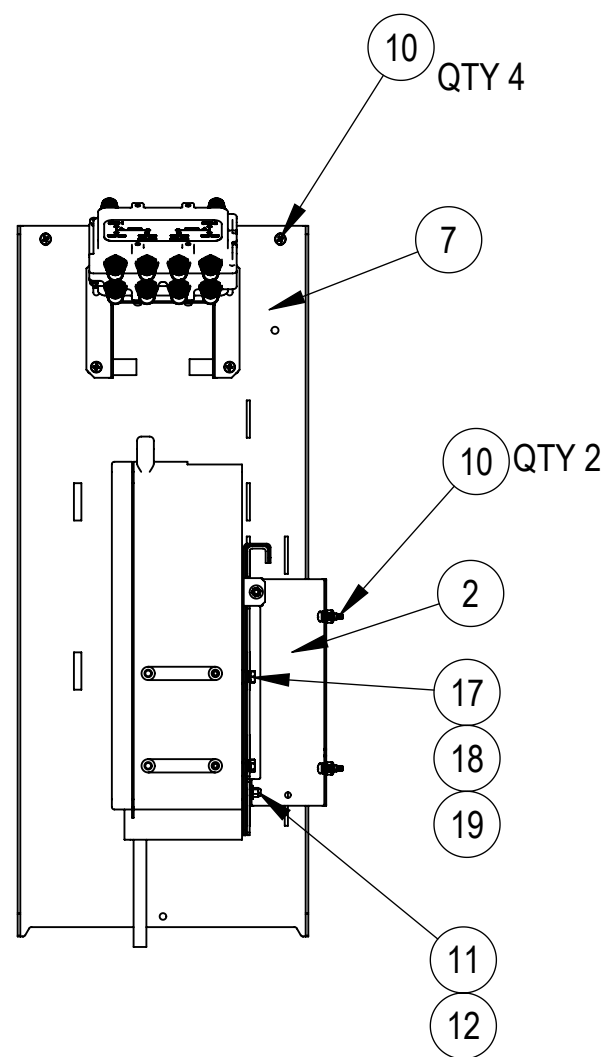

STEP 3 :
MTM1193-1112-BR
 1. INSTALL ONE SIDE OF THE MOUNTING BRACKET MTM1193-1112-BR TO BRACKET OF ASSEMBLY USING 2 SETS OF M6 SEMS SCREWS, CLIP NUTS AND THE OTHER SIDE (AVOIDED SLOT) TO THE MOUNTING BRACKET MTM1160-1162-BR USING 2 SETS OF 1/4" NUTS, FLAT WASHERS

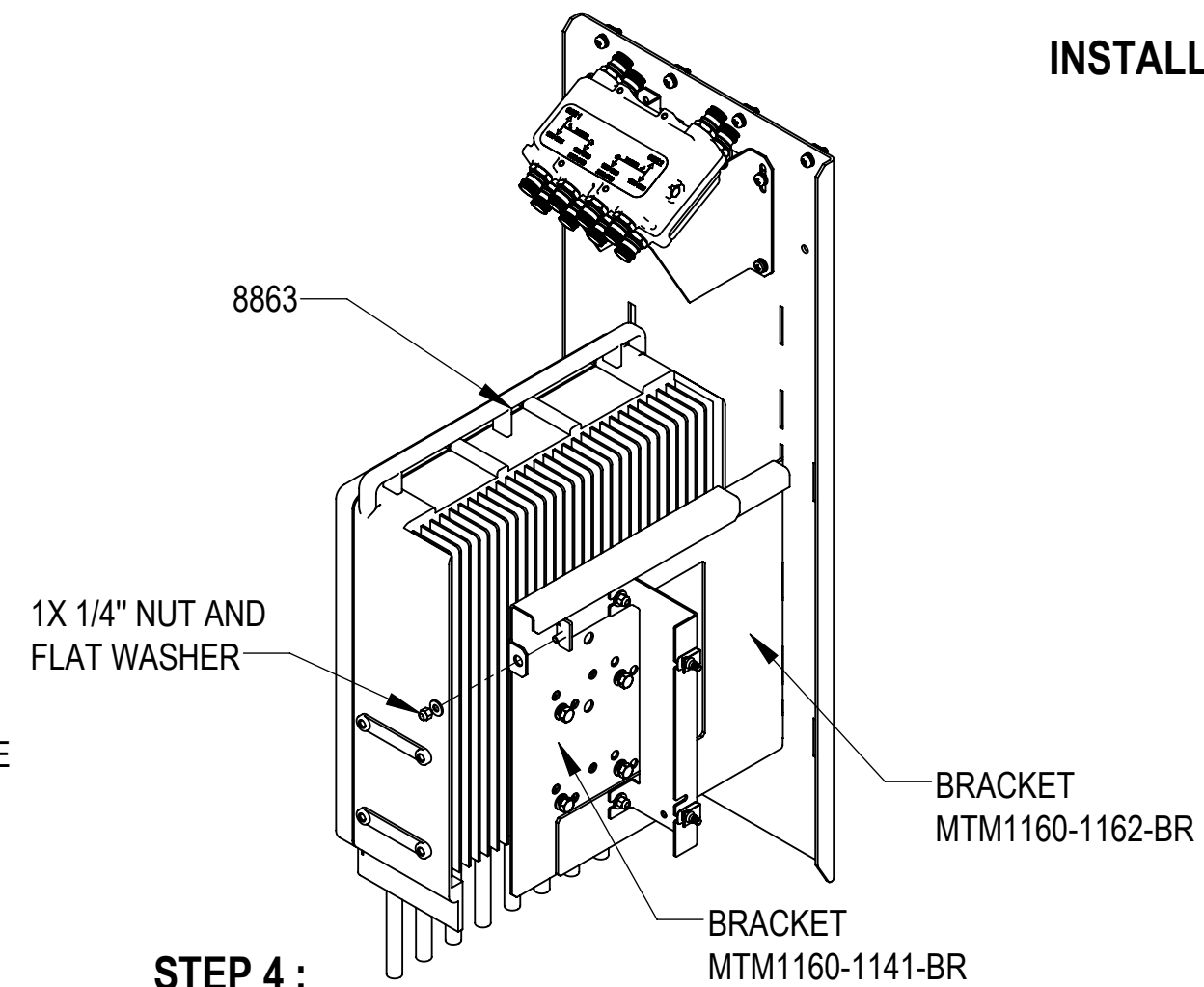

STEP 4 :
MTM1160-1141-BR (8863)
 1. HANG THE MOUNTING BRACKET MTM1160-1141-BR TO THE MOUNTING BRACKET MTM1160-1162-BR AND LOCK THE SIDE USING 1 SET OF 1/4" NUT AND FLAT WASHER

BOM FOR 8863 + QUAD DIPLEXER SDX1926Q-43 INSTALLATION

ITEM NO.	PART NUMBER	DESCRIPTION	QTY.
2	MTM1193-1112-BR	BRKT LG SPRT 4 HOOK & HANG PB20GA-0.375	1
3	MTM1160-1141-BR	BRKT SLIDE HANGER ERCISON PB20GA	1
4	MTM1160-1162-BR	BRACKET, HANGING RAIL MOVEABLE PB20GA	1
5	MTM1160-1167-BR	BRKT DIPLEX MNTG TOP/ANGLE PB20GA	1
7	MTM1160-1169-BR	BRKT MAIN HK & HANG REAR PLT PB20GA	1
9	460143456	CLIP NUT, M6, 316 SST	4
10	100117-4	FA,SEMS,PH,XRES,M6X25,SST,PASS	10
11	SNYL02	1/4" SS NYLOCK HEX NUT	3
12	SWF-02	FLAT WASHER, 1/4" SS	3
17	MTC9415	M8 X 25mm HEX BOLT SS	4
18	MTC9418	M8 LOCK WASHER SS	4
19	MTC9419	M8 FLAT WASHER SS	4

E4: 8863 + QUAD DIPLEXER SDX1926Q-43 INSTALLATION

EQUIPMENT INSTALLATION SEE SHEET 4 & 5
 TORQUE ALL TO SPEC



TITLE KIT ERICSSON INSTALL INTO PB20GA-0.375				
SIZE C	SCALE 1:10	DOCUMENT NO. MTM1193-1101-AMK-E		
DRAWING		REVISION		SHEET
VERSION 04	STATUS RE	REVISION E	9 OF 21	

Confidential

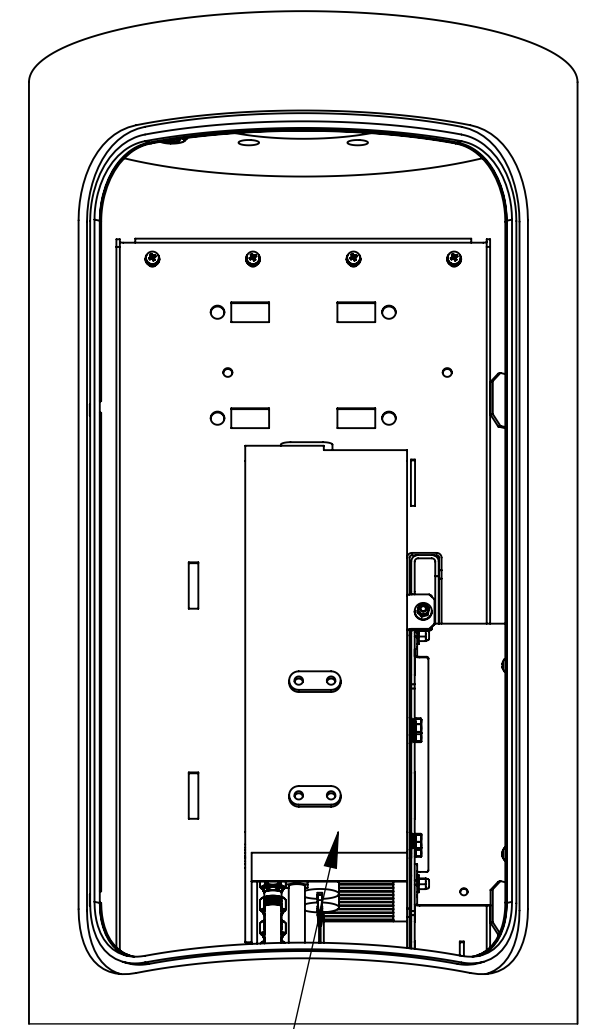
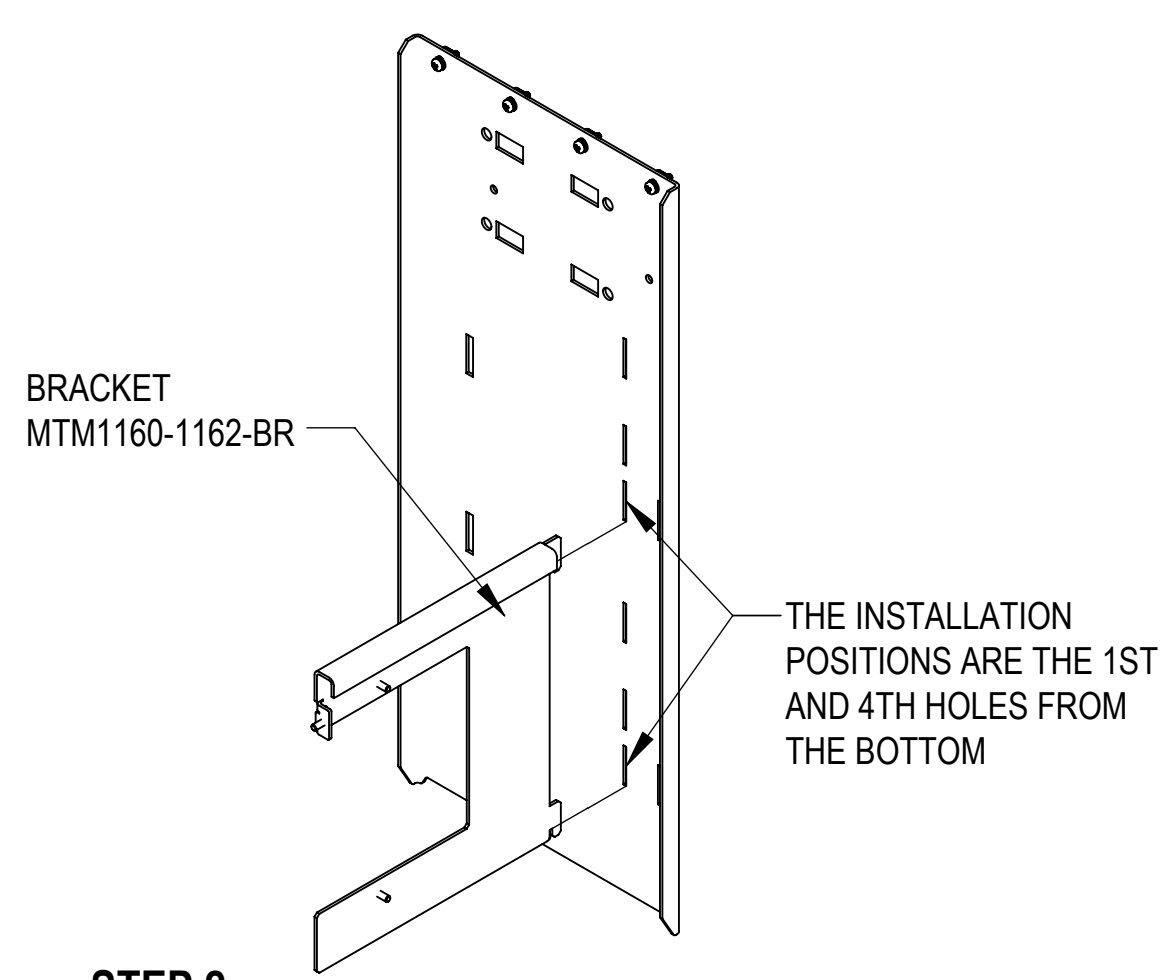
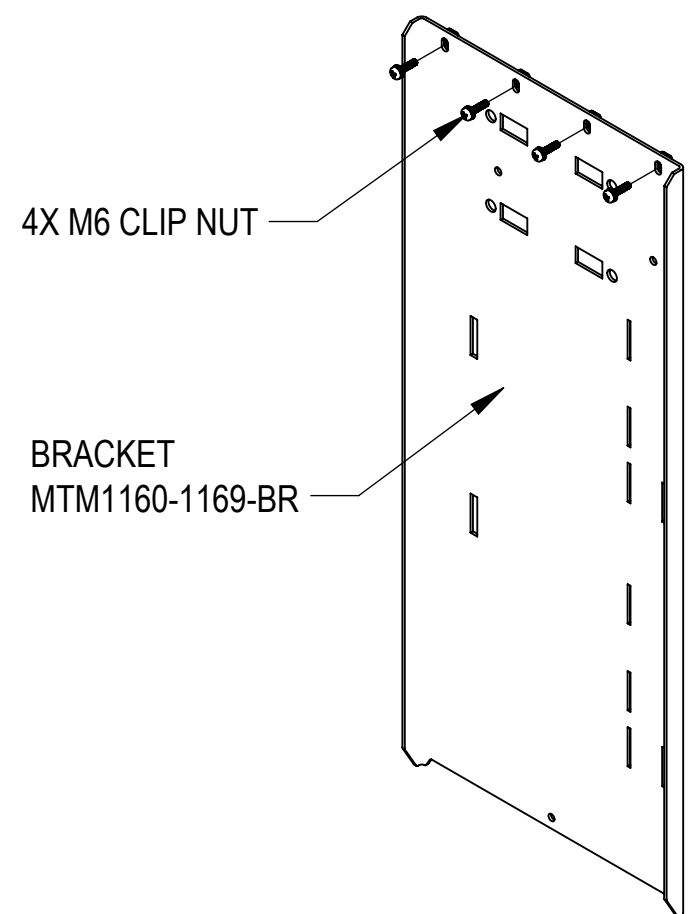
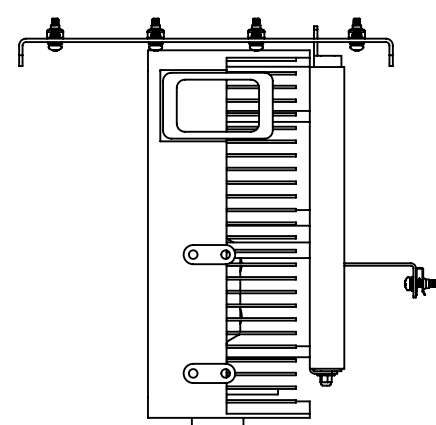

STEP 1 :
MTM1160-1169-BR

1. INSTALL THE MOUNTING BRACKET MTM1160-1169-BR TO BRACKET OF ASSEMBLY USING 4 SETS OF M6 SEMS SCREWS AND CLIP NUTS

STEP 2 :
MTM1160-1162-BR

1. HANG THE MOUNTING BRACKET MTM1160-1162-BR TO THE 1ST AND 4TH HOLES FROM THE BOTTOM OF THE MOUNTING BRACKET MTM1160-1169-BR

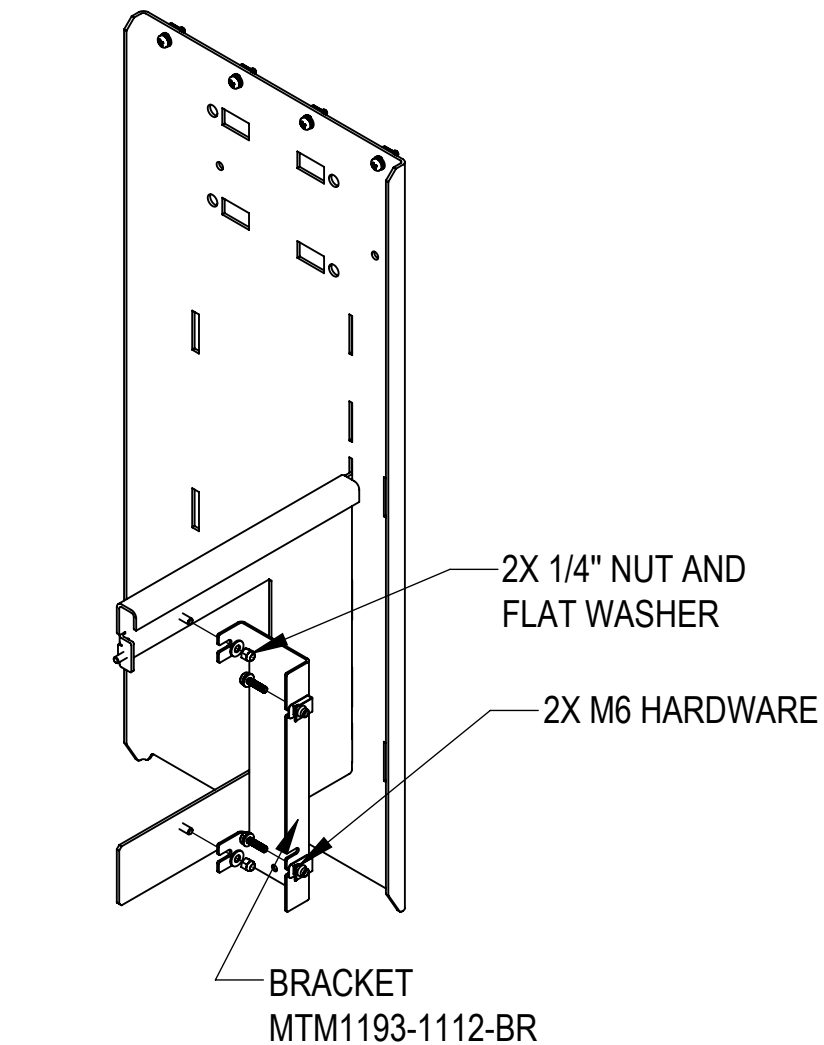
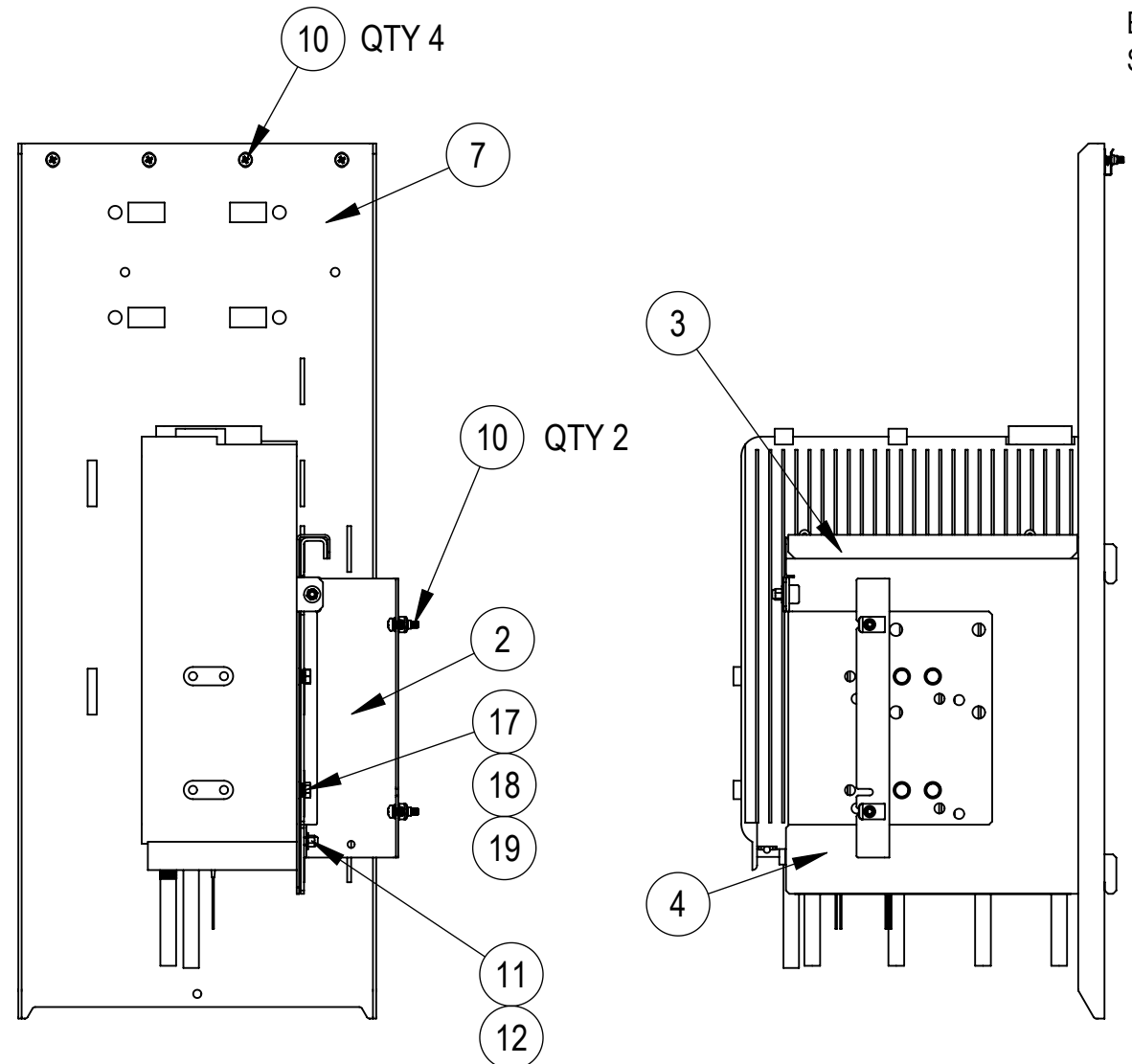

STEP 3 :
MTM1193-1112-BR

1. INSTALL ONE SIDE OF THE MOUNTING BRACKET MTM1193-1112-BR TO BRACKET OF ASSEMBLY USING 2 SETS OF M6 SEMS SCREWS, CLIP NUTS AND THE OTHER SIDE(AVOIDED SLOT) TO THE MOUNTING BRACKET MTM1160-1162-BR USING 2 SETS OF 1/4" NUTS, FLAT WASHERS

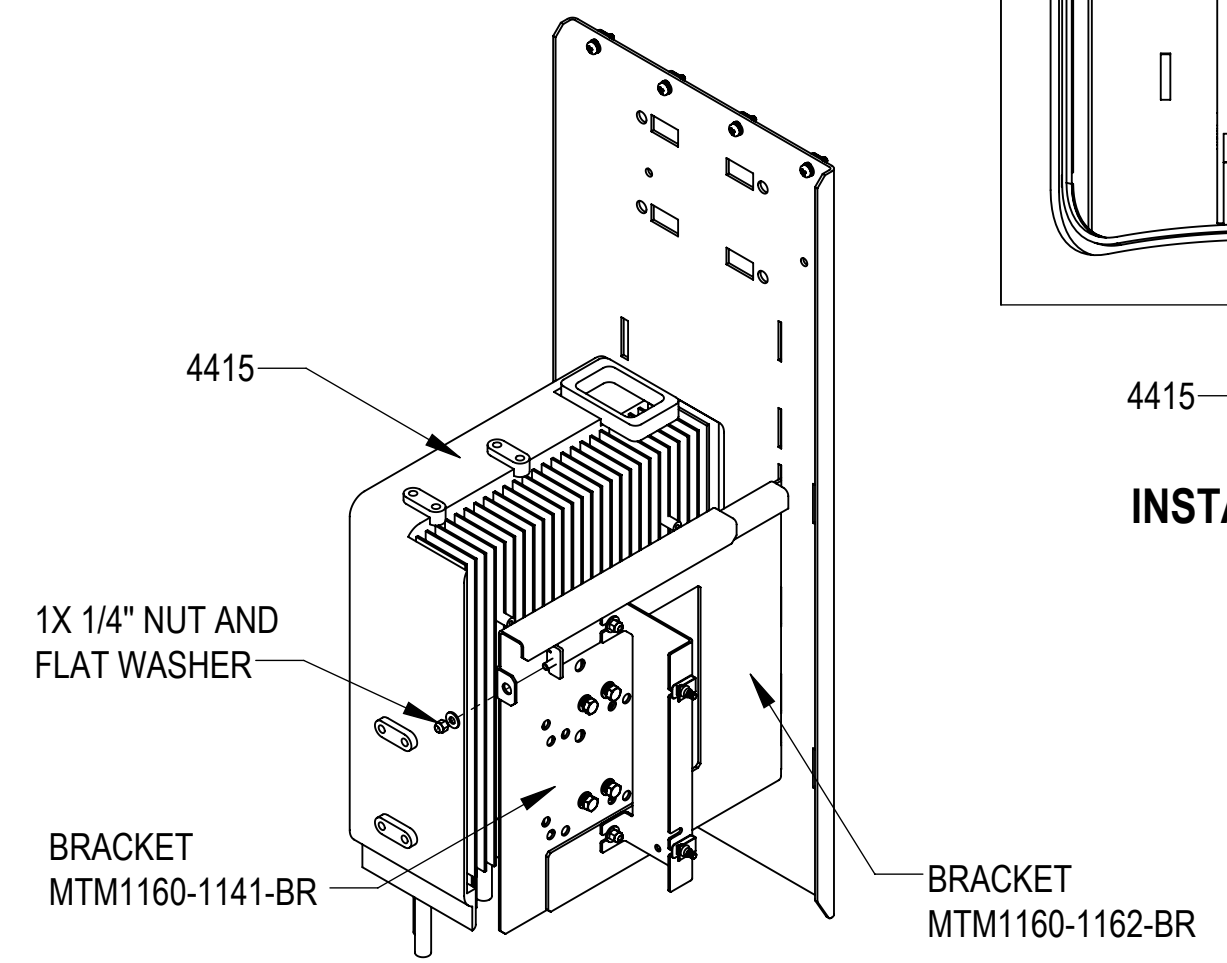

STEP 4 :
MTM1160-1141-BR (4415)

1. HANG THE MOUNTING BRACKET MTM1160-1141-BR TO THE MOUNTING BRACKET MTM1160-1162-BR AND LOCK THE SIDE USING 1 SET OF 1/4" NUT AND FLAT WASHER

BOM FOR 4415 INSTALLATION

ITEM NO.	PART NUMBER	DESCRIPTION	QTY.
2	MTM1193-1112-BR	BRKT LG SPRT 4 HOOK & HANG PB20GA-0.375	1
3	MTM1160-1141-BR	BRKT SLIDE HANGER ERCISON PB20GA	1
4	MTM1160-1162-BR	BRACKET, HANGING RAIL MOVEABLE PB20GA	1
7	MTM1160-1169-BR	BRKT MAIN HK & HANG REAR PLT PB20GA	1
10	100117-4	FA,SEMS,PH,XRES,M6X25,SST,PASS	6
11	SNYL02	1/4" SS NYLOCK HEX NUT	3
12	SWF-02	FLAT WASHER, 1/4" SS	3
17	MTC9415	M8 X 25mm HEX BOLT SS	4
18	MTC9418	M8 LOCK WASHER SS	4
19	MTC9419	M8 FLAT WASHER SS	4

E5: 4415 INSTALLATION

EQUIPMENT INSTALLATION SEE SHEET 4
TORQUE ALL TO SPEC



TITLE KIT ERICSSON INSTALL INTO PB20GA-0.375			
SIZE C	SCALE 1:10	DOCUMENT NO. MTM1193-1101-AMK-E	
DRAWING			SHEET
VERSION 04	STATUS RE	REVISION E	10 OF 21

Confidential

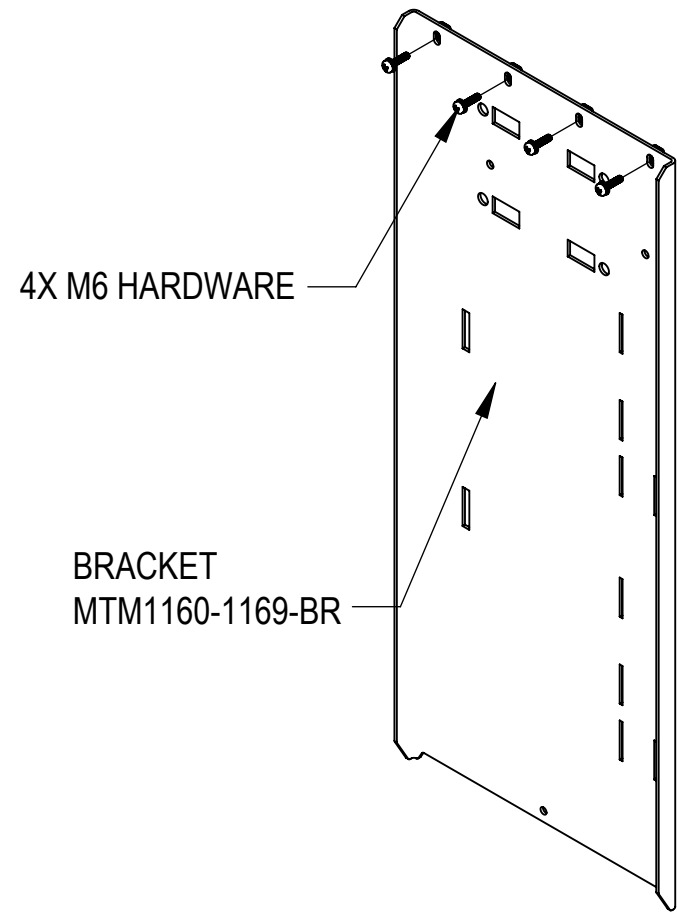

STEP 1 :
MTM1160-1169-BR
1. INSTALL THE MOUNTING BRACKET MTM1160-1169-BR TO BRACKET OF ASSEMBLY USING 4 SETS OF M6 SEMS SCREWS AND CLIP NUTS

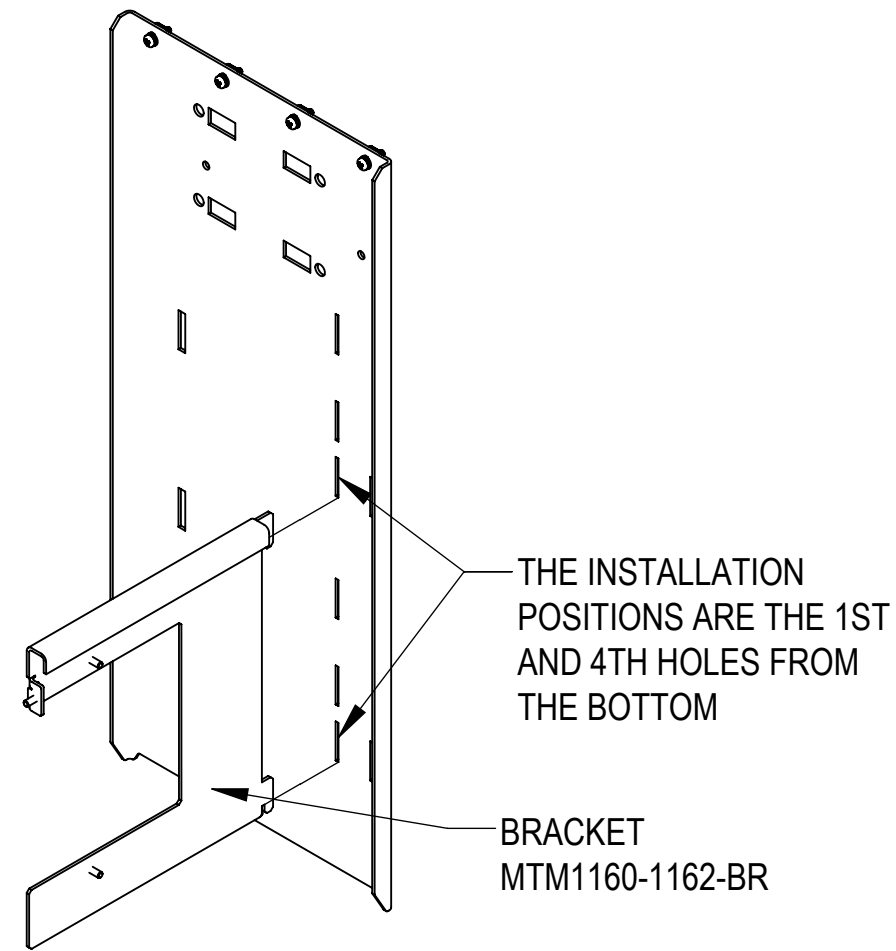

STEP 2 :
MTM1160-1162-BR
1. HANG THE MOUNTING BRACKET MTM1160-1162-BR TO THE 1ST AND 4TH HOLES FROM THE BOTTOM OF THE MOUNTING BRACKET MTM1160-1169-BR

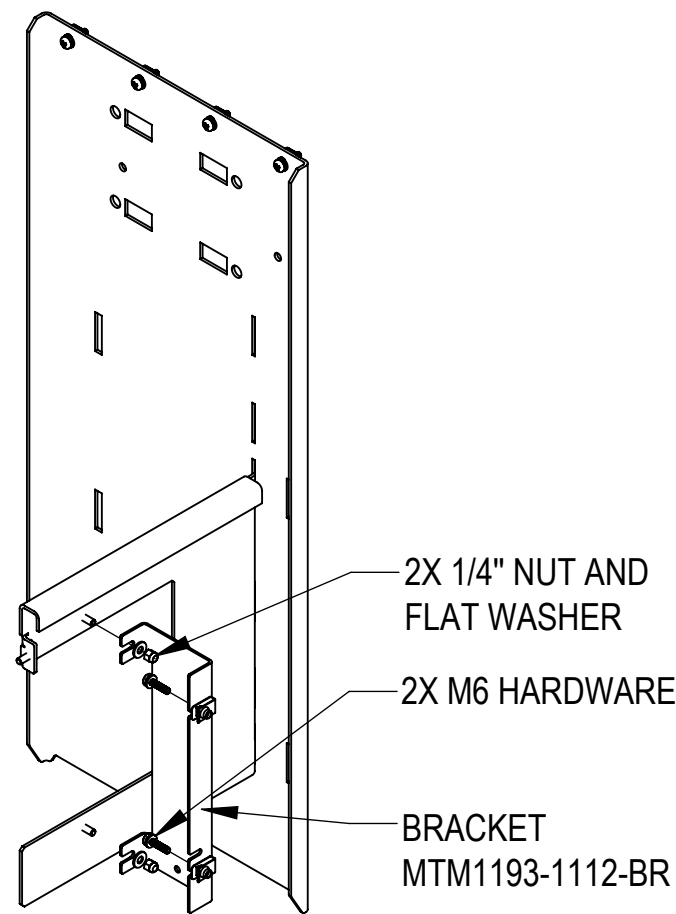
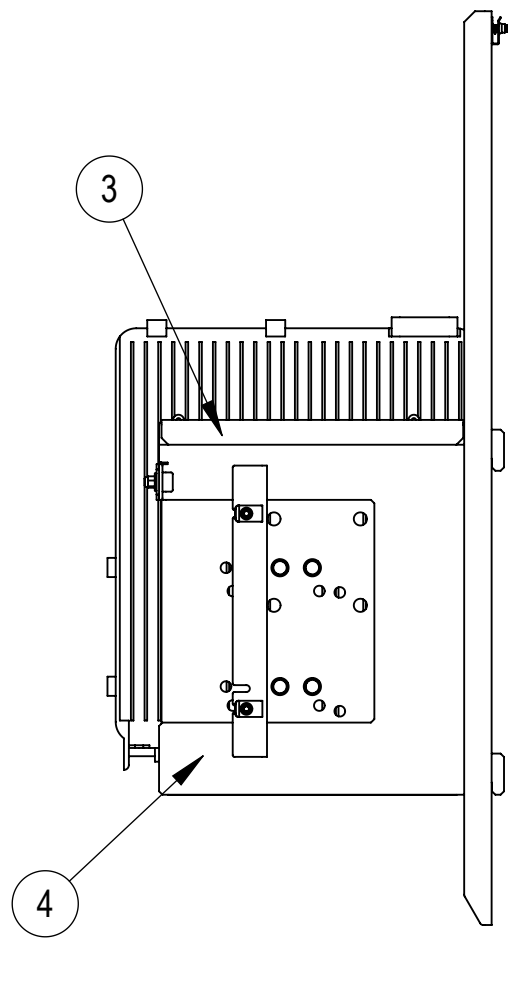
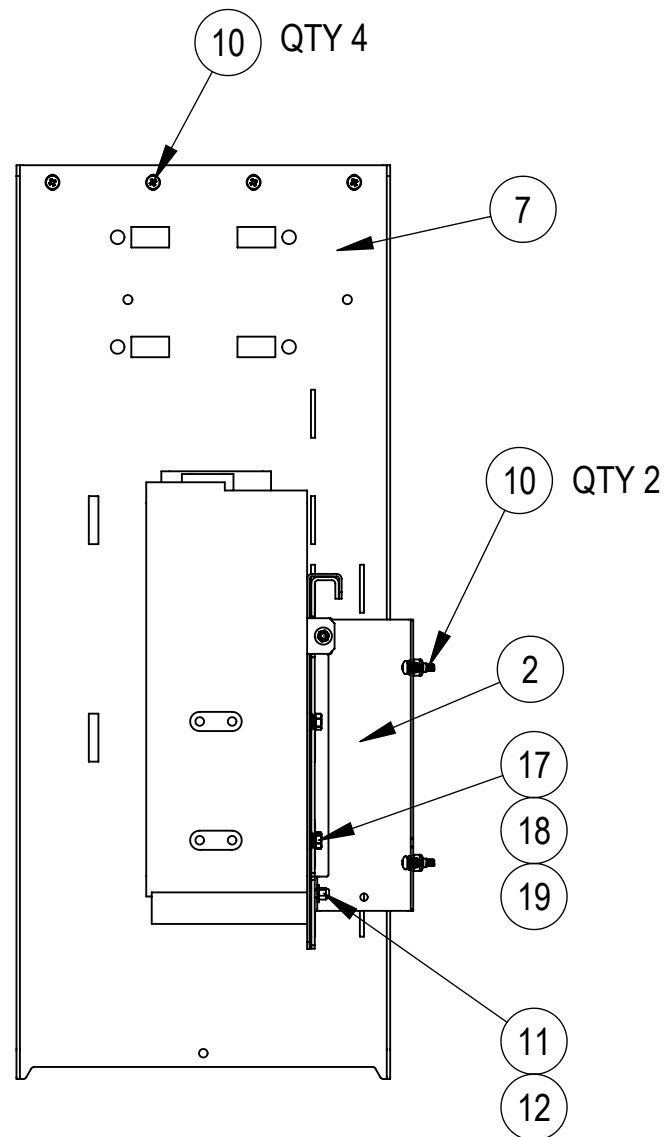
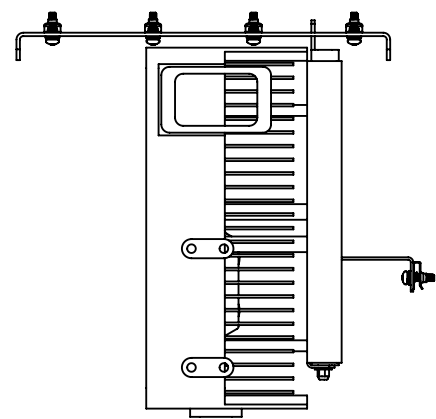

STEP 3 :
MTM1193-1112-BR
1. INSTALL ONE SIDE OF THE MOUNTING BRACKET MTM1193-1112-BR TO BRACKET OF ASSEMBLY USING 2 SETS OF M6 SEMS SCREWS, CLIP NUTS AND THE OTHER SIDE(AVOIDED SLOT) TO THE MOUNTING BRACKET MTM1160-1162-BR USING 2 SETS OF 1/4" NUT AND FLAT WASHERS

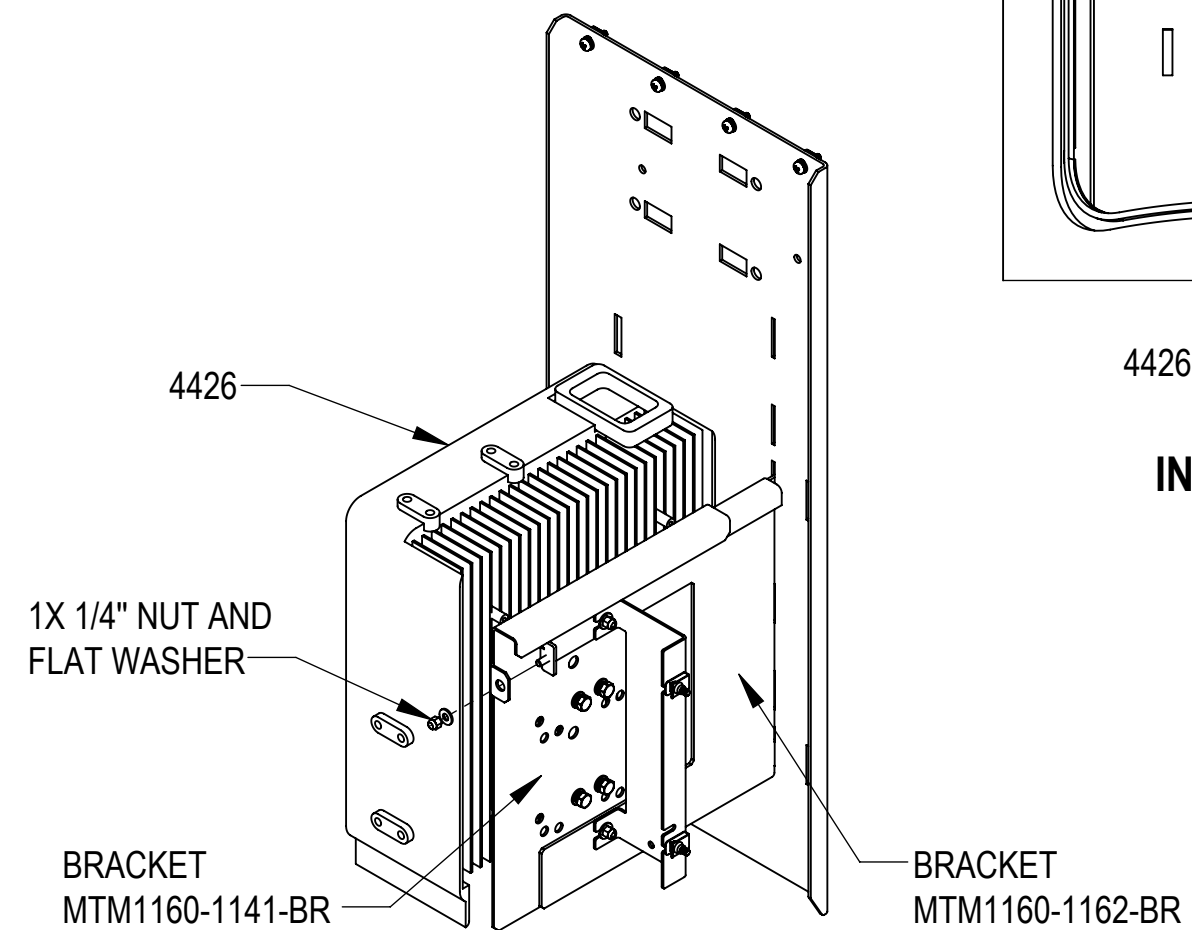

STEP 4 :
MTM1160-1141-BR (4426)
1. HANG THE MOUNTING BRACKET MTM1160-1141-BR TO THE MOUNTING BRACKET MTM1160-1162-BR AND LOCK THE SIDE USING 1 SET OF 1/4" NUT AND FLAT WASHER

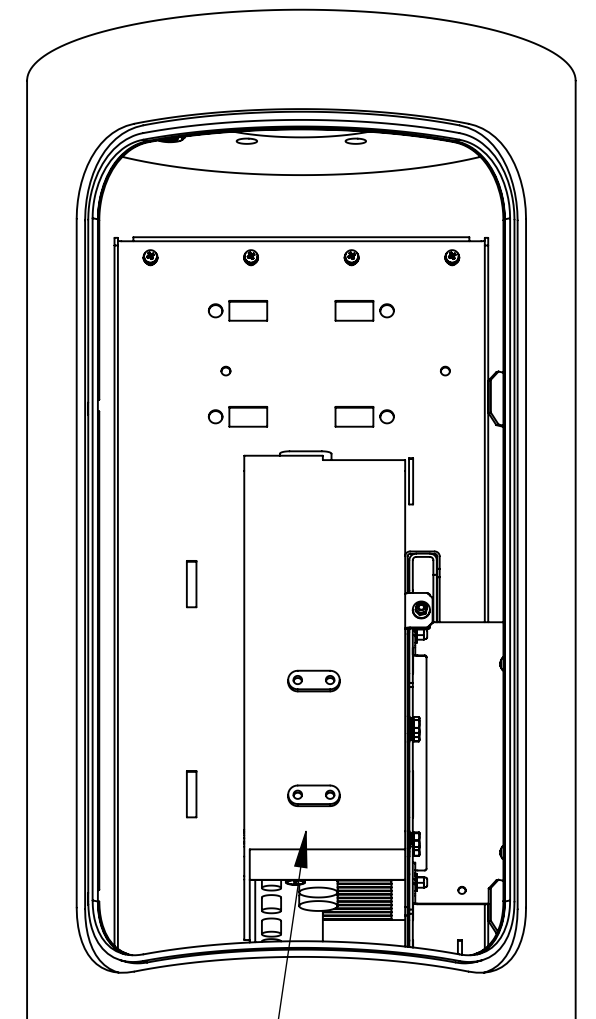

INSTALLED VIEW

BOM FOR 4426 INSTALLATION

ITEM NO.	PART NUMBER	DESCRIPTION	QTY.
2	MTM1193-1112-BR	BRKT LG SPRT 4 HOOK & HANG PB20GA-0.375	1
3	MTM1160-1141-BR	BRKT SLIDE HANGER ERCISON PB20GA	1
4	MTM1160-1162-BR	BRACKET, HANGING RAIL MOVEABLE PB20GA	1
7	MTM1160-1169-BR	BRKT MAIN HK & HANG REAR PLT PB20GA	1
10	100117-4	FA,SEMS,PH,XRES,M6X25,SST,PASS	6
11	SNYL02	1/4" SS NYLOCK HEX NUT	3
12	SWF-02	FLAT WASHER, 1/4" SS	3
17	MTC9415	M8 X 25mm HEX BOLT SS	4
18	MTC9418	M8 LOCK WASHER SS	4
19	MTC9419	M8 FLAT WASHER SS	4

E6: 4426 INSTALLATION

EQUIPMENT INSTALLATION SEE SHEET 4
TORQUE ALL TO SPEC



TITLE KIT ERICSSON INSTALL INTO PB20GA-0.375				
SIZE C	SCALE 1:10	DOCUMENT NO. MTM1193-1101-AMK-E		
DRAWING		VERSION	STATUS	REVISION
		04	RE	E
SHEET 11 OF 21				

Confidential

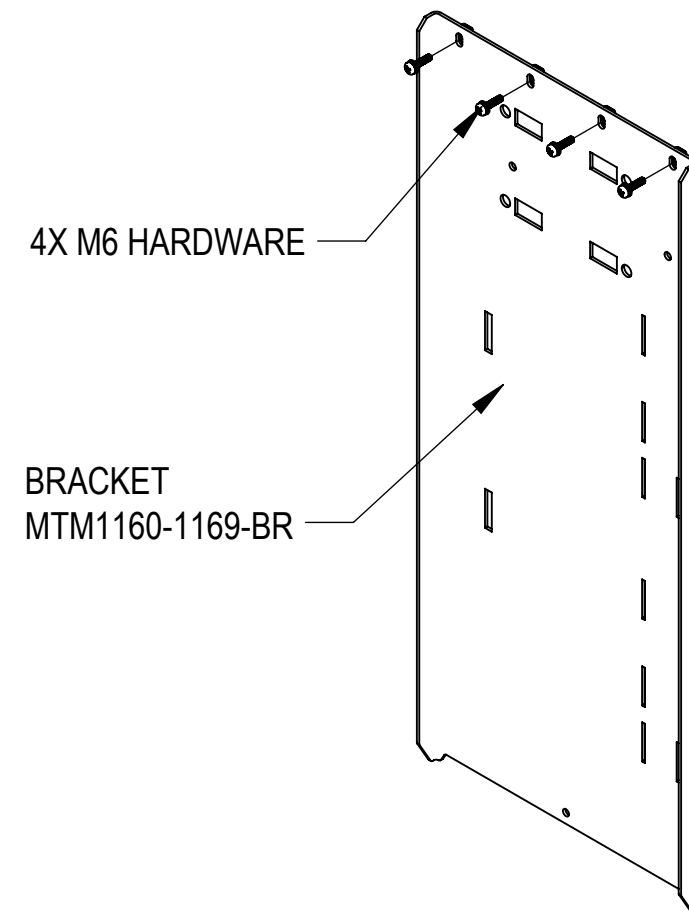
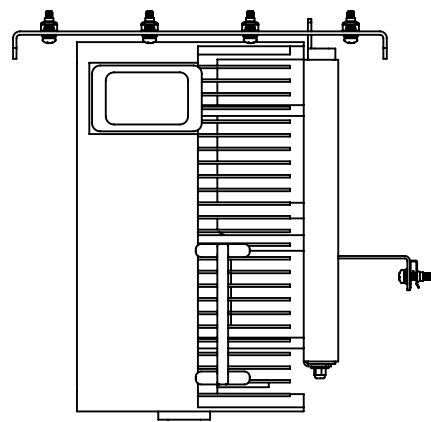

4X M6 HARDWARE
BRACKET
MTM1160-1169-BR

STEP 1 :
MTM1160-1169-BR

1. INSTALL THE MOUNTING BRACKET MTM1160-1169-BR TO BRACKET OF ASSEMBLY USING 4 SETS OF M6 SEMS SCREWS AND CLIP NUTS

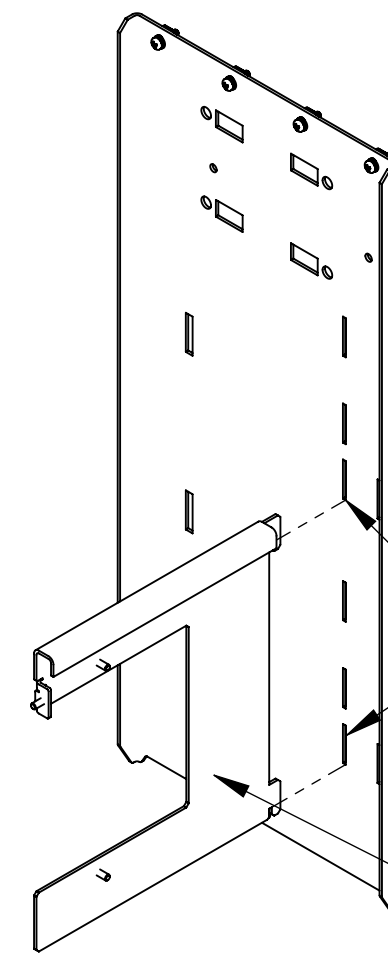

THE INSTALLATION POSITIONS ARE THE 2ND AND 5TH HOLES FROM THE BOTTOM

BRACKET
MTM1160-1162-BR

STEP 2 :
MTM1160-1162-BR

1. HANG THE MOUNTING BRACKET MTM1160-1162-BR TO THE 2ND AND 5TH HOLES FROM THE BOTTOM OF THE MOUNTING BRACKET MTM1160-1169-BR

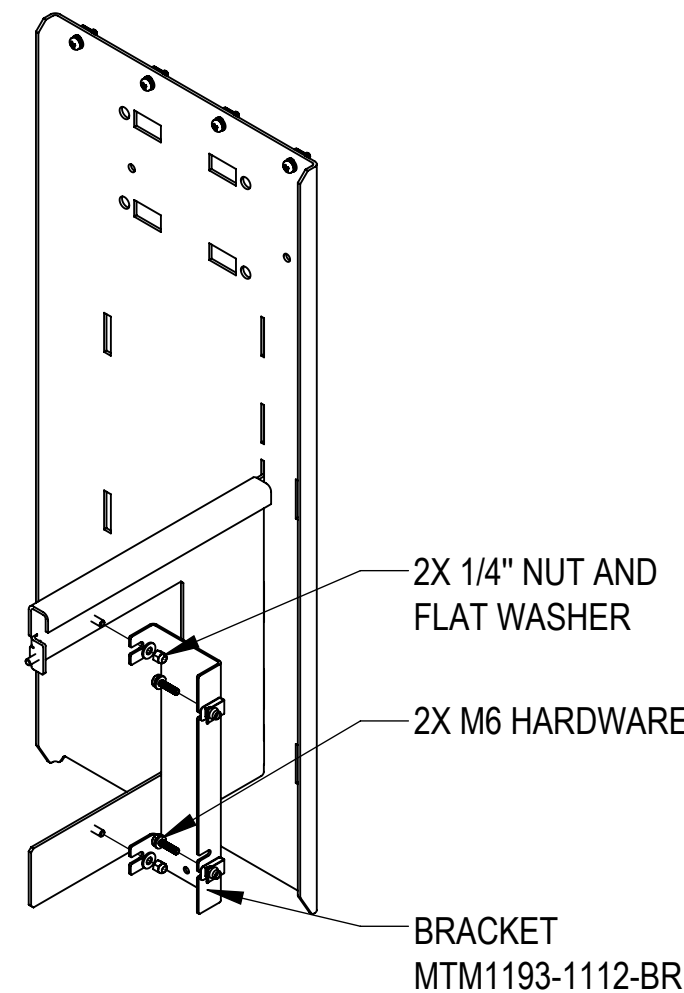
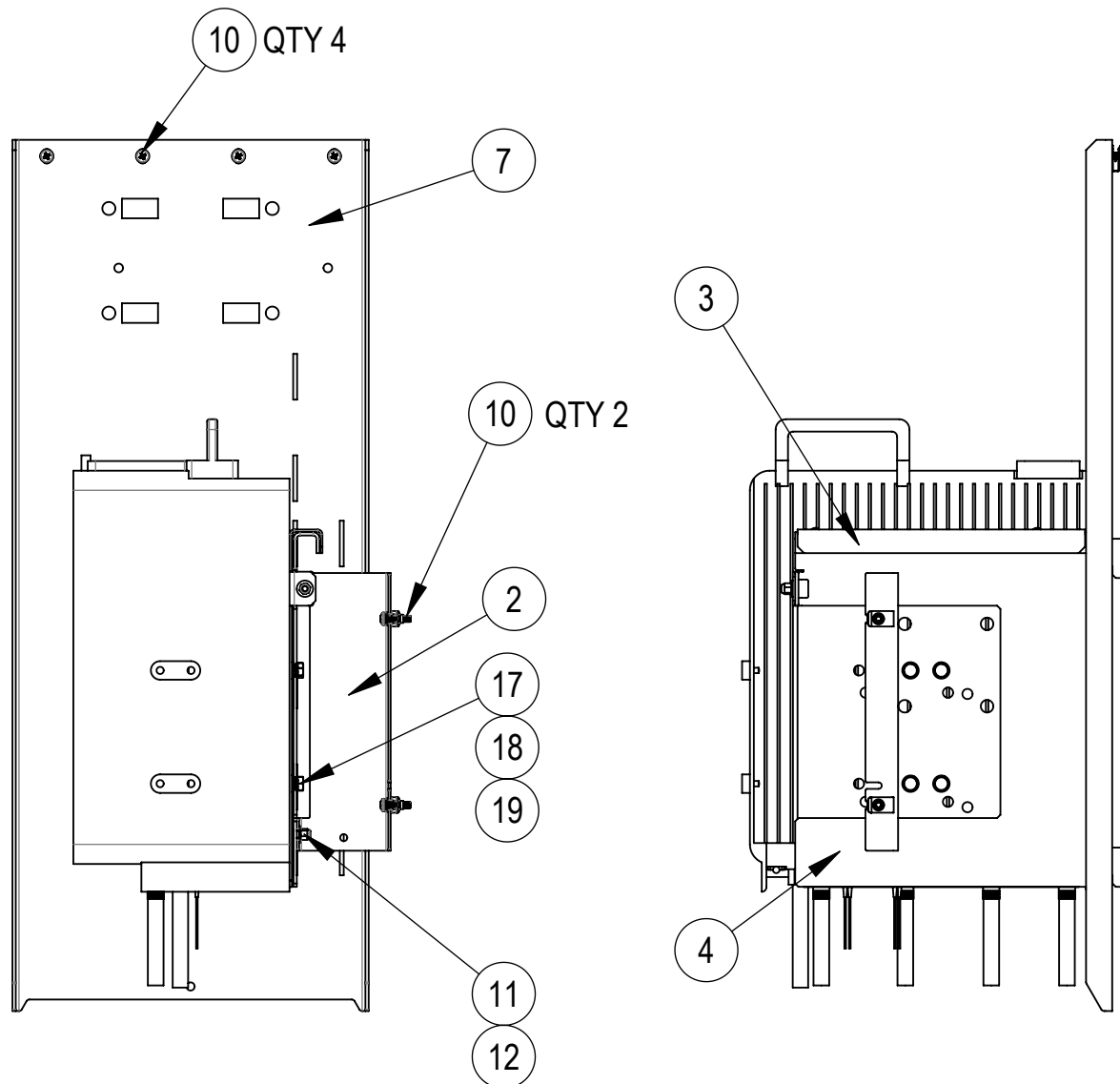

2X 1/4" NUT AND
FLAT WASHER

2X M6 HARDWARE

BRACKET
MTM1193-1112-BR

STEP 3 :
MTM1193-1112-BR

1. INSTALL ONE SIDE OF THE MOUNTING BRACKET MTM1193-1112-BR TO BRACKET OF ASSEMBLY USING 2 SETS OF M6 SEMS SCREWS, CLIP NUTS AND THE OTHER SIDE(AVOIDED SLOT) TO THE MOUNTING BRACKET MTM1160-1162-BR USING 2 SETS OF 1/4" NUTS AND FLAT WASHERS

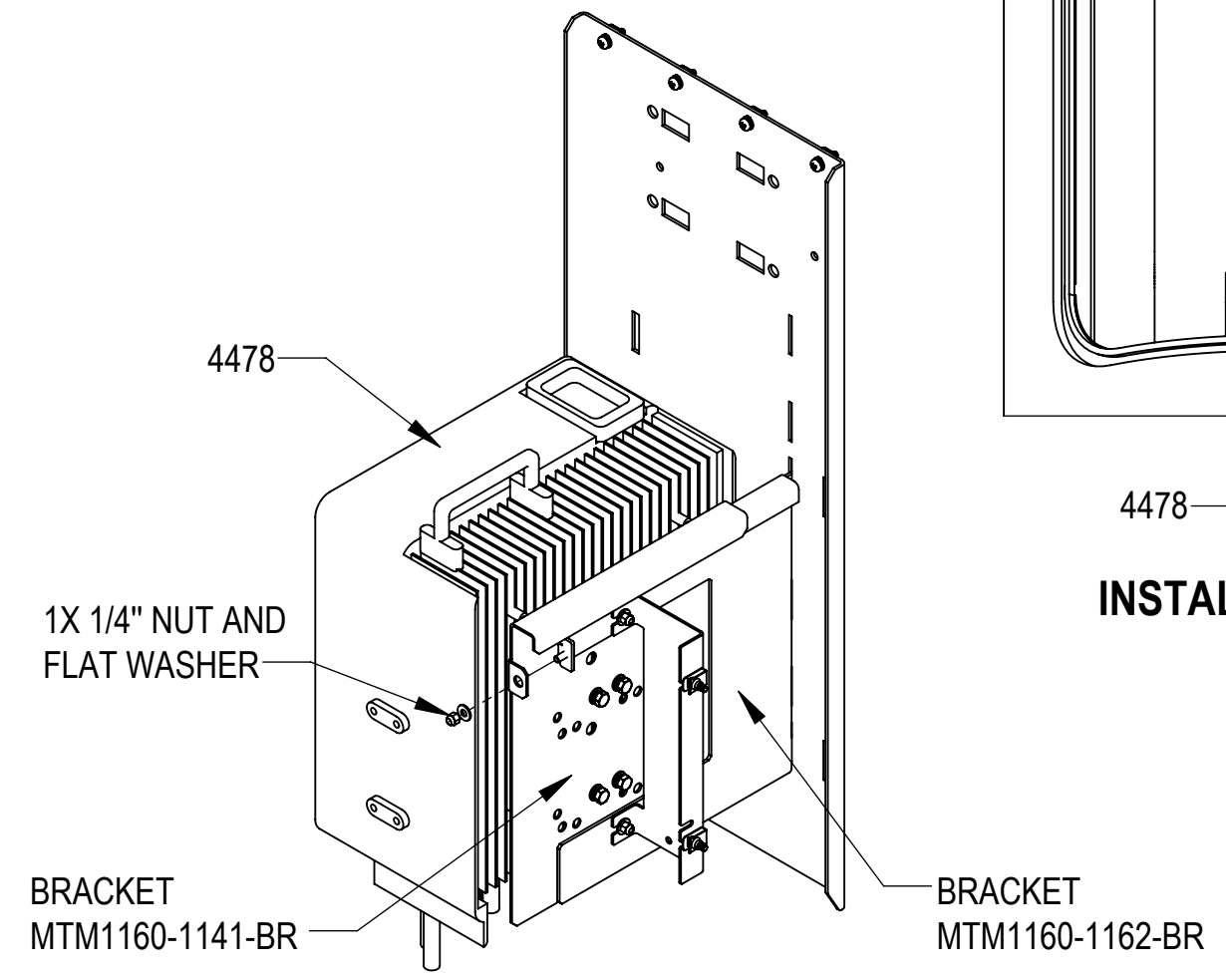

4478

1X 1/4" NUT AND
FLAT WASHER

BRACKET
MTM1160-1141-BR

BRACKET
MTM1160-1162-BR

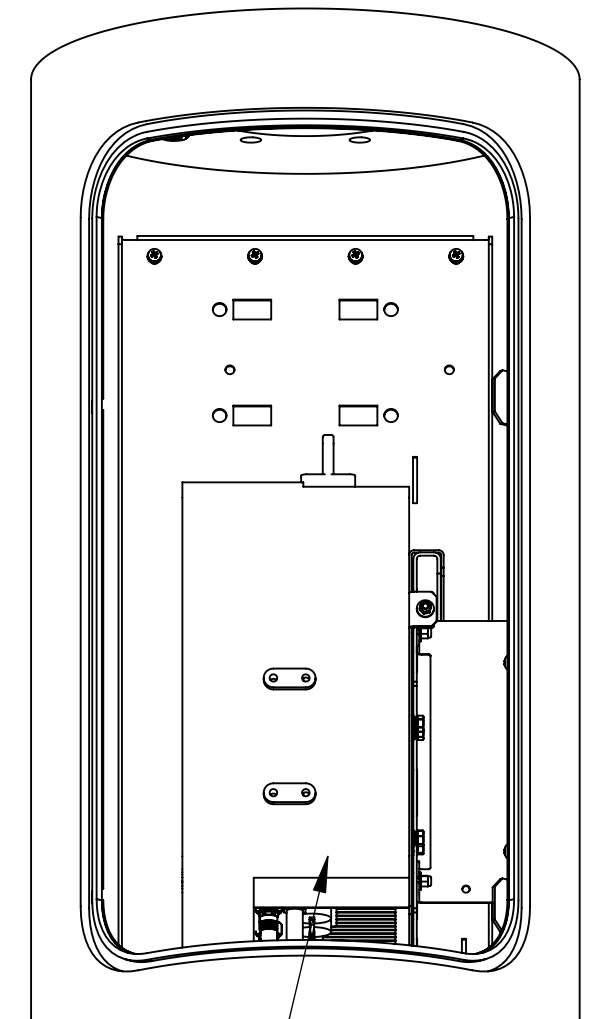

4478

INSTALLED VIEW

BOM FOR 4478 INSTALLATION

ITEM NO.	PART NUMBER	DESCRIPTION	QTY.
2	MTM1193-1112-BR	BRKT LG SPRT 4 HOOK & HANG PB20GA-0.375	1
3	MTM1160-1141-BR	BRKT SLIDE HANGER ERICSON PB20GA	1
4	MTM1160-1162-BR	BRACKET, HANGING RAIL MOVEABLE PB20GA	1
7	MTM1160-1169-BR	BRKT MAIN HK & HANG REAR PLT PB20GA	1
10	100117-4	FA,SEMS,PH,XRES,M6X25,SST,PASS	6
11	SNYL02	1/4" SS NYLOCK HEX NUT	3
12	SWF-02	FLAT WASHER, 1/4" SS	3
17	MTC9415	M8 X 25mm HEX BOLT SS	4
18	MTC9418	M8 LOCK WASHER SS	4
19	MTC9419	M8 FLAT WASHER SS	4

E7: 4478 INSTALLATION

EQUIPMENT INSTALLATION SEE SHEET 4
TORQUE ALL TO SPEC

ANDREW an Amphenol company

TITLE
KIT ERICSSON INSTALL INTO PB20GA-0.375

SIZE **C** SCALE **1:10** DOCUMENT NO.
MTM1193-1101-AMK-E

DRAWING			SHEET 12 OF 21
VERSION	STATUS	REVISION	
04	RE	E	

Confidential

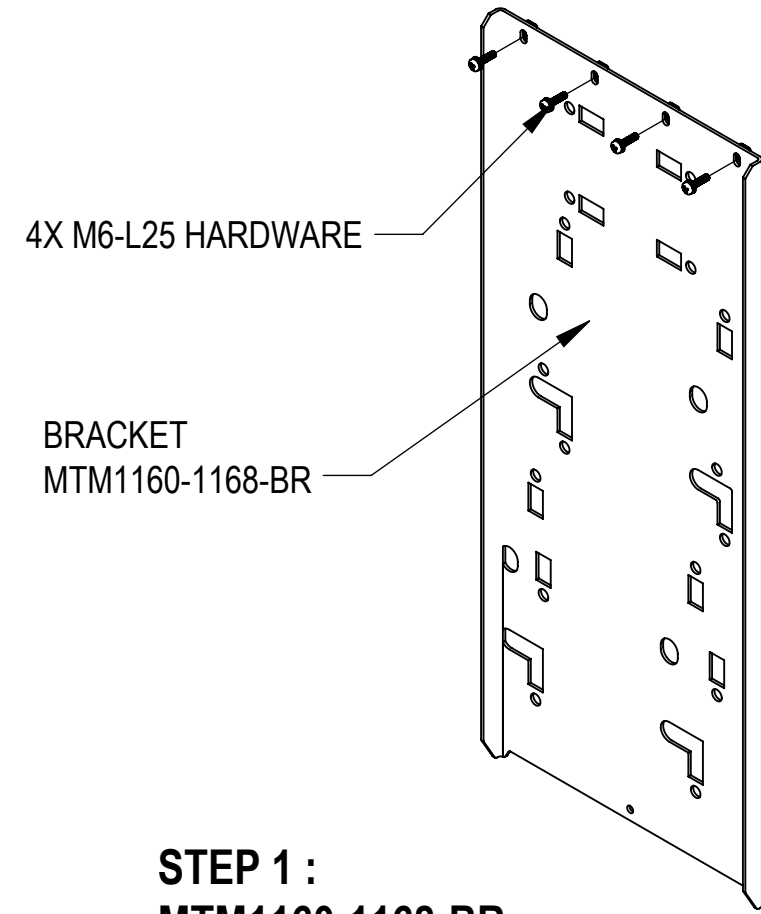
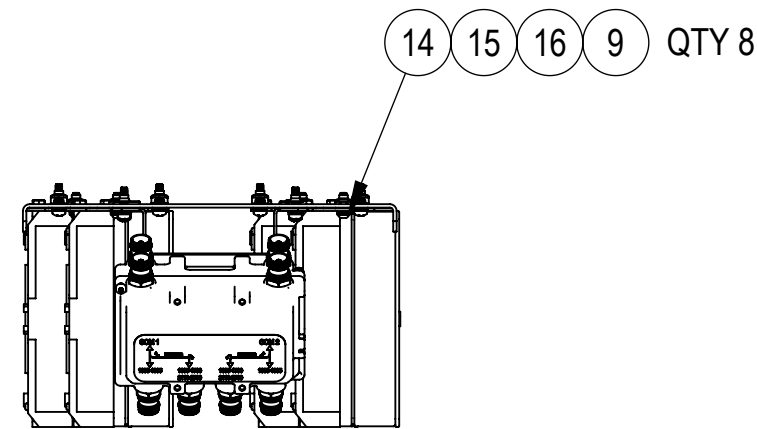

STEP 1 :
MTM1160-1168-BR

1. INSTALL THE MOUNTING BRACKET MTM1160-1168-BR TO BRACKET OF ASSEMBLY USING 4 SETS OF M6 SEMS SCREWS AND CLIP NUTS

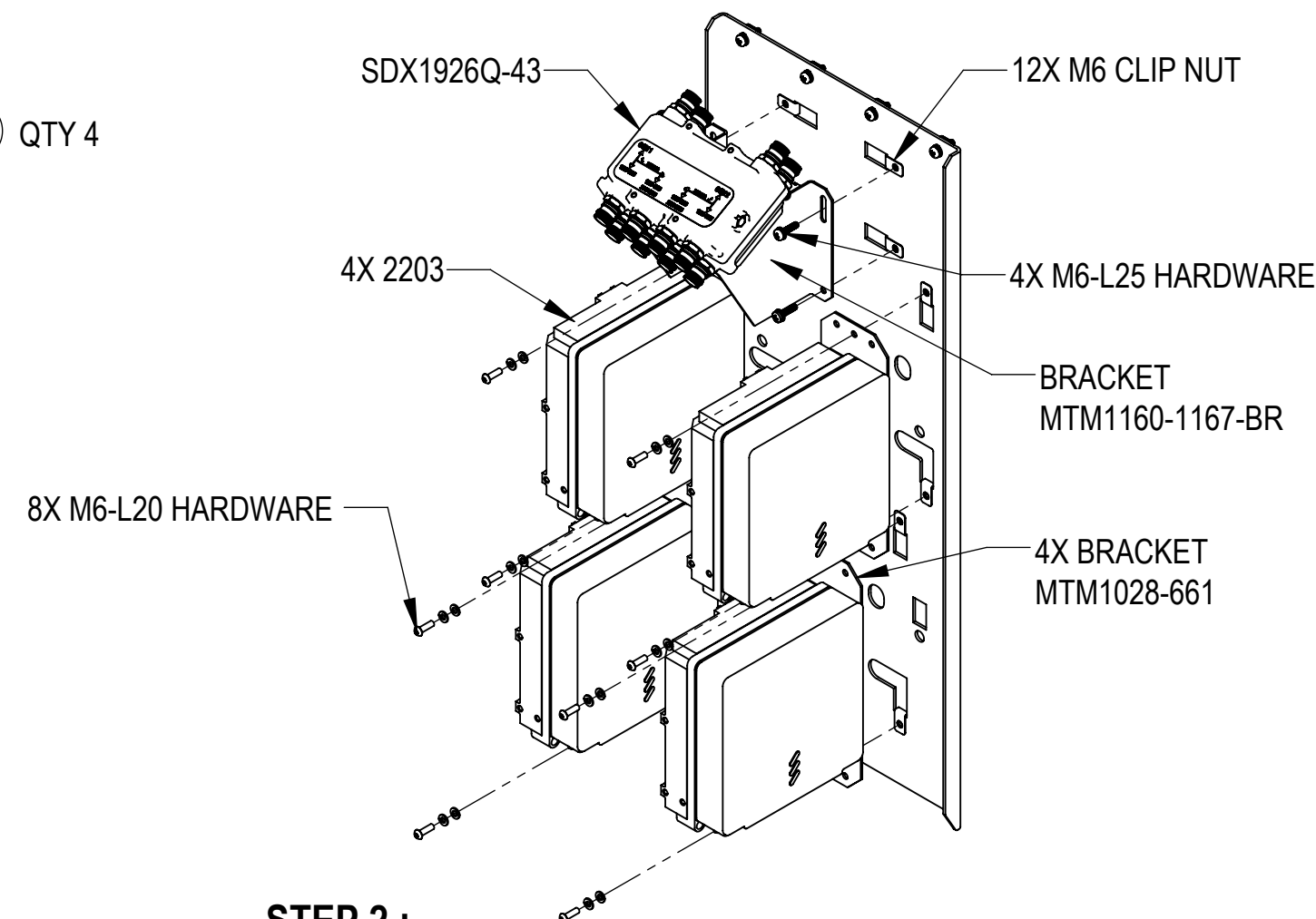
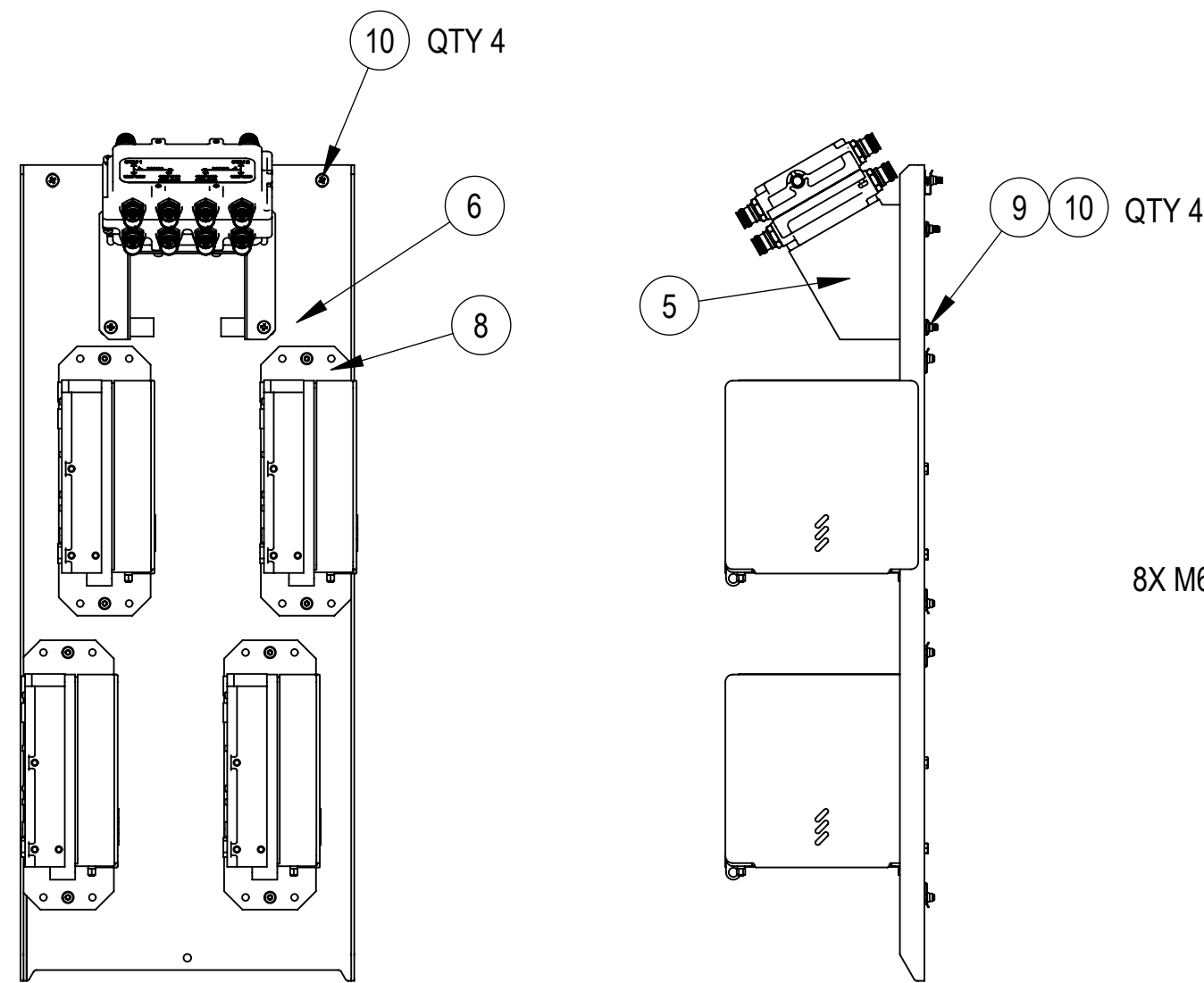

STEP 2 :
MTM1160-1167-BR (SDX1926Q-43) + 4X MTM1028-661(2203)

1. INSTALL M6 CLIP NUTS AS SHOWN
2. INSTALL THE MOUNTING BRACKET MTM1160-1167-BR TO THE MOUNTING BRACKET MTM1160-1168-BR USING 4 SETS OF M6 SEMS SCREWS AND CLIP NUTS.
3. INSTALL THE 4 MOUNTING BRACKET MTM1028-661 TO THE MOUNTING BRACKET MTM1160-1168-BR USING 8 SETS OF M6 HEX BOLTS, LOCK WASHERS AND FLAT WASHERS

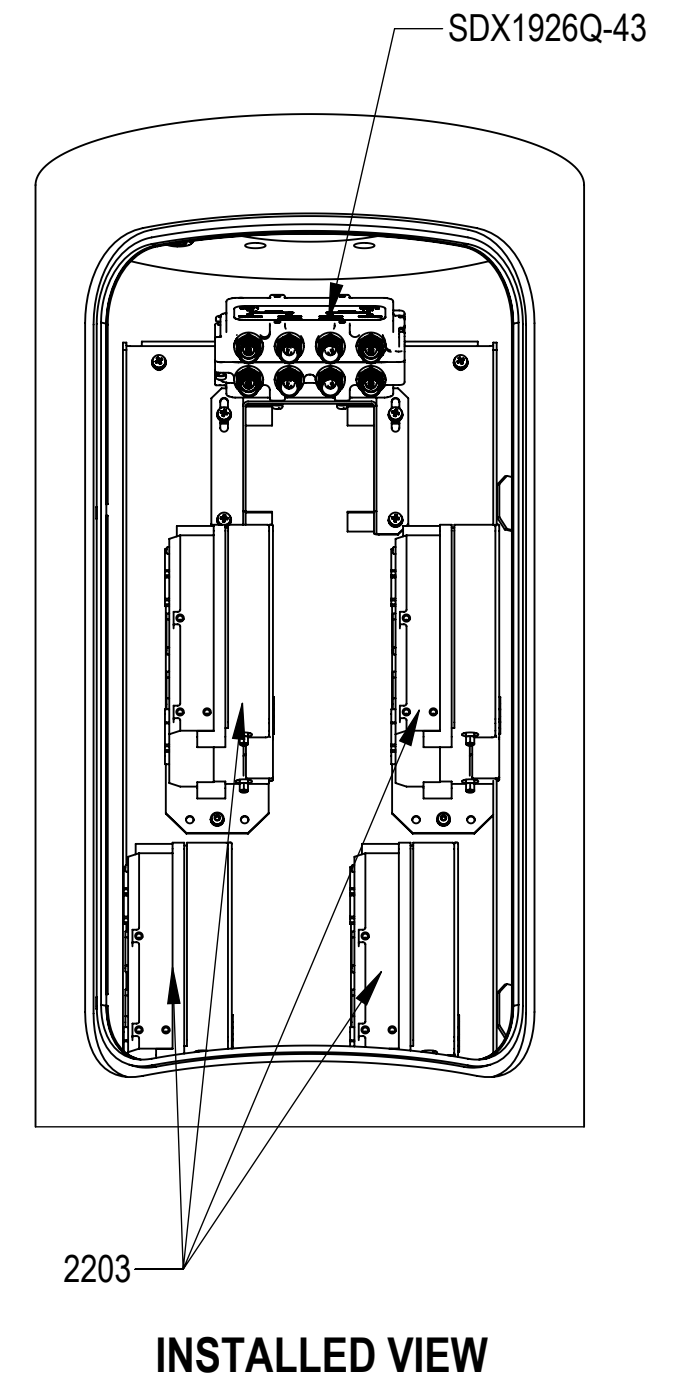

BOM FOR 4X 2203 + QUAD DIPLEXER SDX1926Q-43 INSTALLATION

ITEM NO.	PART NUMBER	DESCRIPTION	QTY.
5	MTM1160-1167-BR	BRKT DIPLEX MNTG TOP/ANGLE PB20GA	1
6	MTM1160-1168-BR	BRKT MAIN PLATE RADIOS REAR PB20GA	1
8	MTM1028-661-BR	BRACKET, ERC2203 RADIO	4
9	460143456	CLIP NUT, M6, 316 SST	12
10	100117-4	FA,SEMS,PH,XRES,M6X25,SST,PASS	8
13	460155492	SEMS, HCS M6 X 16MM WITH CAPTIVE WASHERS	12
14	100560-66	SCR,BUTTN HD,HEXSOCK,M6X20,SST,PASS	8
15	100522-25	WSHR,LK,SPLT, M6,SST, PASS	8
16	100521-25	WSHR,FLAT,M6,6.4X12X1.6,SST,PASS	8

E8: 4X 2203 + QUAD DIPLEXER SDX1926Q-43 INSTALLATION

EQUIPMENT INSTALLATION SEE SHEET 5
TORQUE ALL TO SPEC

ANDREW an Amphenol company

TITLE
KIT ERICSSON INSTALL INTO PB20GA-0.375

SIZE C	SCALE 1:10	DOCUMENT NO. MTM1193-1101-AMK-E
DRAWING		SHEET
VERSION 04	STATUS RE	REVISION E

13 OF 21

Confidential

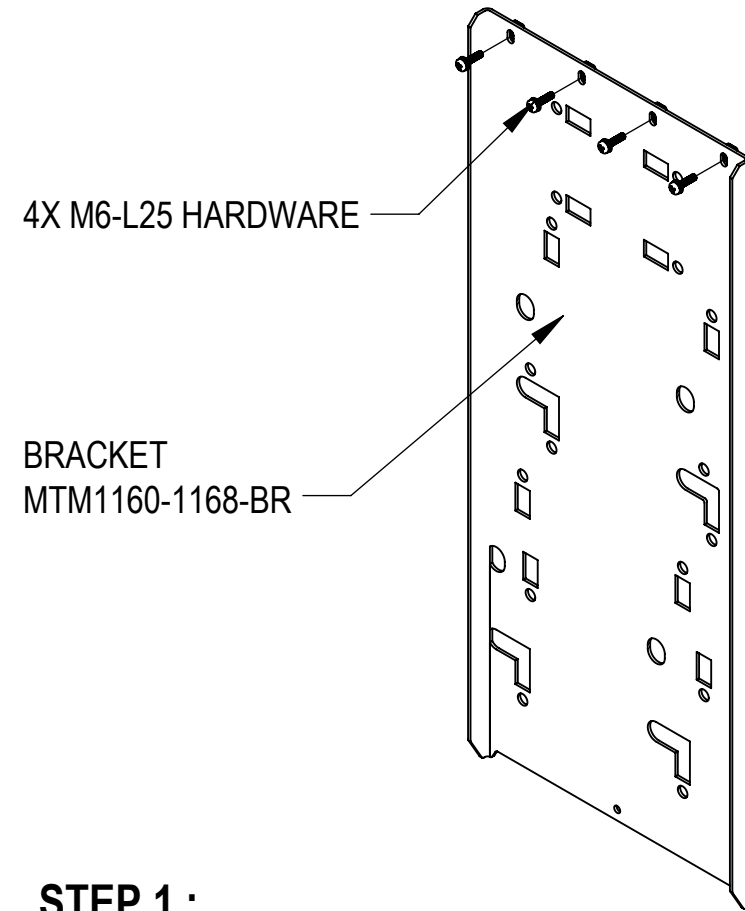
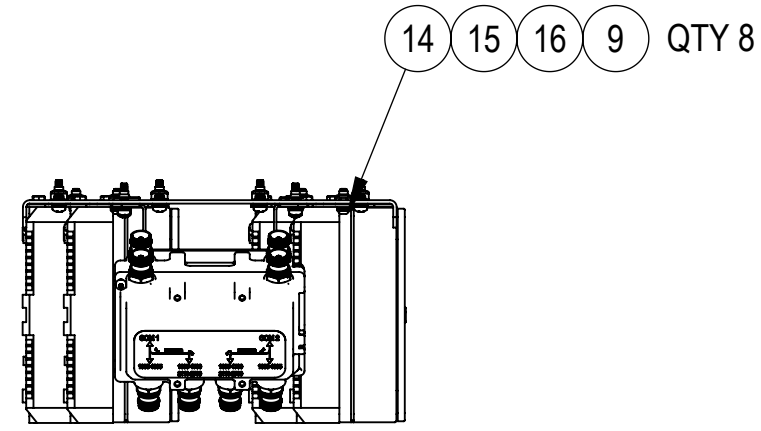

STEP 1 :
MTM1160-1168-BR

1. INSTALL THE MOUNTING BRACKET MTM1160-1168-BR TO BRACKET OF ASSEMBLY USING 4 SETS OF M6 SEMS SCREWS AND CLIP NUTS

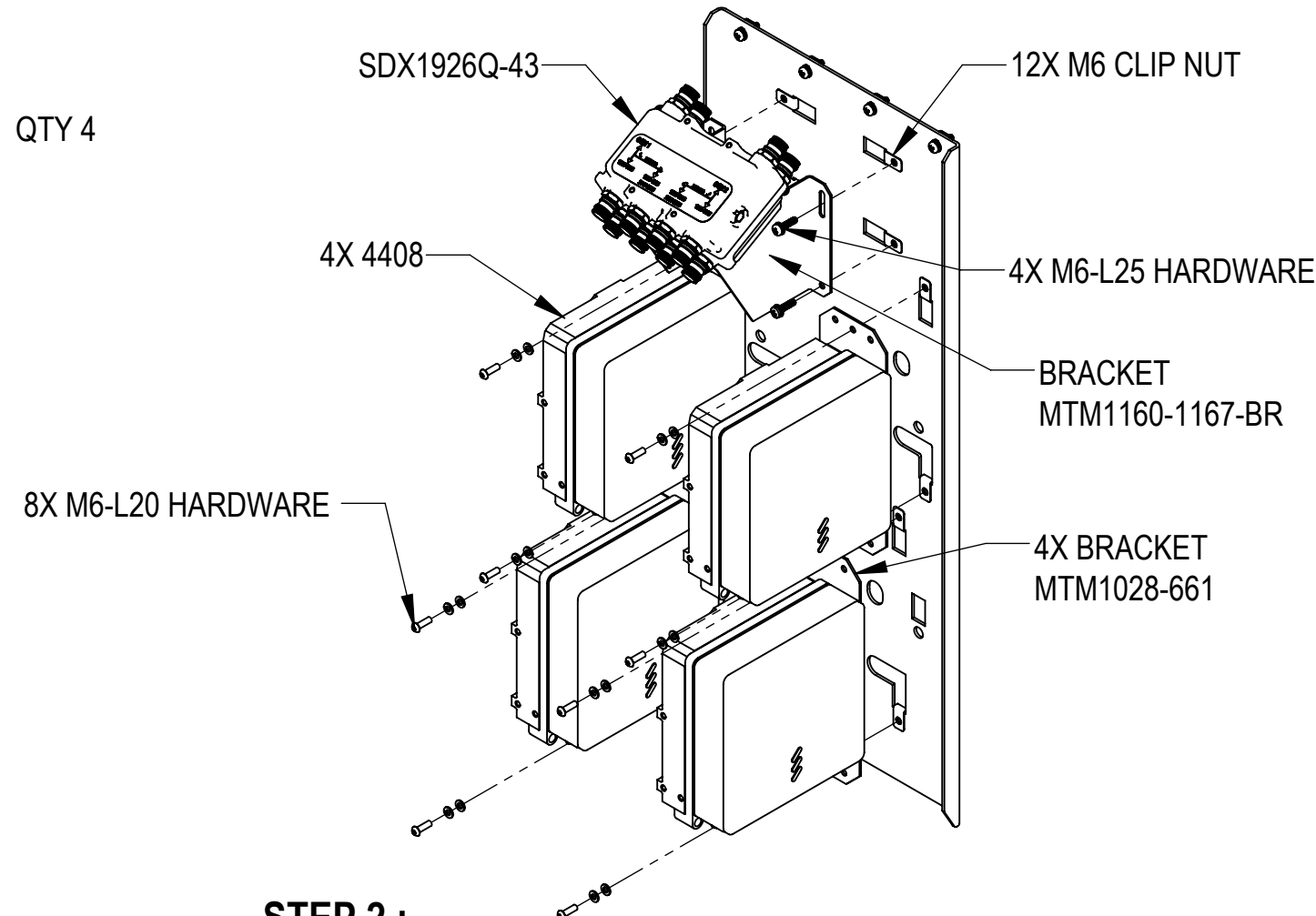
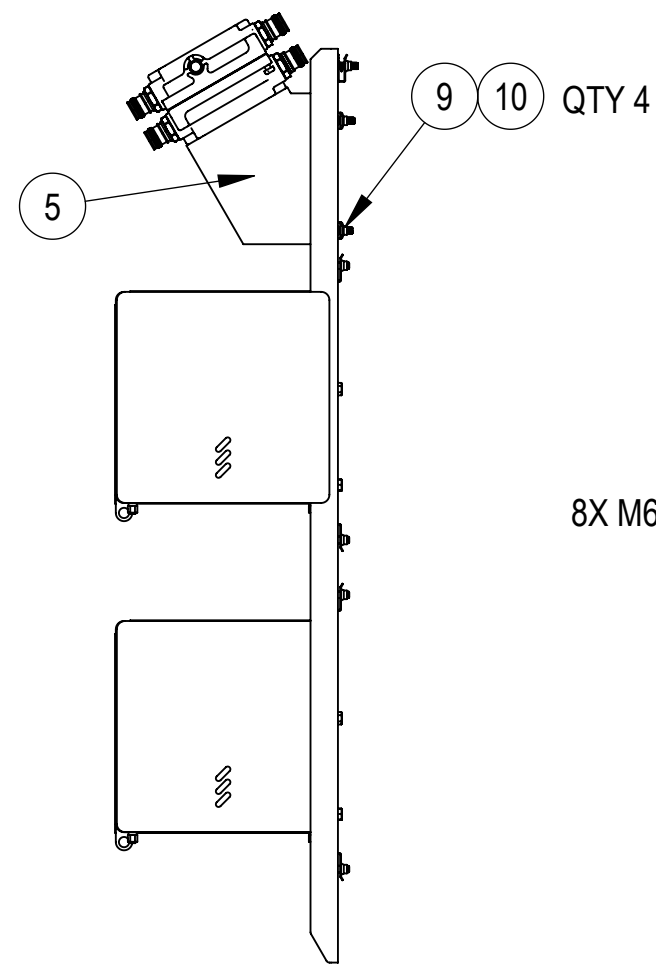
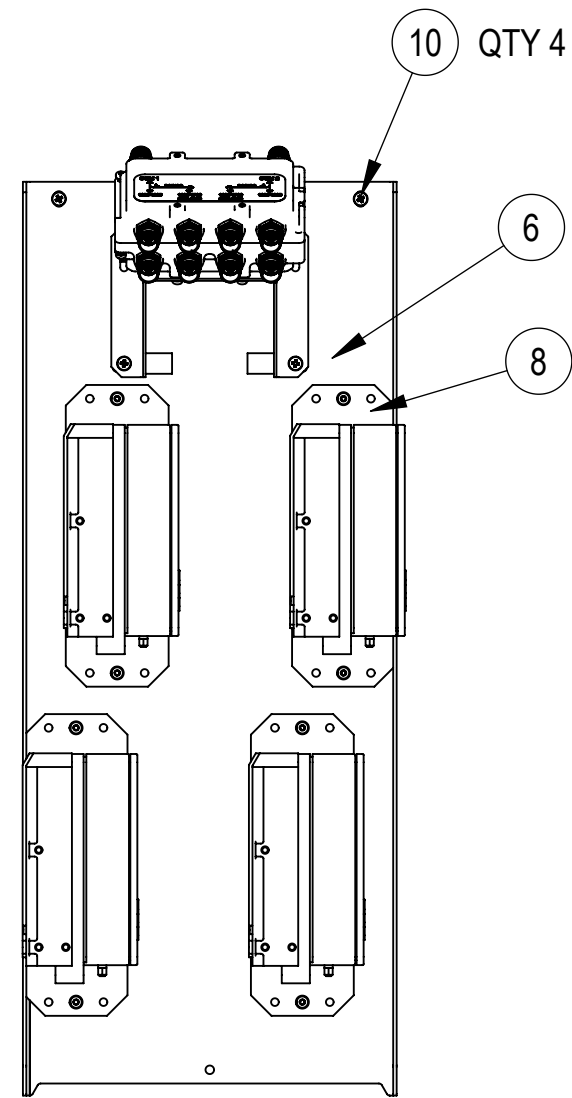

STEP 2 :
MTM1160-1167-BR (SDX1926Q-43) + 4X MTM1028-661(4408)

1. INSTALL M6 CLIP NUTS AS SHOWN
2. INSTALL THE MOUNTING BRACKET MTM1160-1167-BR TO THE MOUNTING BRACKET MTM1160-1168-BR USING 4 SETS OF M6 SEMS SCREWS AND CLIP NUTS.
3. INSTALL THE 4 MOUNTING BRACKET MTM1028-661 TO THE MOUNTING BRACKET MTM1160-1168-BR USING 8 SETS OF M6 HEX BOLTS, LOCK WASHERS AND FLAT WASHERS

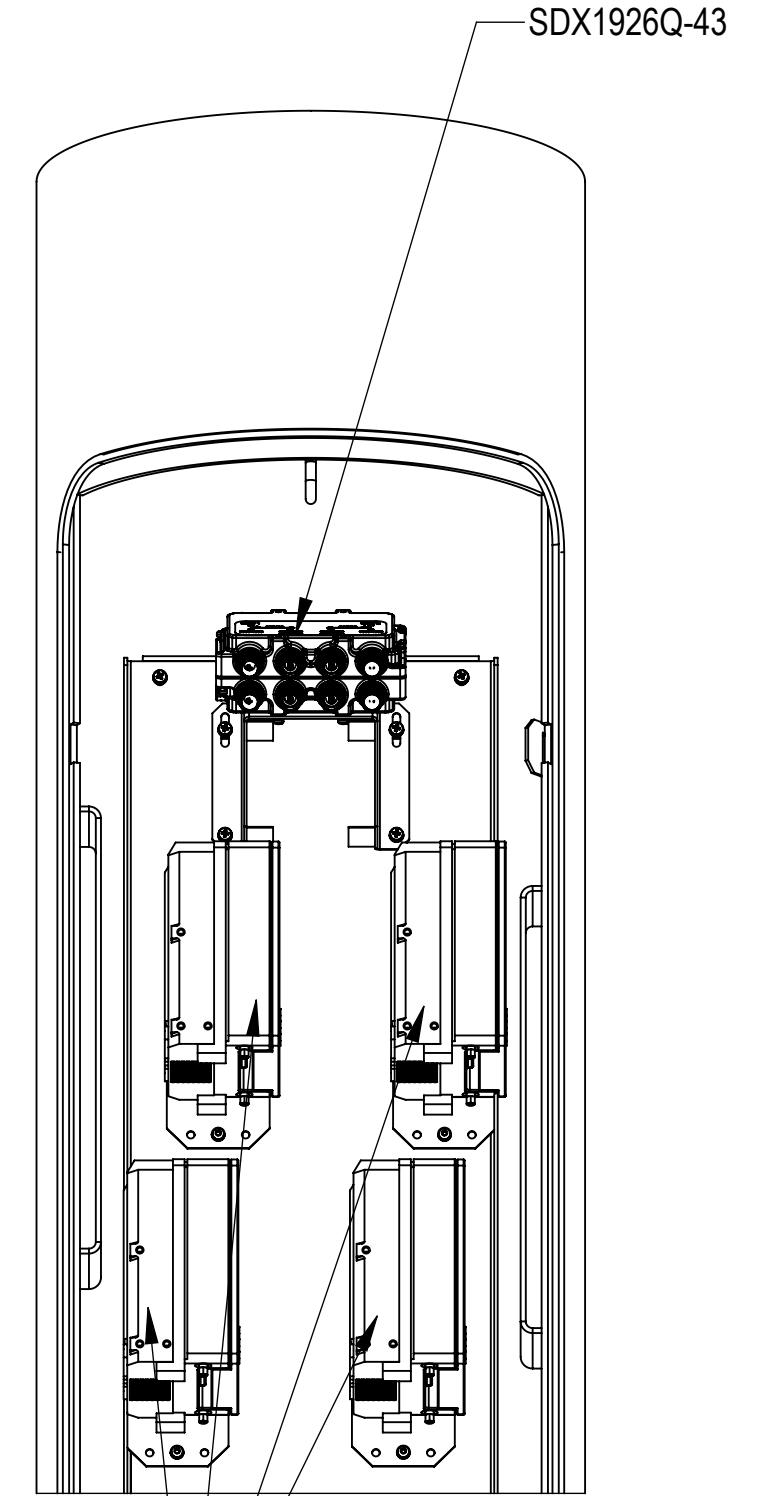

4408
INSTALLED VIEW

BOM FOR 4X 4408 + QUAD DIPLEXER SDX1926Q-43 INSTALLATION

ITEM NO.	PART NUMBER	DESCRIPTION	QTY.
5	MTM1160-1167-BR	BRKT DIPLEX MNTG TOP/ANGLE PB20GA	1
6	MTM1160-1168-BR	BRKT MAIN PLATE RADIOS REAR PB20GA	1
8	MTM1028-661-BR	BRACKET, ERC2203 RADIO	4
9	460143456	CLIP NUT, M6, 316 SST	12
10	100117-4	FA,SEMS,PH,XRES,M6X25,SST,PASS	8
13	460155492	SEMS, HCS M6 X 16MM WITH CAPTIVE WASHERS	12
14	100560-66	SCR,BUTTN HD,HEXSOCK,M6X20,SST,PASS	8
15	100522-25	WSHR,LK,SPLT, M6,SST, PASS	8
16	100521-25	WSHR,FLAT,M6,6.4X12X1.6,SST,PASS	8

E9(IP20): 4X 4408 + QUAD DIPLEXER SDX1926Q-43 INSTALLATION

EQUIPMENT INSTALLATION SEE SHEET 5
TORQUE ALL TO SPEC



TITLE
KIT ERICSSON INSTALL INTO PB20GA-0.375

SIZE C	SCALE 1:10	DOCUMENT NO. MTM1193-1101-AMK-E
DRAWING		SHEET
VERSION 04	STATUS RE	REVISION E
		14 OF 21

Confidential

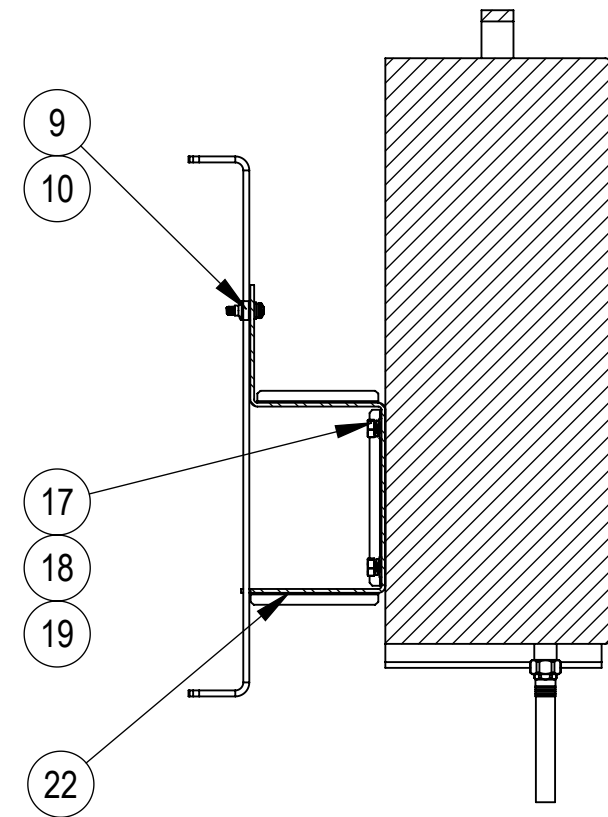
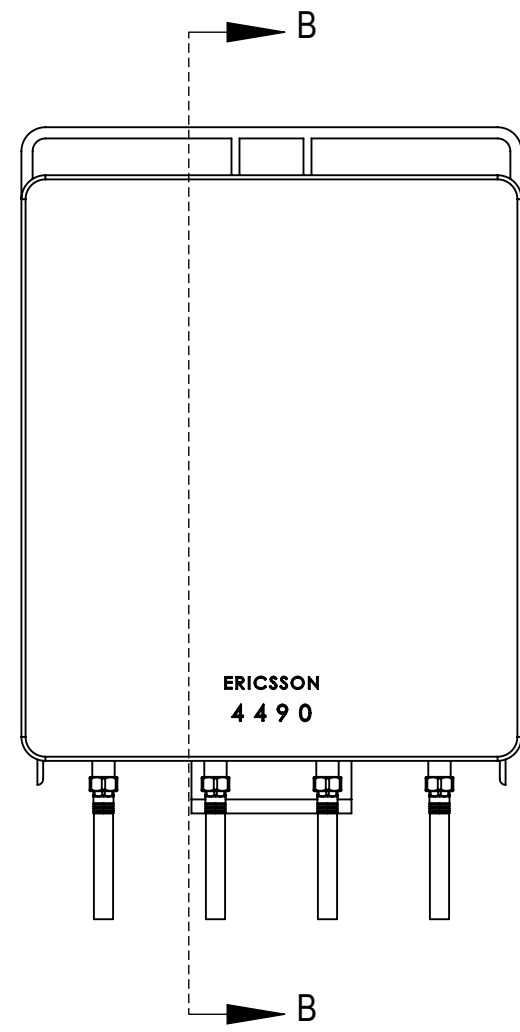
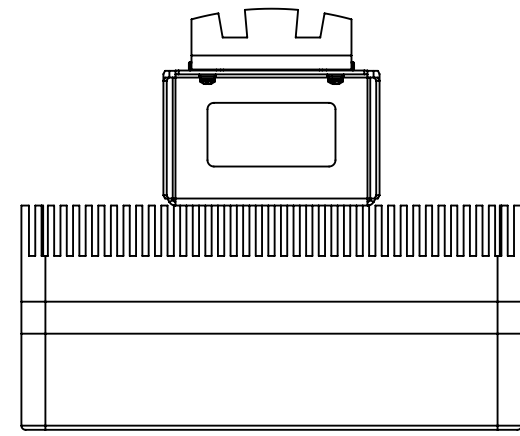

SECTION B-B
SCALE 1 : 6

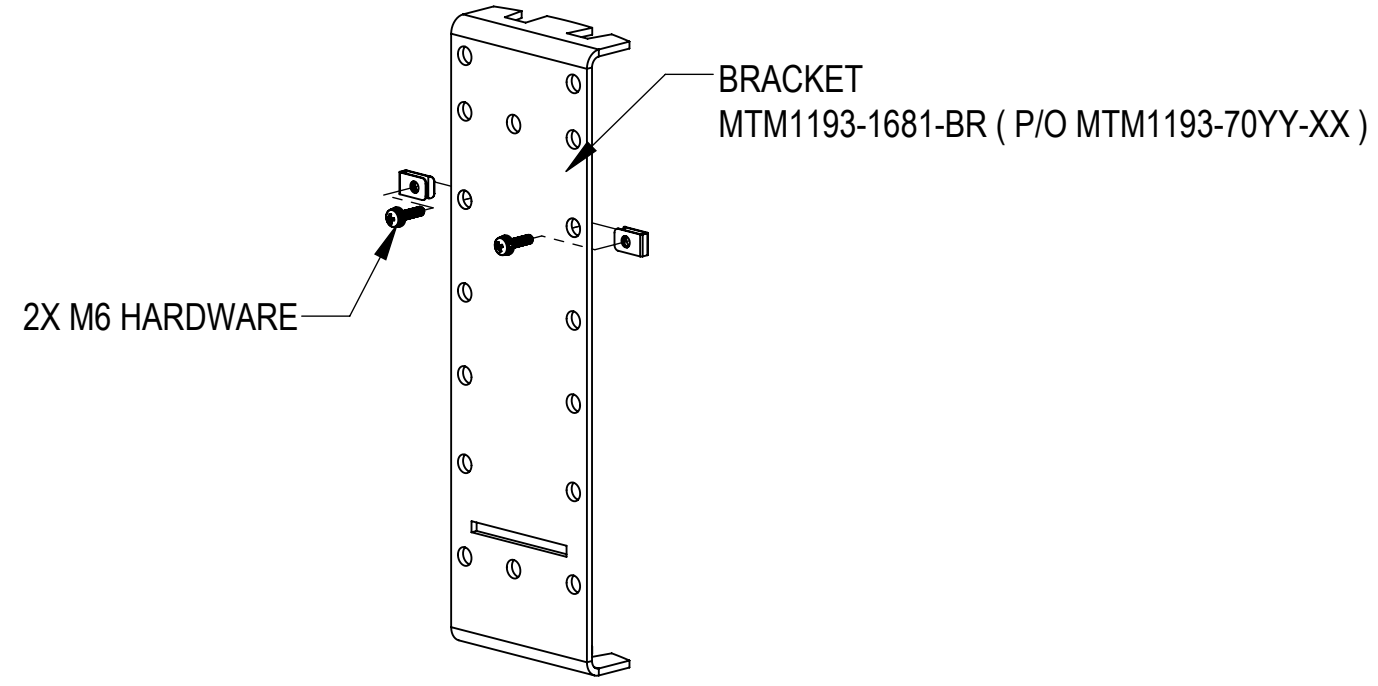

STEP 1 :
MTM1193-1681-BR (IN IP20)
1. PRE-INSTALL 2 SETS OF M6 SEMS SCREWS AND CLIP NUTS TO THE BRACKET MTM1193-1681-BR OF THE IP20

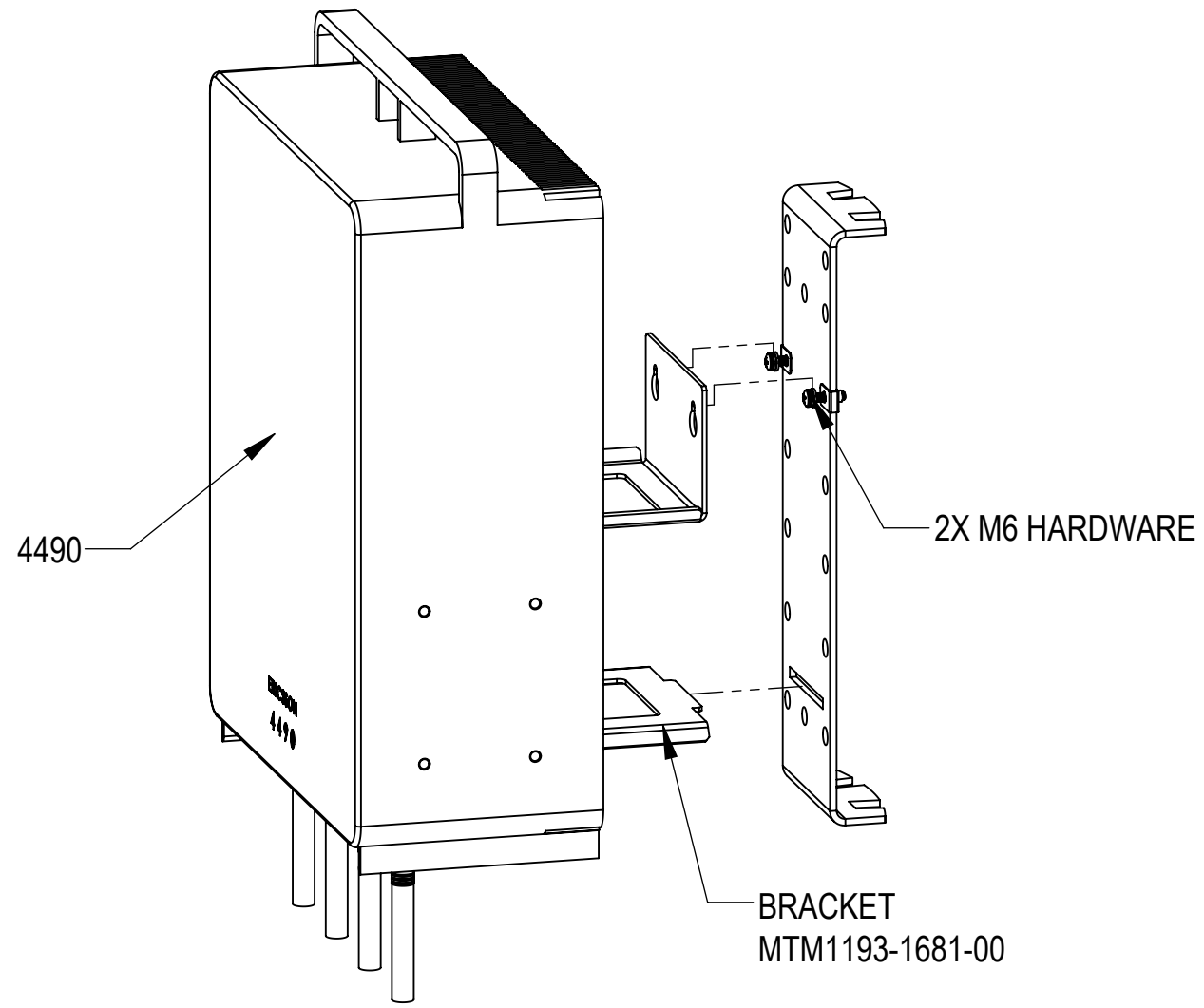

STEP 2 :
MTM1193-1681-00(4490)
1. HANG THE 4490-ASSEMBLY TO THE BRACKET MTM1193-1681-BR OF THE IP20
2. FIX THE 4490-ASSEMBLY TO THE BRACKET OF THE IP20 USING 2 SETS OF M6 BOLTS AND CLIP NUTS

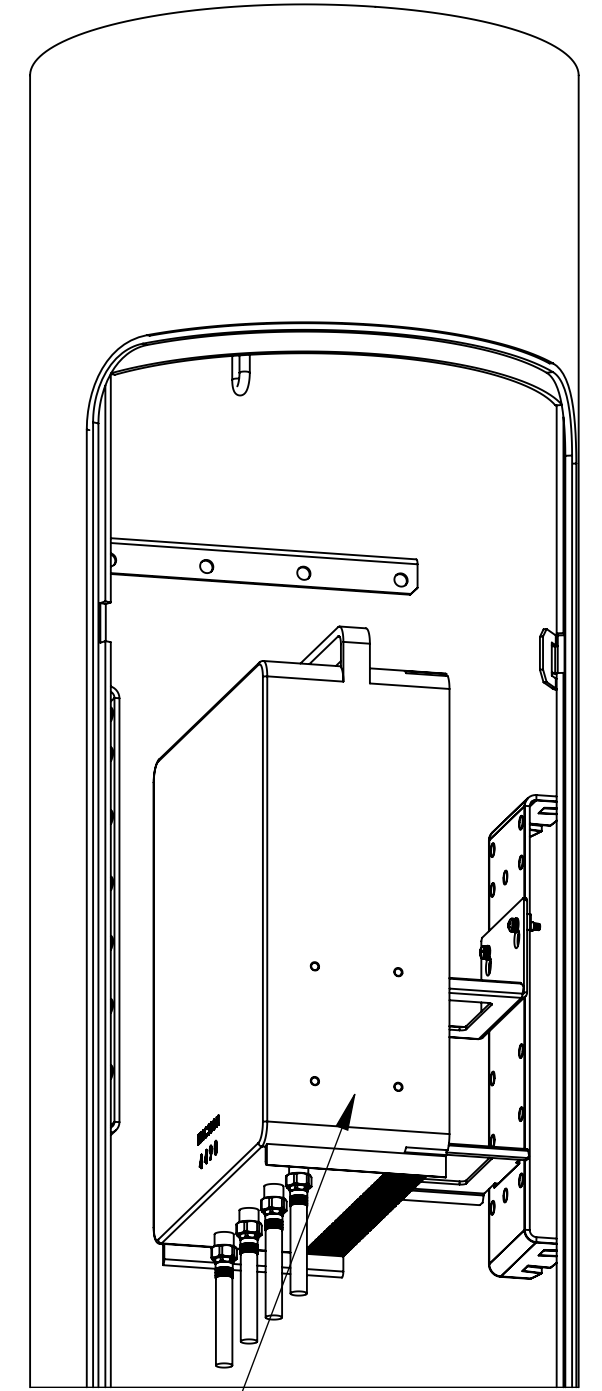

INSTALLED VIEW

BOM FOR 4490 INSTALLATION

ITEM NO.	PART NUMBER	DESCRIPTION	QTY.
9	460143456	CLIP NUT, M6, 316 SST	2
10	100117-4	FA,SEMS,PH,XRES,M6X25,SST,PASS	2
17	MTC9415	M8 X 25mm HEX BOLT SS	4
18	MTC9418	M8 LOCK WASHER SS	4
19	MTC9419	M8 FLAT WASHER SS	4
22	MTM1193-1681-00	BRKT MOUNT RU4890 AND 4490	1

E10 (IP20): 4490 INSTALLATION

EQUIPMENT INSTALLATION SEE SHEET 4
TORQUE ALL TO SPEC



TITLE KIT ERICSSON INSTALL INTO PB20GA-0.375				
SIZE C	SCALE 1:8	DOCUMENT NO. MTM1193-1101-AMK-E		
DRAWING		VERSION	STATUS	REVISION
SHEET		04	RE	E
				SHEET 15 OF 21

Confidential

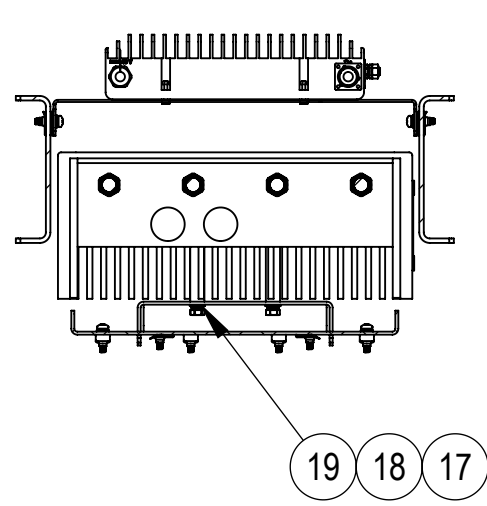

SECTION A-A
SCALE 1 : 8

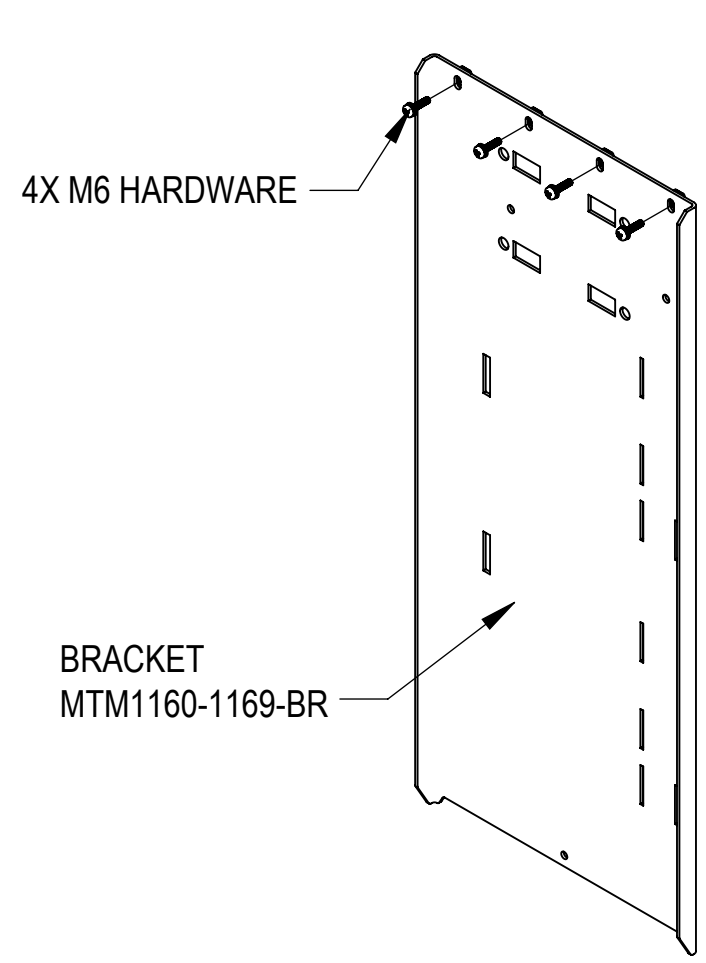

BRACKET
MTM1160-1169-BR

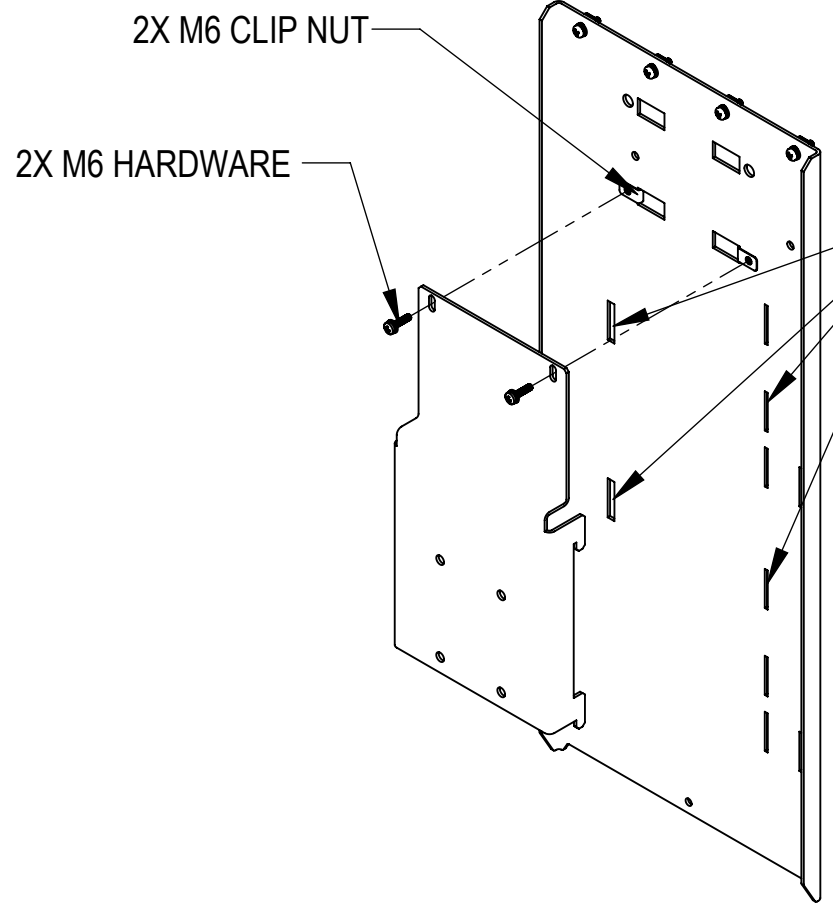

THE INSTALLATION POSITIONS ARE THE 3RD AND 5TH HOLES FROM BRACKET THE BOTTOM AND THE 2 HOLES FROM THE THIRD COLUMN

**STEP 1 :
MTM1160-1169-BR**

1. INSTALL THE MOUNTING BRACKET MTM1160-1169-BR TO BRACKET OF ASSEMBLY USING 4 SETS OF M6 SEMS SCREWS AND CLIP NUTS

**STEP 2 :
MTM1209-1000-BR (4467 NO SHOW)**

1. INSTALL M6 CLIP NUTS AS SHOWN
2. HANG THE MOUNTING BRACKET MTM1209-1000-BR TO THE 3RD AND 5TH HOLES FROM BRACKET THE BOTTOM AND THE 2 HOLES FROM THE THIRD COLUMN OF THE MOUNTING BRACKET MTM1160-1169-BR (4467 NO SHOW)
3. INSTALL THE MOUNTING BRACKET MTM1209-1000-BR TO BRACKET OF ASSEMBLY USING 2 SETS OF M6 SEMS SCREWS AND CLIP NUTS

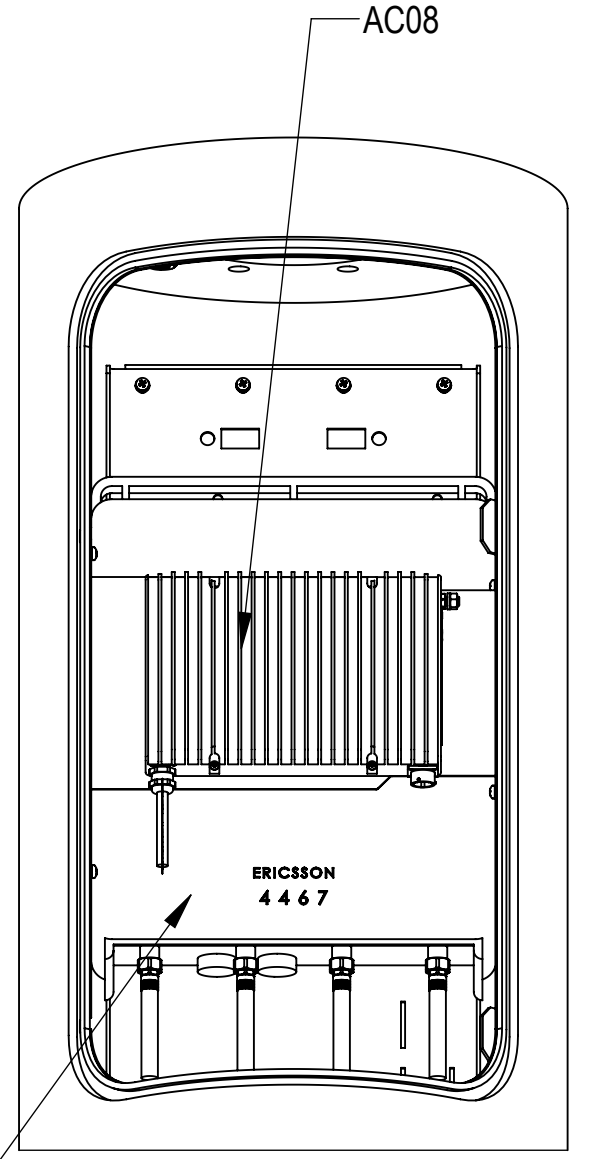

INSTALLED VIEW

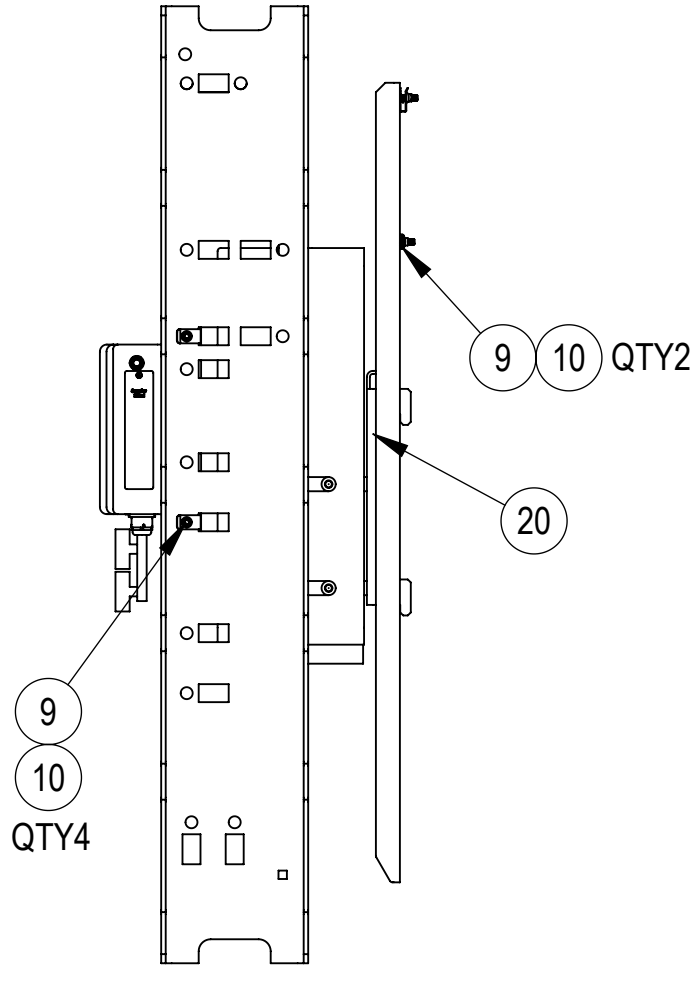
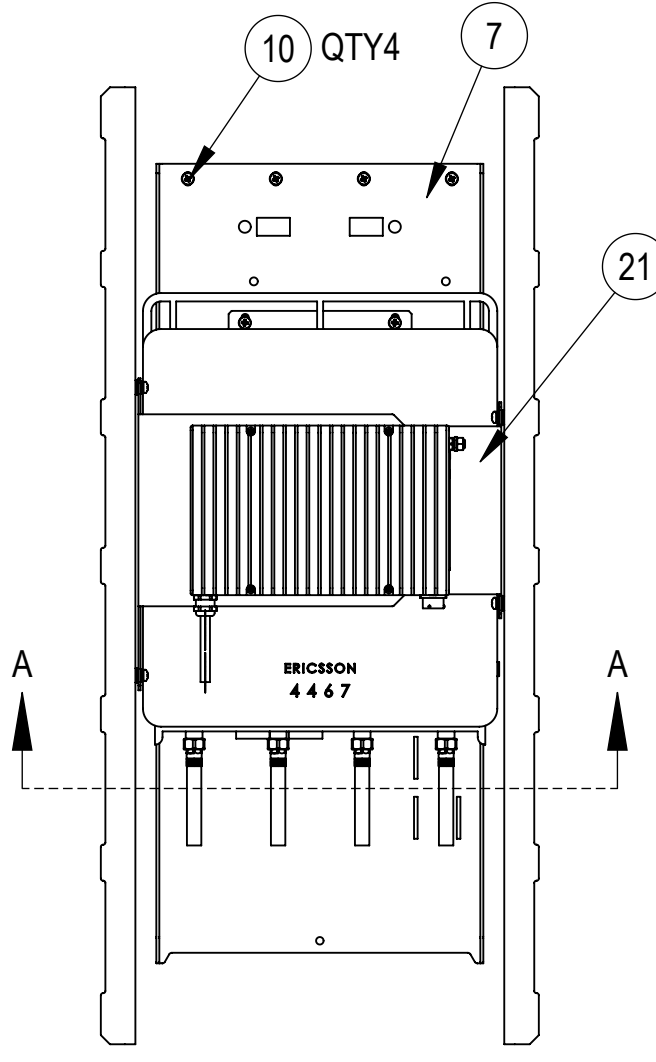

BRACKET
MTM1160-8842
(IN D-MODULE)

4X M6 HARDWARE

AC08

BRACKET
MTM1160-8841
(IN D-MODULE)

4X M6 CLIP NUT

**STEP 3 :
MTM1209-2000-BR (AC08)**

1. INSTALL THE MOUNTING BRACKET MTM1209-2000-BR TO BRACKET OF ASSEMBLY(D-MODULE) USING 4 SETS OF M6 SEMS SCREWS AND CLIP NUTS

E11 (PB20 AND D-MODULE): 4467 + AC08 INSTALLATION

EQUIPMENT INSTALLATION SEE SHEET 5
TORQUE ALL TO SPEC

BOM FOR 4467 + AC08 INSTALLATION

ITEM NO.	PART NUMBER	DESCRIPTION	QTY.
7	MTM1160-1169-BR	BRKT MAIN HK & HANG REAR PLT PB20GA	1
9	460143456	CLIP NUT, M6, 316 SST	6
10	100117-4	FA,SEMS,PH,XRES,M6X25,SST,PASS	10
17	MTC9415	M8 X 25mm HEX BOLT SS	4
18	MTC9418	M8 LOCK WASHER SS	4
19	MTC9419	M8 FLAT WASHER SS	4
20	MTM1209-1000-BR	BRKT MOUNT RU4467	1
21	MTM1209-2000-BR	BRKT MOUNT AC08	1



TITLE
KIT ERICSSON INSTALL INTO PB20GA-0.375

SIZE C	SCALE 1:10	DOCUMENT NO. MTM1193-1101-AMK-E		
DRAWING		VERSION	STATUS	REVISION
		04	RE	E
				SHEET 16 OF 21

Confidential

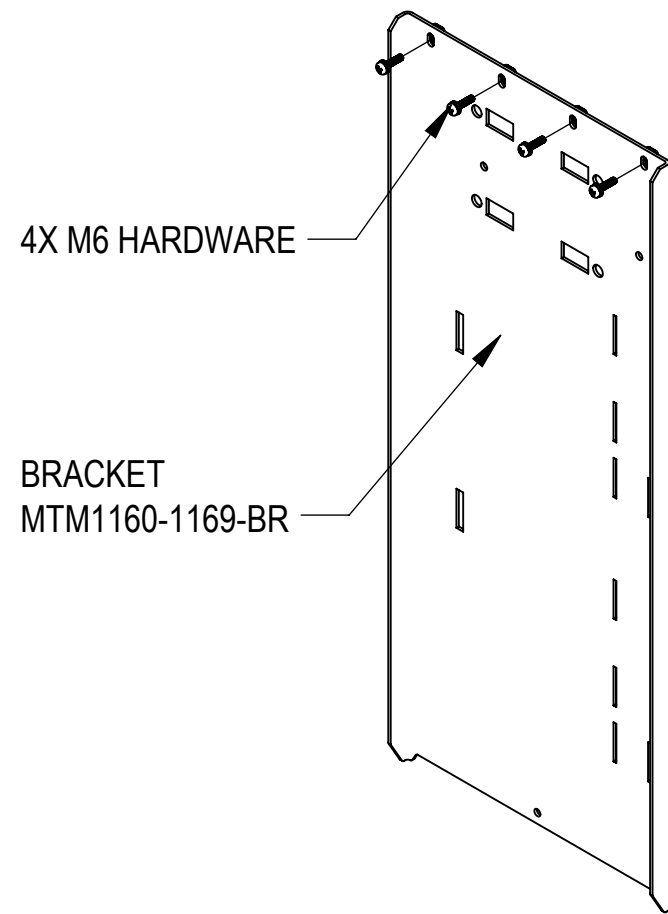
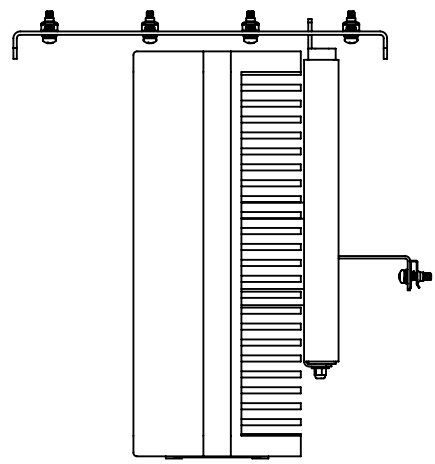

STEP 1 :
MTM1160-1169-BR
1. INSTALL THE MOUNTING BRACKET MTM1160-1169-BR TO BRACKET OF ASSEMBLY USING 4 SETS OF M6 SEMS SCREWS AND CLIP NUTS

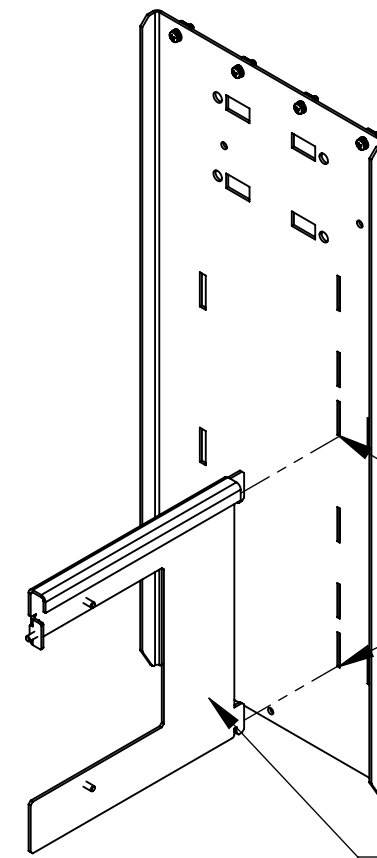

STEP 2 :
MTM1160-1162-BR
1. HANG THE MOUNTING BRACKET MTM1160-1162-BR TO THE 2ND AND 5TH HOLES FROM THE BOTTOM OF THE MOUNTING BRACKET MTM1160-1169-BR

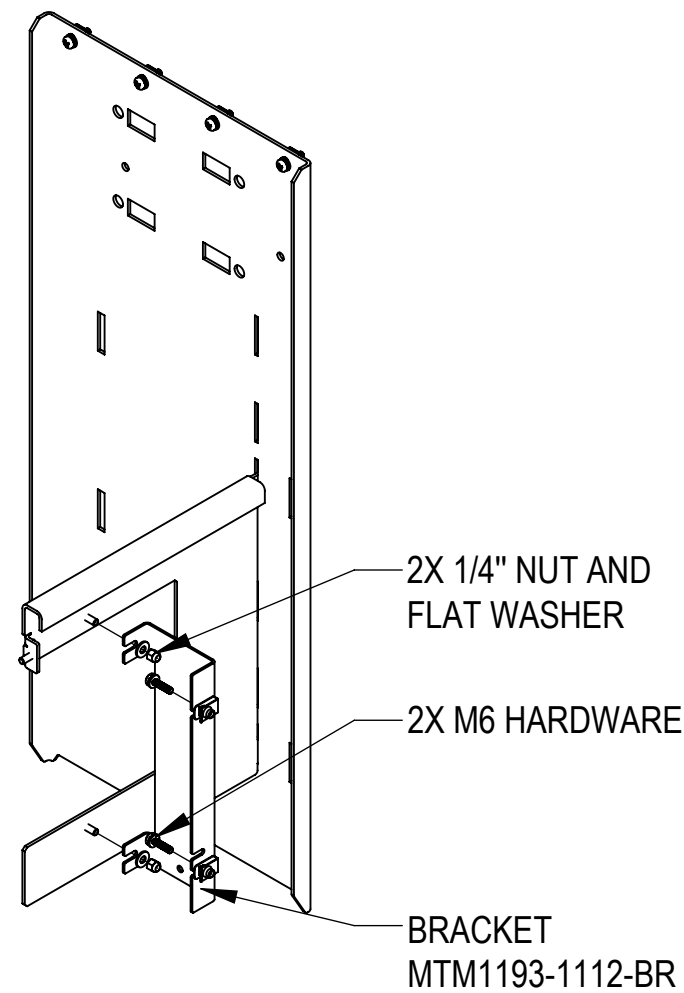
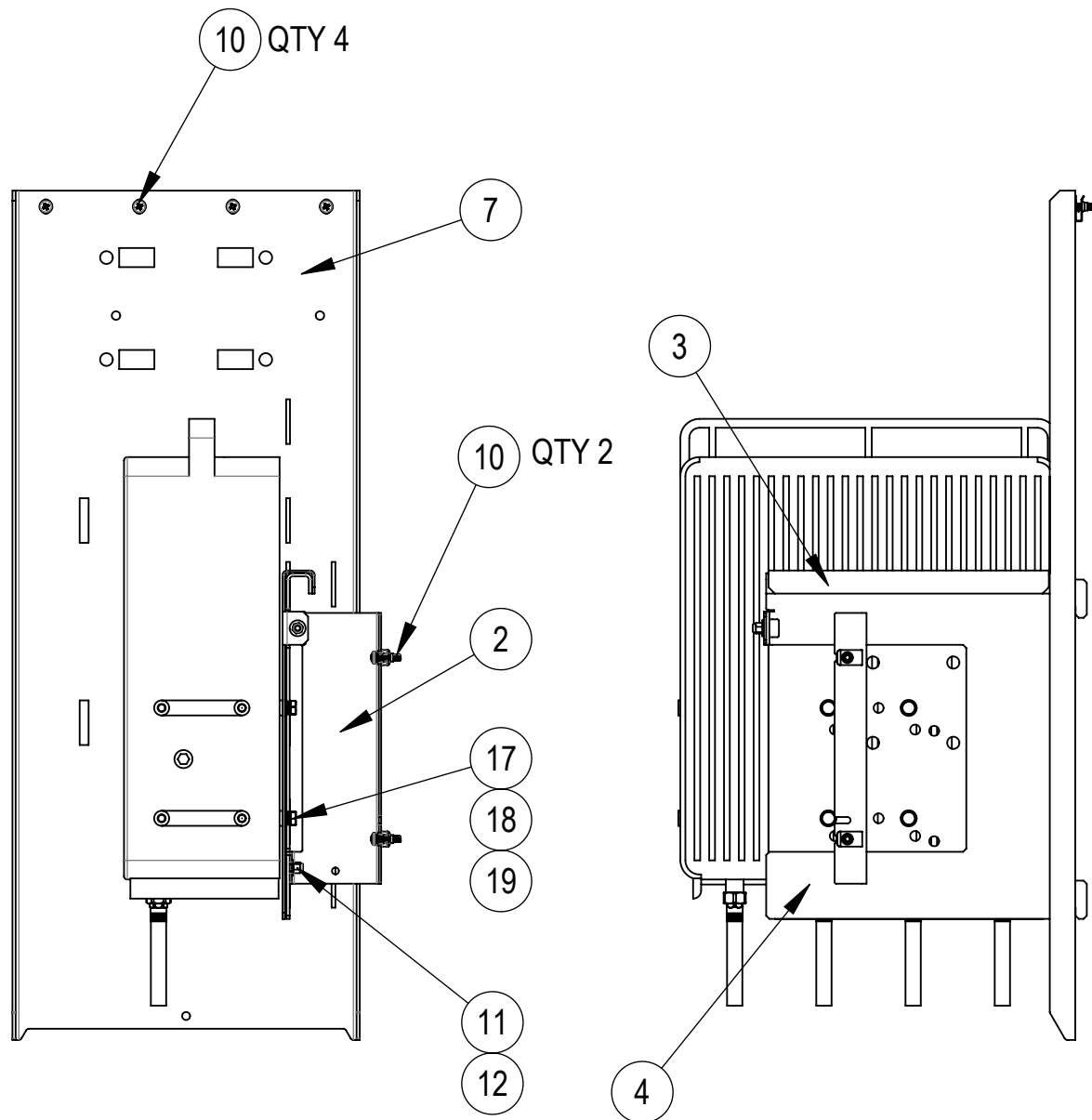
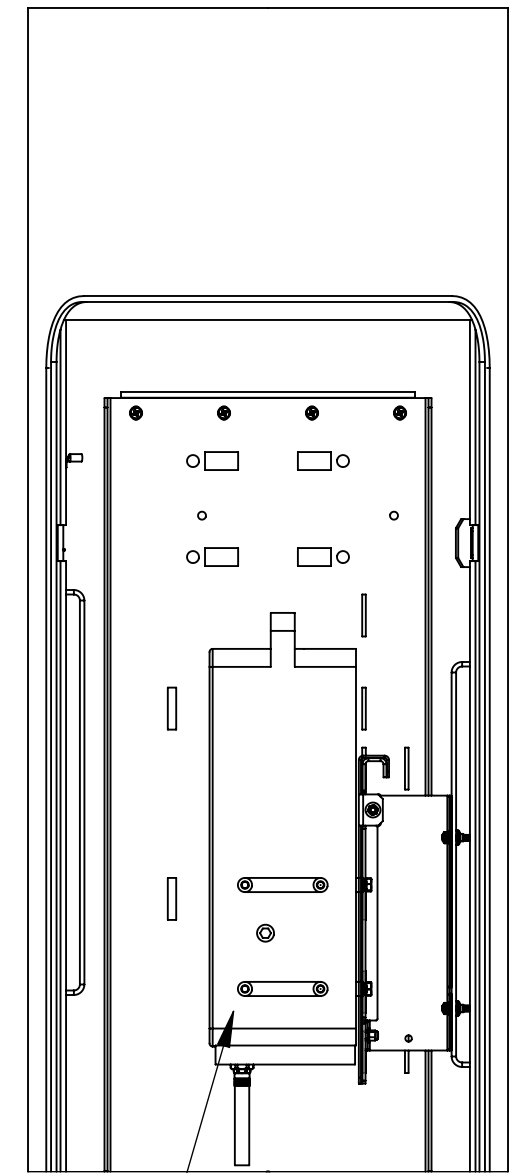

STEP 3 :
MTM1193-1112-BR
1. INSTALL ONE SIDE OF THE MOUNTING BRACKET MTM1193-1112-BR TO BRACKET OF ASSEMBLY USING 2 SETS OF M6 SEMS SCREWS, CLIP NUTS AND THE OTHER SIDE (AVOIDED SLOT) TO THE MOUNTING BRACKET MTM1160-1162-BR USING 2 SETS OF 1/4" NUTS AND FLAT WASHERS

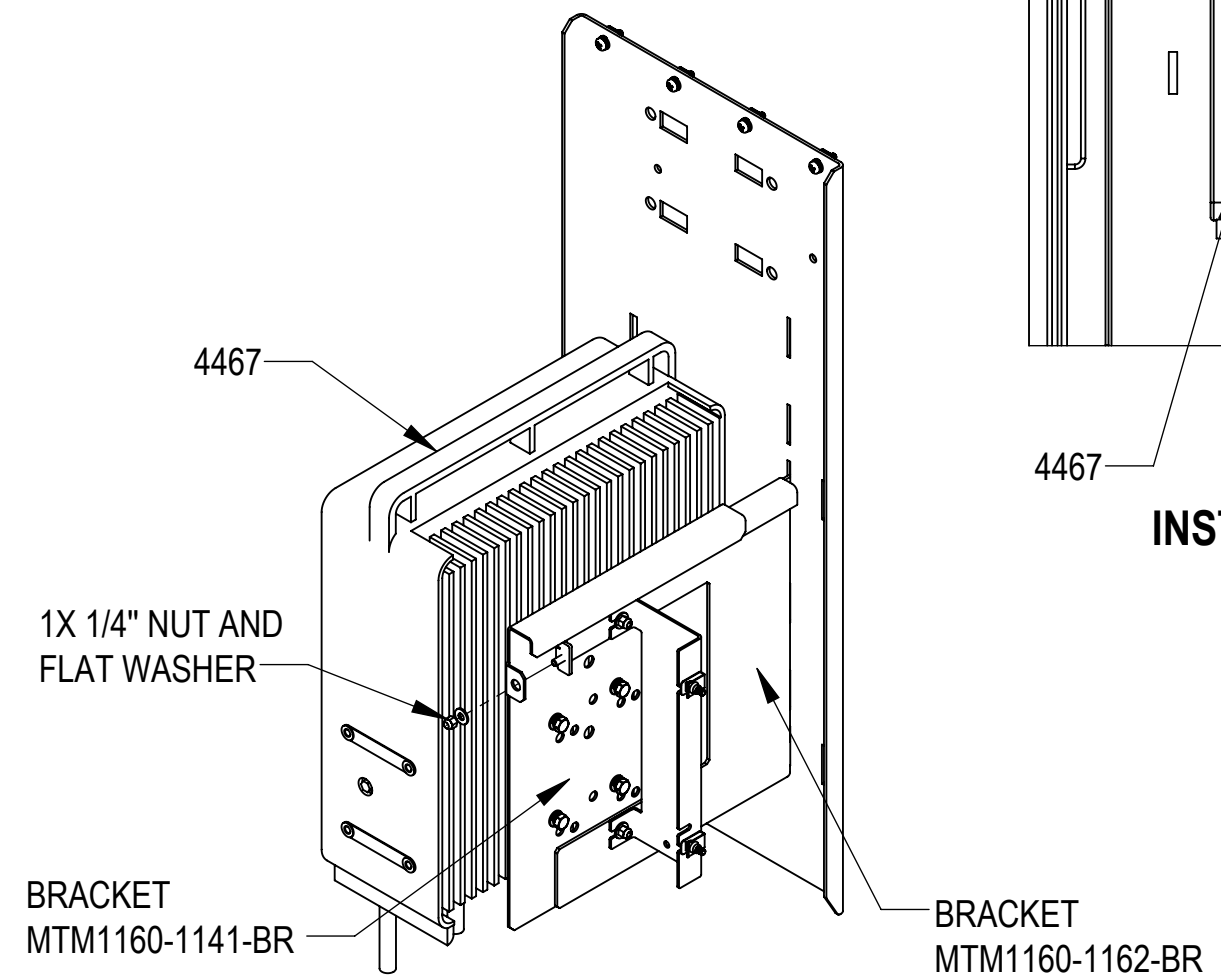

STEP 4 :
MTM1160-1141-BR (4490)
1. HANG THE MOUNTING BRACKET MTM1160-1141-BR TO THE MOUNTING BRACKET MTM1160-1162-BR AND LOCK THE SIDE USING 1 SET OF 1/4" NUT AND FLAT WASHER

BOM FOR 4467 INSTALLATION

ITEM NO.	PART NUMBER	DESCRIPTION	QTY.
2	MTM1193-1112-BR	BRKT LG SPRT 4 HOOK & HANG PB20GA-0.375	1
3	MTM1160-1141-BR	BRKT SLIDE HANGER ERICSON PB20GA	1
4	MTM1160-1162-BR	BRACKET, HANGING RAIL MOVEABLE PB20GA	1
7	MTM1160-1169-BR	BRKT MAIN HK & HANG REAR PLT PB20GA	1
9	460143456	CLIP NUT, M6, 316 SST	2
10	100117-4	FA,SEMS,PH,XRES,M6X25,SST,PASS	6
11	SNYL02	1/4" SS NYLOCK HEX NUT	3
12	SWF-02	FLAT WASHER, 1/4" SS	3
17	MTC9415	M8 X 25mm HEX BOLT SS	4
18	MTC9418	M8 LOCK WASHER SS	4
19	MTC9419	M8 FLAT WASHER SS	4

E11 (IP20): 4467 INSTALLATION

EQUIPMENT INSTALLATION SEE SHEET 4
TORQUE ALL TO SPEC



TITLE KIT ERICSSON INSTALL INTO PB20GA-0.375			
SIZE C	SCALE 1:10	DOCUMENT NO. MTM1193-1101-AMK-E	
DRAWING			SHEET
VERSION 04	STATUS RE	REVISION E	17 OF 21

Confidential

4

3

2

1

D

D

C

C

B

B

A

A

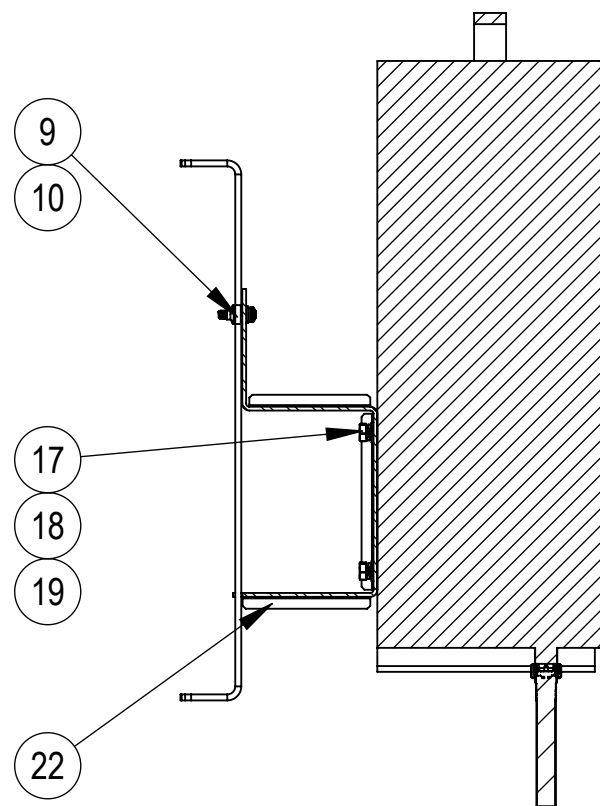
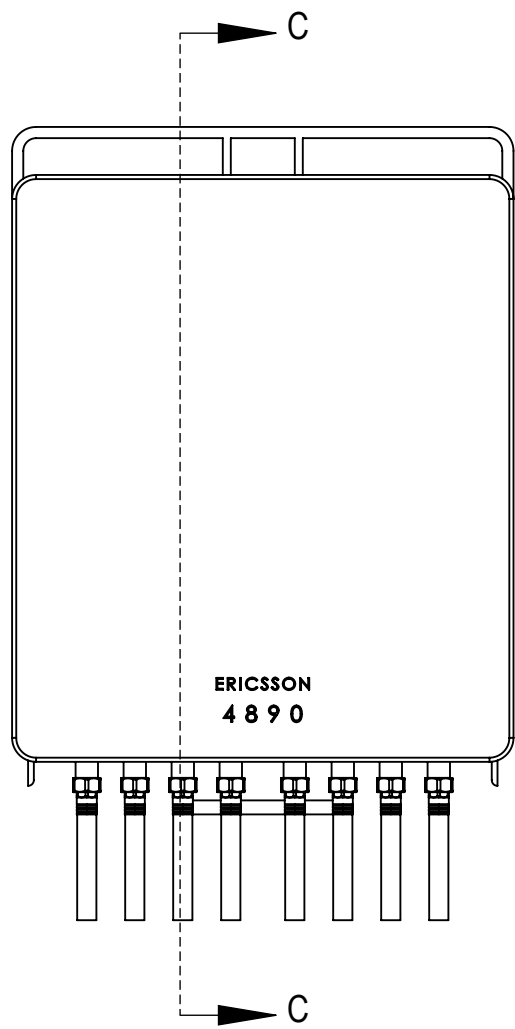
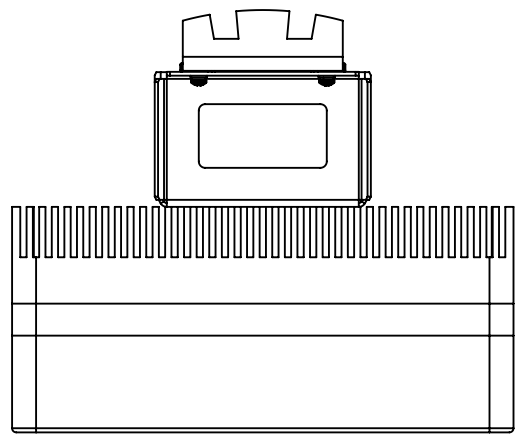

SECTION C-C
SCALE 1 : 6

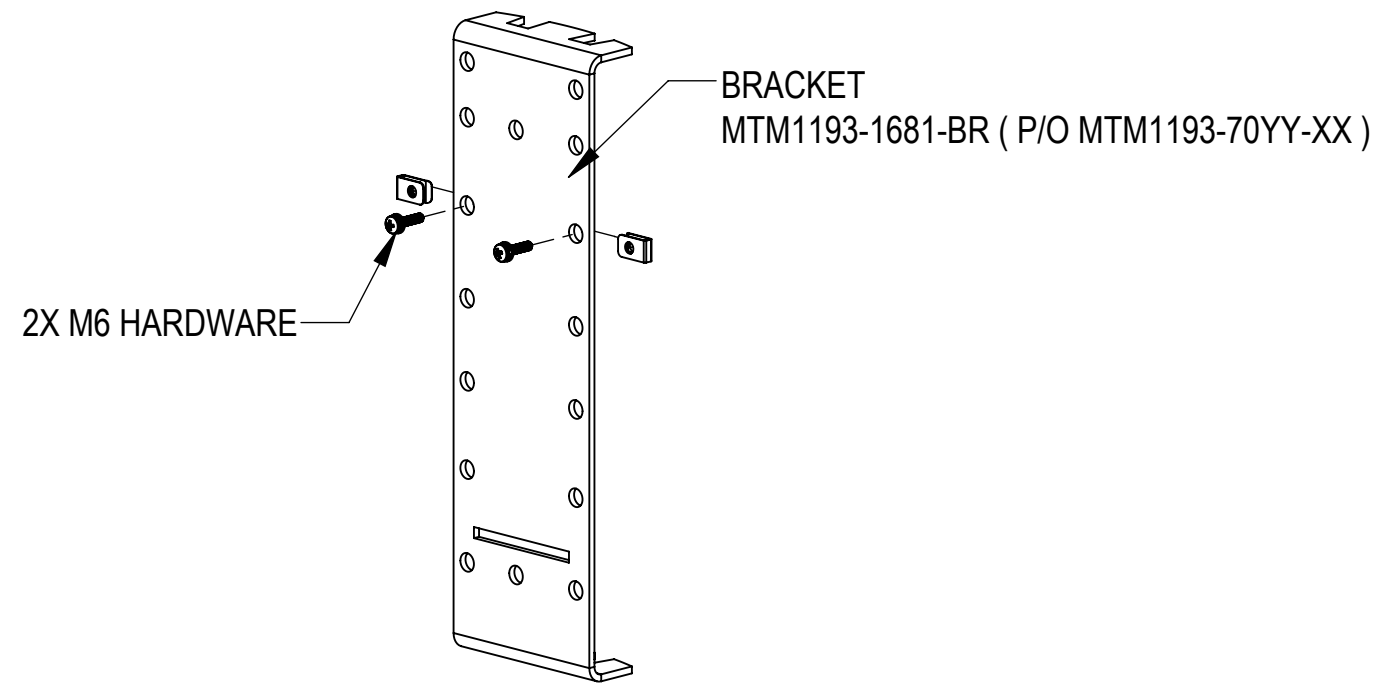

STEP 1 :

MTM1193-1681-BR (IN IP20)

1. PRE-INSTALL 2 SETS OF M6 SEMS SCREWS AND CLIP NUTS TO THE BRACKET MTM1193-1681-BR OF THE IP20

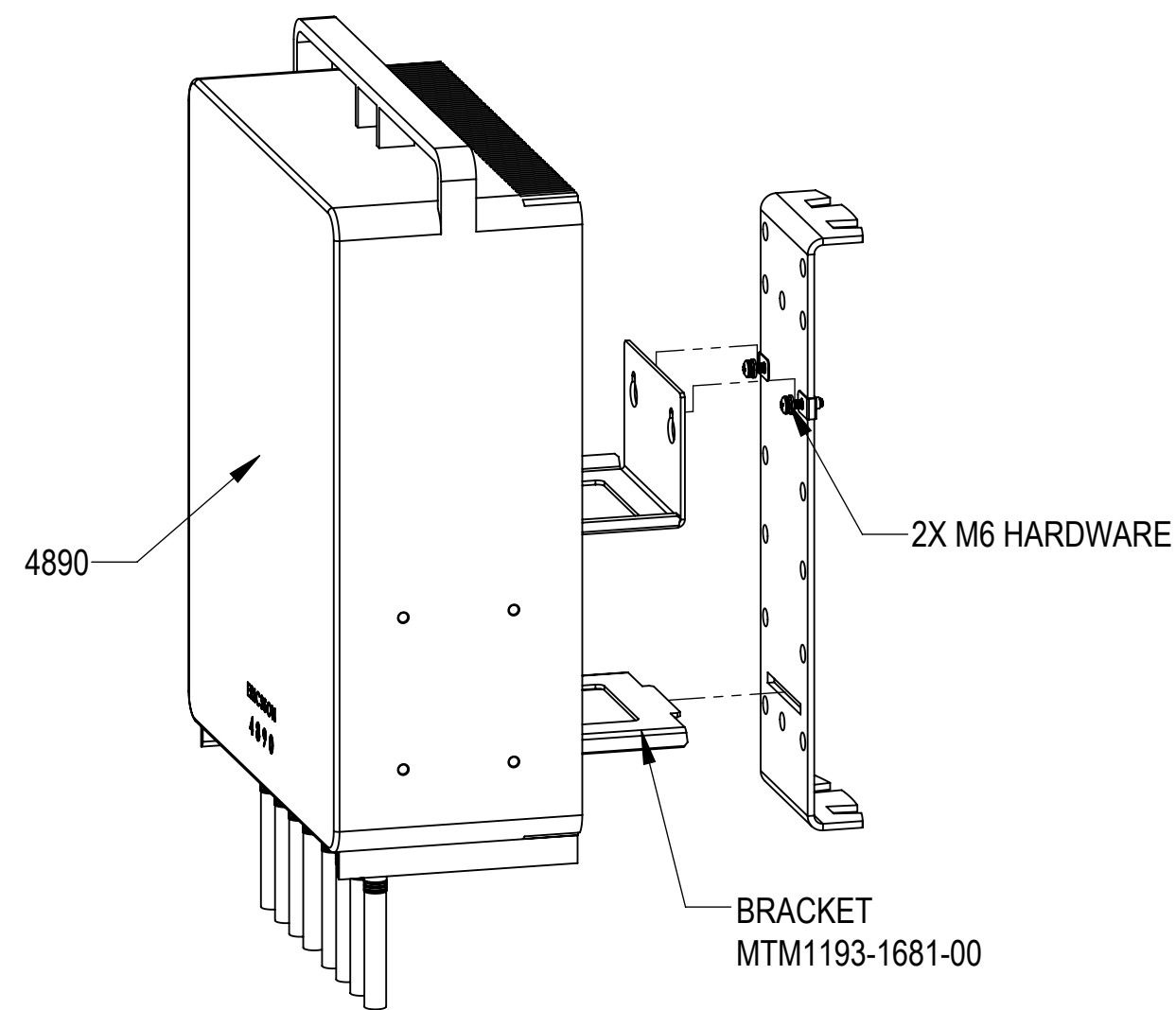

STEP 2 :

MTM1193-1681-00(4890)

1. HANG THE 4890-ASSEMBLY TO THE BRACKET MTM1193-1681-BR OF THE IP20
2. FIX THE 4890-ASSEMBLY TO THE BRACKET OF THE IP20 USING 2 SETS OF M6 BOLTS AND CLIP NUTS

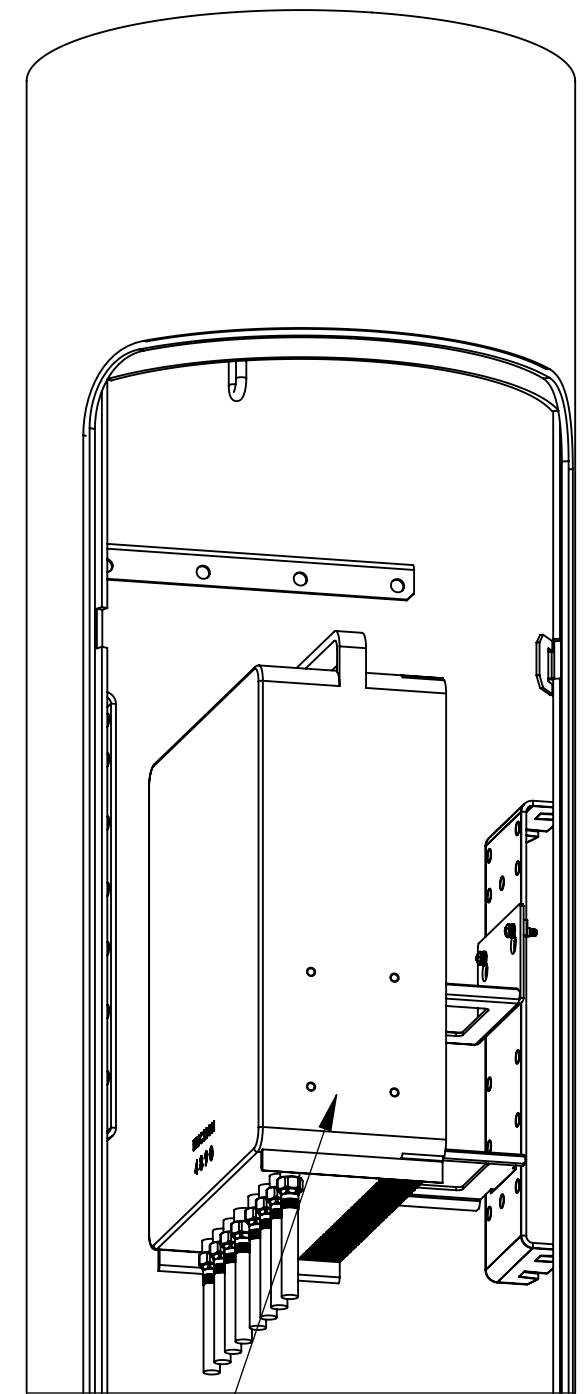

INSTALLED VIEW

BOM FOR 4490 INSTALLATION

ITEM NO.	PART NUMBER	DESCRIPTION	QTY.
9	460143456	CLIP NUT, M6, 316 SST	2
10	100117-4	FA,SEMS,PH,XRES,M6X25,SST,PASS	2
17	MTC9415	M8 X 25mm HEX BOLT SS	4
18	MTC9418	M8 LOCK WASHER SS	4
19	MTC9419	M8 FLAT WASHER SS	4
22	MTM1193-1681-00	BRKT MOUNT RU4890 AND 4490	1

E12 (IP20) : 4890 INSTALLATION

EQUIPMENT INSTALLATION SEE SHEET 4
TORQUE ALL TO SPEC



TITLE KIT ERICSSON INSTALL INTO PB20GA-0.375			
SIZE C	SCALE 1:10	DOCUMENT NO. MTM1193-1101-AMK-E	
DRAWING			SHEET
VERSION 04	STATUS RE	REVISION E	18 OF 21

Confidential

4

3

2

1

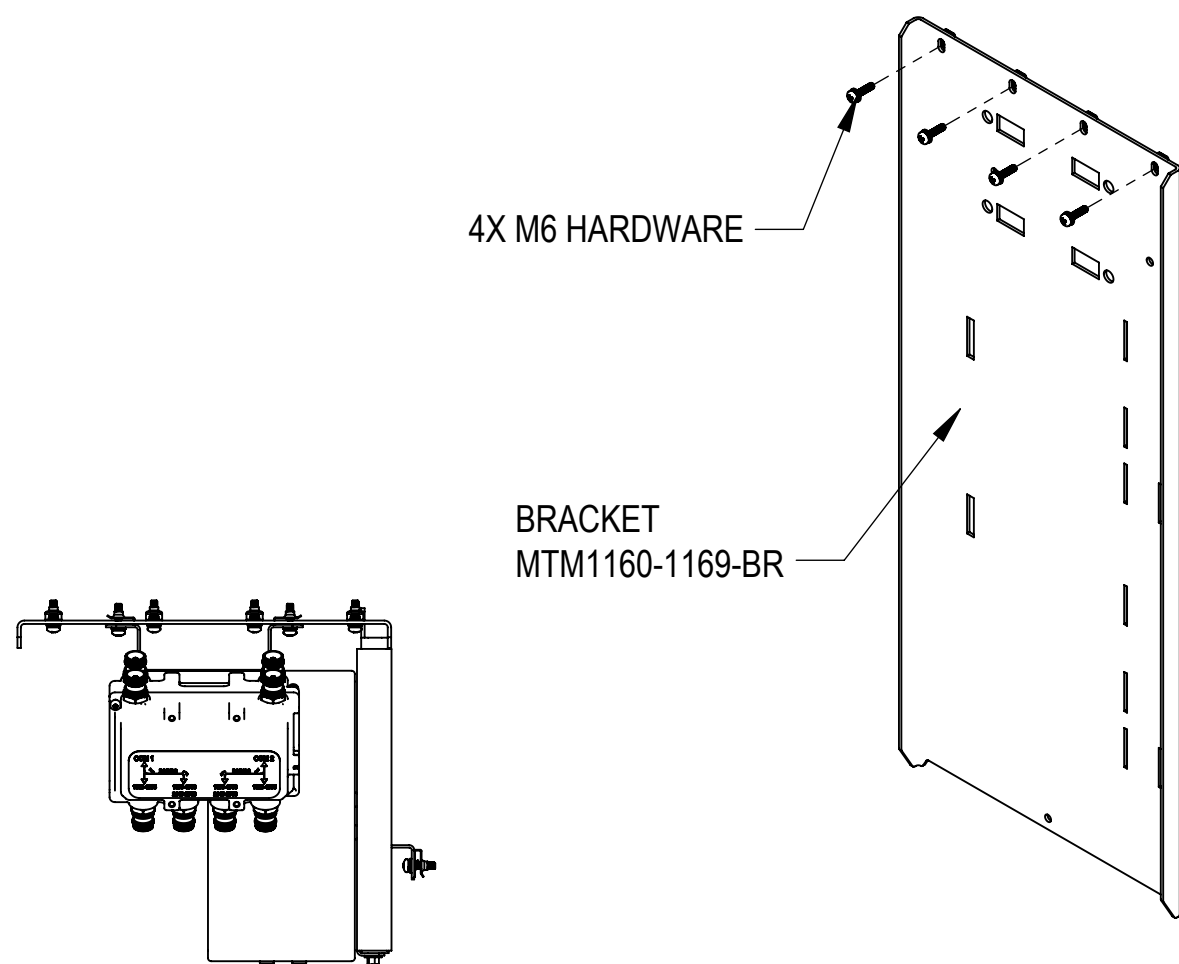

STEP 1 :
MTM1160-1169-BR

1. INSTALL THE MOUNTING BRACKET MTM1160-1169-BR TO BRACKET OF ASSEMBLY USING 4 SETS OF M6 SEMS SCREWS AND CLIP NUTS

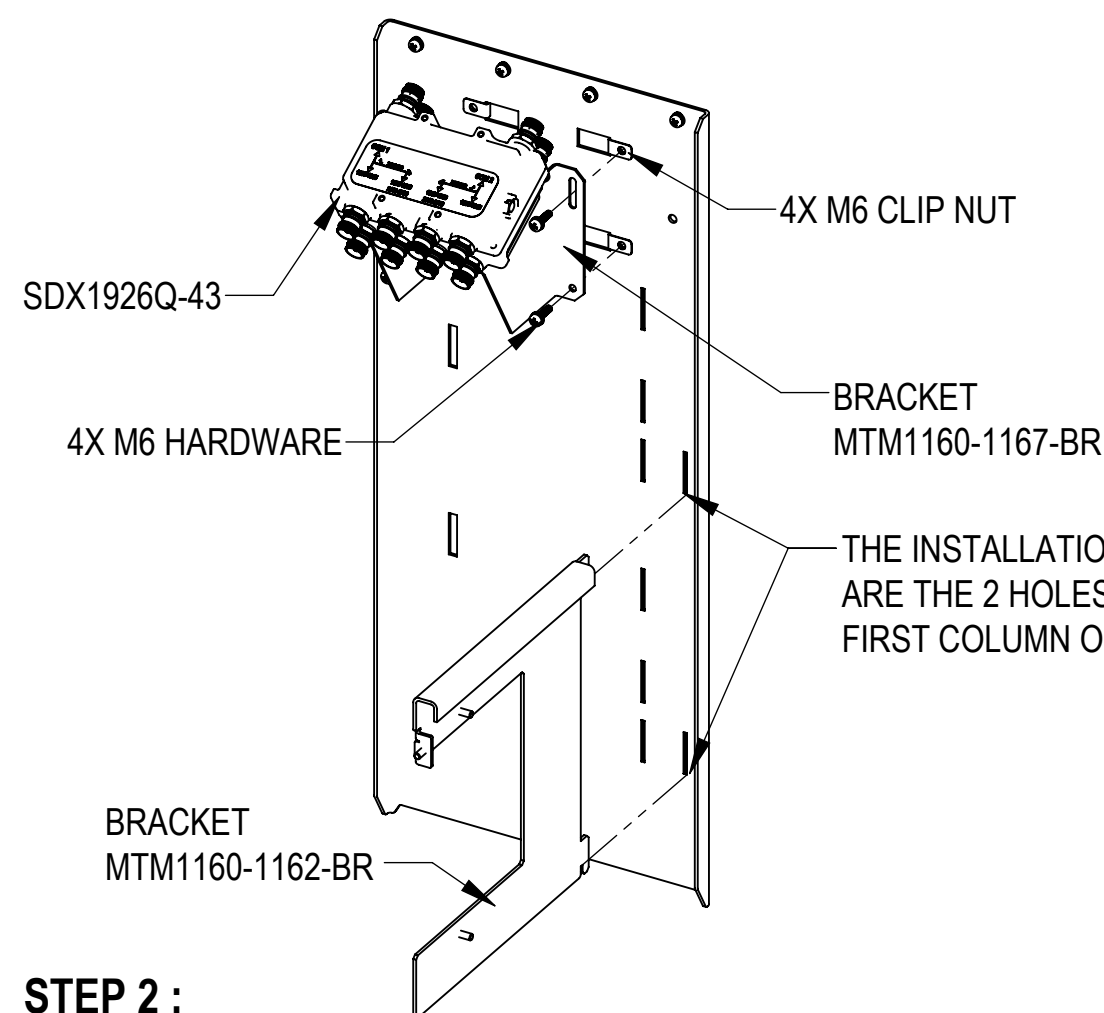

STEP 2 :
MTM1160-1167-BR (SDX1926Q-43) + MTM1160-1162-BR

1. INSTALL M6 CLIP NUTS AS SHOWN
2. INSTALL THE MOUNTING BRACKET MTM1160-1167-BR TO THE MOUNTING BRACKET MTM1160-1169-BR USING 4 SETS OF SEMS SCREWS.
3. HANG THE MOUNTING BRACKET MTM1160-1162-BR TO THE 2 HOLES FROM THE FIRST COLUMN OUTSIDE OF THE MOUNTING BRACKET MTM1160-1169-BR

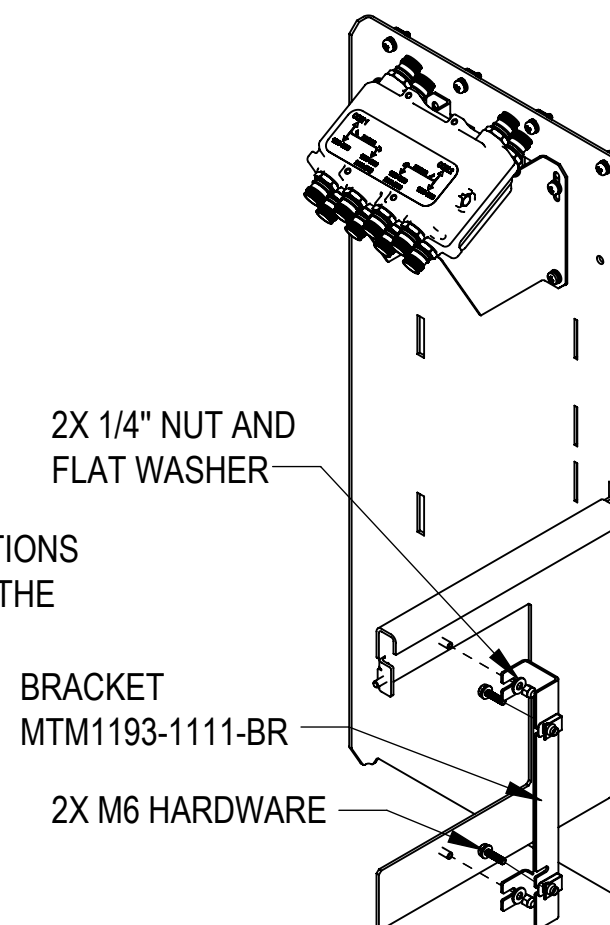

STEP 3 :
MTM1193-1111-BR

1. INSTALL ONE SIDE OF THE MOUNTING BRACKET MTM1193-1111-BR TO BRACKET OF ASSEMBLY USING 2 SETS OF M6 SEMS SCREWS, CLIP NUTS AND THE OTHER SIDE(AVOIDED SLOT) TO THE MOUNTING BRACKET MTM1160-1162-BR USING 2 SETS OF 1/4" NUTS, FLAT WASHERS

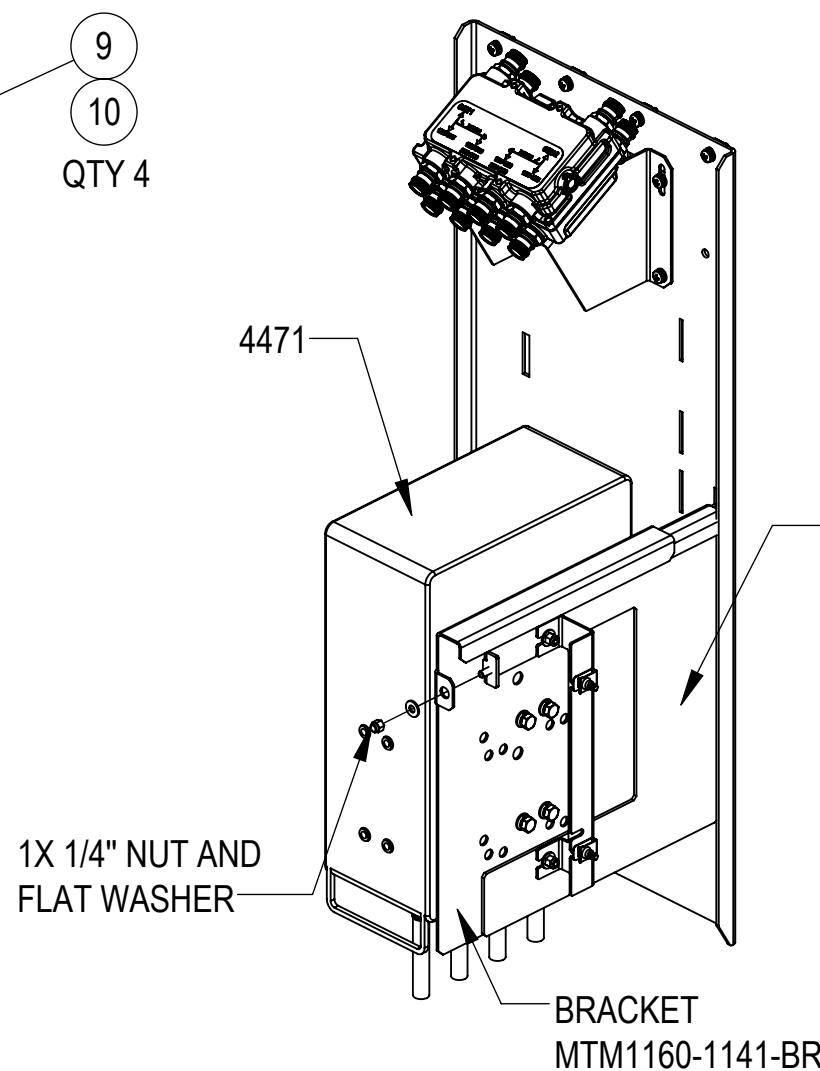
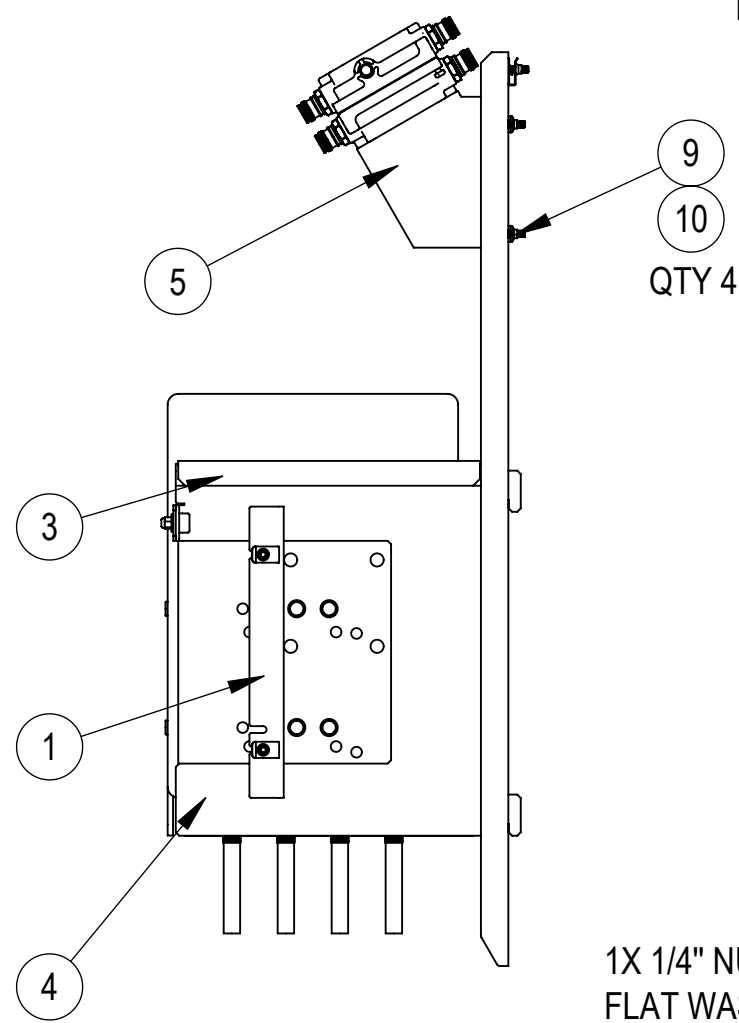
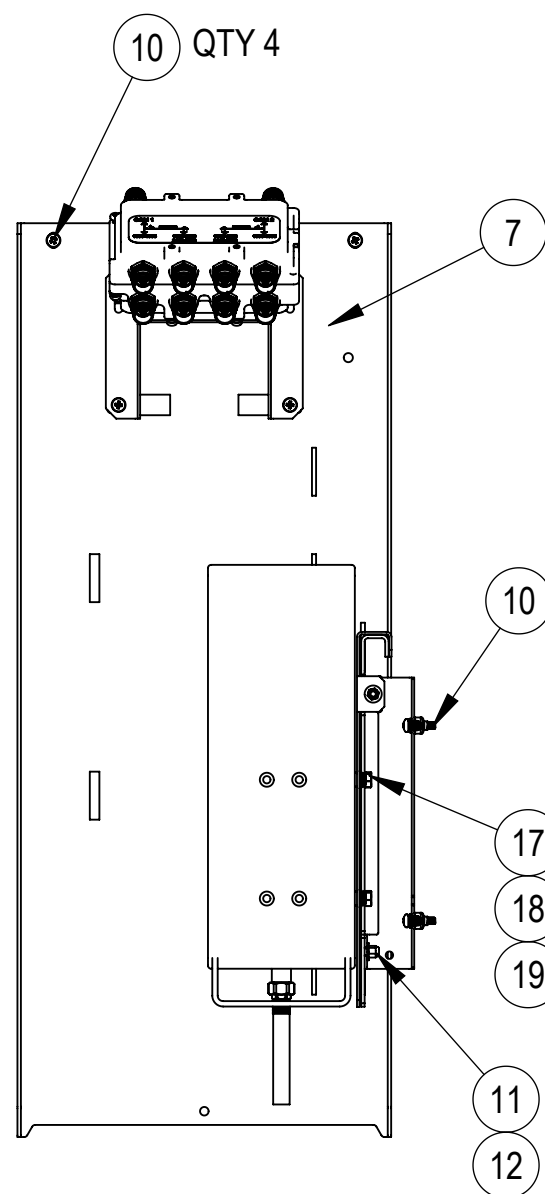
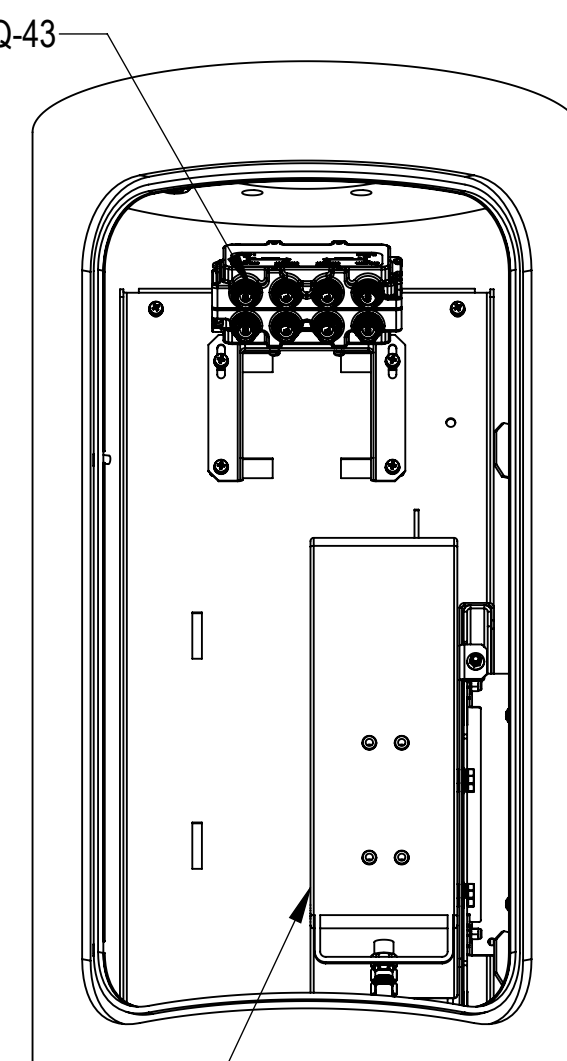

STEP 4 :
MTM1160-1141-BR (4471)

1. HANG THE MOUNTING BRACKET MTM1160-1141-BR TO THE MOUNTING BRACKET MTM1160-1162-BR AND LOCK THE SIDE USING 1 SET OF 1/4" NUT AND FLAT WASHER

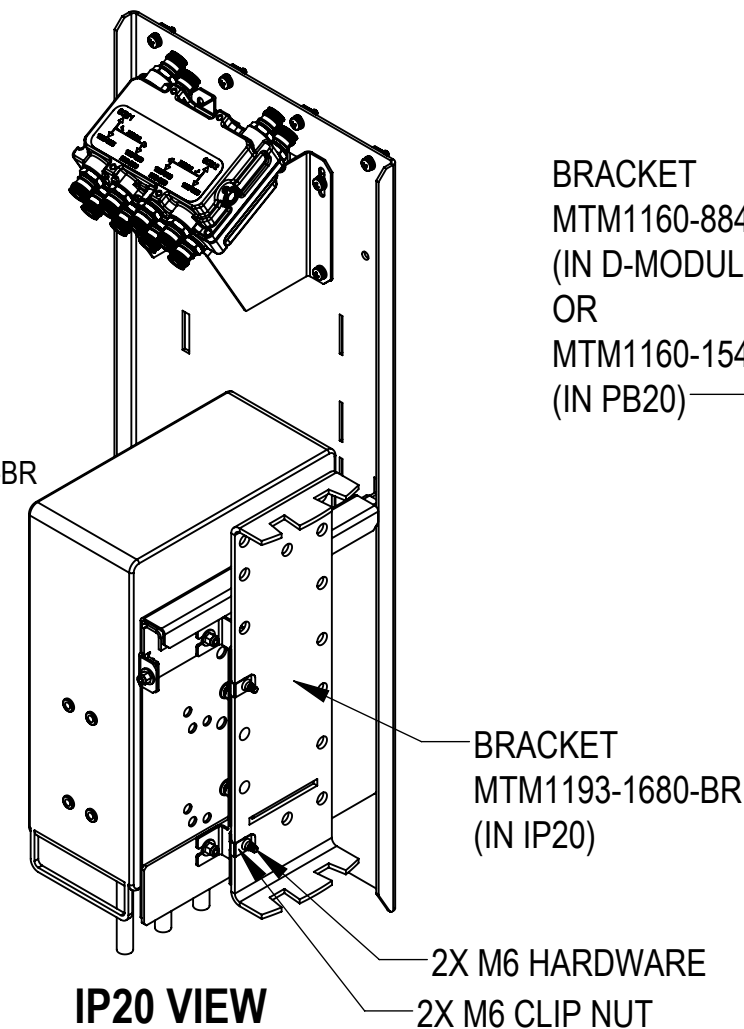

STEP 5 :

1. INSTALLED ABOVE SUB-ASSY TO POLE FRAME (PB20, D-MODULE & IP20)

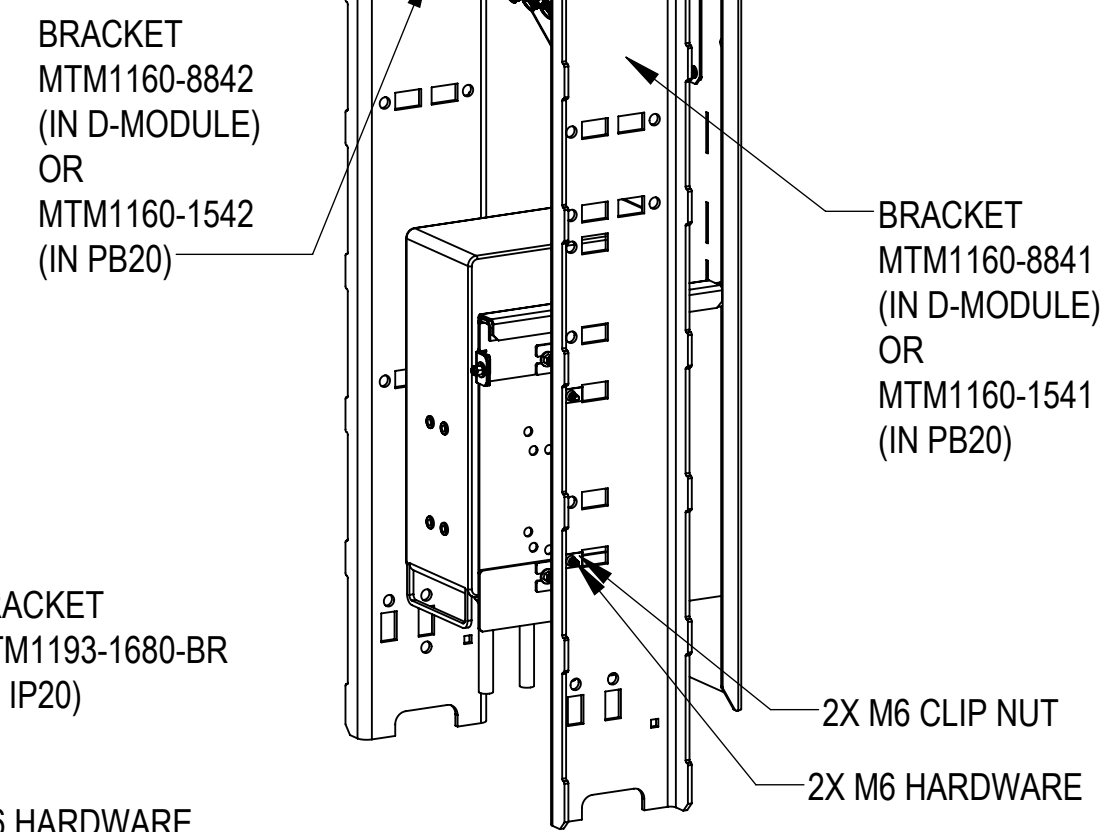

PB20 OR D-MODULE VIEW

BOM FOR 4471 + QUAD DIPLEXER SDX1926Q-43 INSTALLATION

ITEM NO.	PART NUMBER	DESCRIPTION	QTY.
1	MTM1193-1111-BR	BRKT SM SPRT 4 HOOK & HANG PB20GA-0.375	1
3	MTM1160-1141-BR	BRKT SLIDE HANGER ERICSON PB20GA	1
4	MTM1160-1162-BR	BRACKET, HANGING RAIL MOVEABLE PB20GA	1
5	MTM1160-1167-BR	BRKT DIPLEX MNTG TOP/ANGLE PB20GA	1
7	MTM1160-1169-BR	BRKT MAIN HK & HANG REAR PLT PB20GA	1
9	460143456	CLIP NUT, M6, 316 SST	4
10	100117-4	FA,SEMS,PH,XRES,M6X25,SST,PASS	10
11	SNYL02	1/4" SS NYLOCK HEX NUT	3
12	SWF-02	FLAT WASHER, 1/4" SS	3
17	MTC9415	M8 X 25mm HEX BOLT SS	4
18	MTC9418	M8 LOCK WASHER SS	4
19	MTC9419	M8 FLAT WASHER SS	4

E13: 4471 + QUAD DIPLEXER SDX1926Q-43 INSTALLATION

EQUIPMENT INSTALLATION SEE SHEET 4 & 5
TORQUE ALL TO SPEC

Confidential

ANDREW an Amphenol company

TITLE
KIT ERICSSON INSTALL INTO PB20GA-0.375

SIZE **C** SCALE **1:10** DOCUMENT NO. MTM1193-1101-AMK-E

DRAWING			SHEET 19 OF 21
VERSION 04	STATUS RE	REVISION E	

D

C

B

A

D

C

B

A

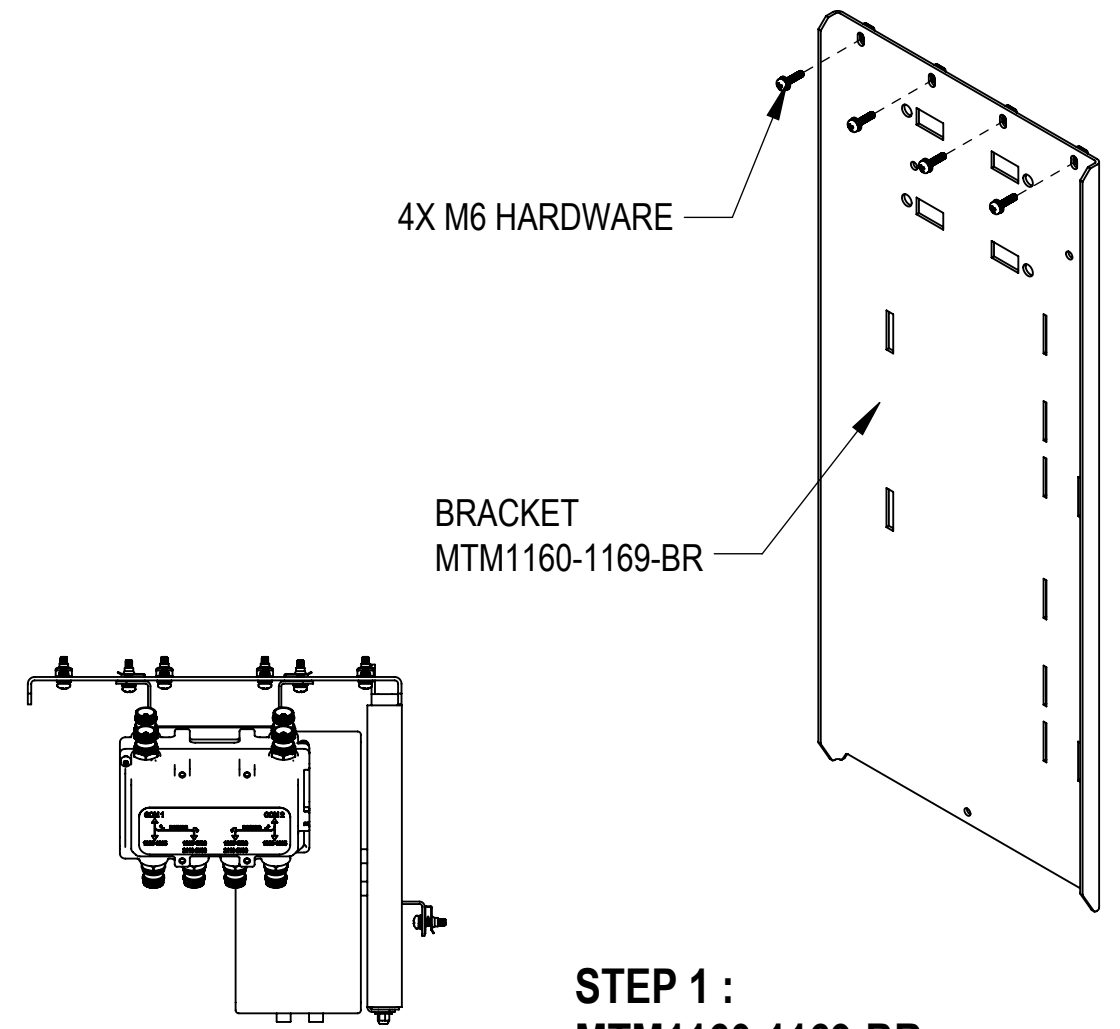

STEP 1 :
MTM1160-1169-BR

1. INSTALL THE MOUNTING BRACKET MTM1160-1169-BR TO BRACKET OF ASSEMBLY USING 4 SETS OF M6 SEMS SCREWS AND CLIP NUTS

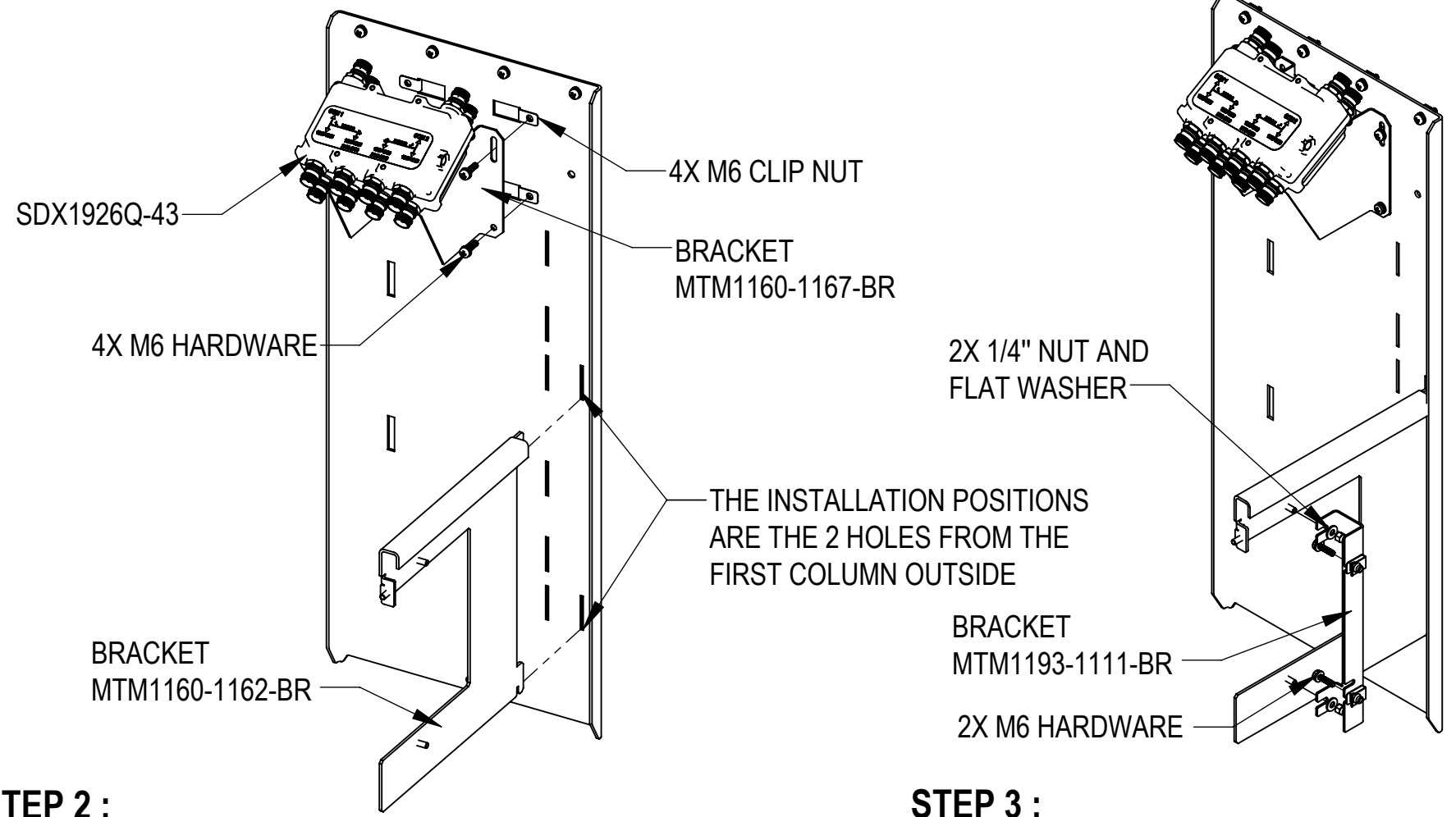

STEP 2 :
MTM1160-1167-BR (SDX1926Q-43) + MTM1160-1162-BR

1. INSTALL M6 CLIP NUTS AS SHOWN
2. INSTALL THE MOUNTING BRACKET MTM1160-1167-BR TO THE MOUNTING BRACKET MTM1160-1169-BR USING 4 SETS OF SEMS SCREWS.
3. HANG THE MOUNTING BRACKET MTM1160-1162-BR TO THE 2 HOLES FROM THE FIRST COLUMN OUTSIDE OF THE MOUNTING BRACKET MTM1160-1169-BR

STEP 3 :
MTM1193-1111-BR

1. INSTALL ONE SIDE OF THE MOUNTING BRACKET MTM1193-1111-BR TO BRACKET OF ASSEMBLY USING 2 SETS OF M6 SEMS SCREWS, CLIP NUTS AND THE OTHER SIDE (AVOIDED SLOT) TO THE MOUNTING BRACKET MTM1160-1162-BR USING 2 SETS OF 1/4" NUTS, FLAT WASHERS

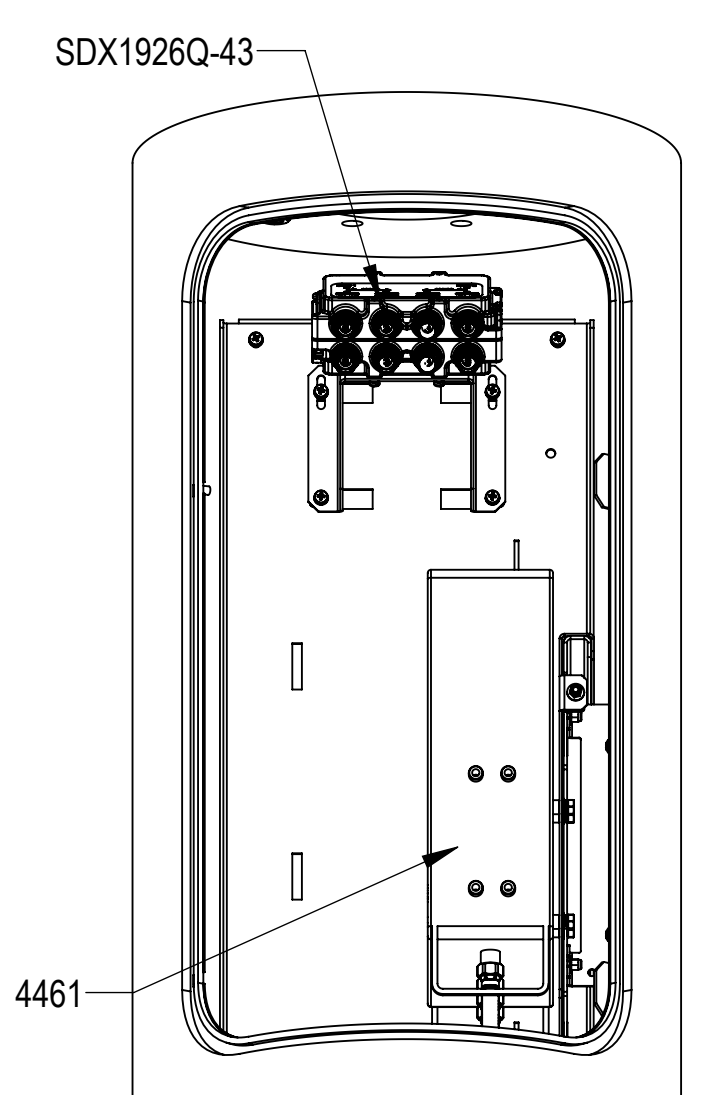

INSTALLED VIEW

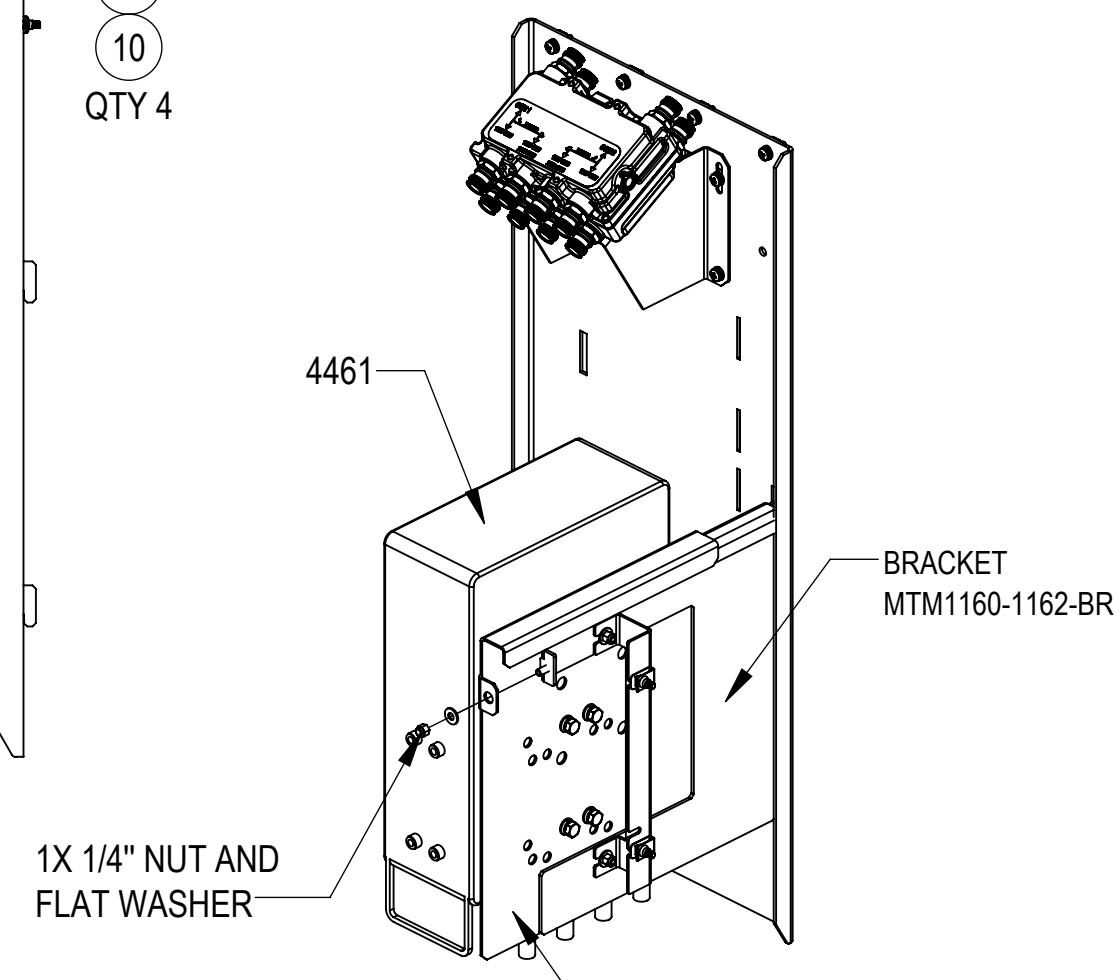
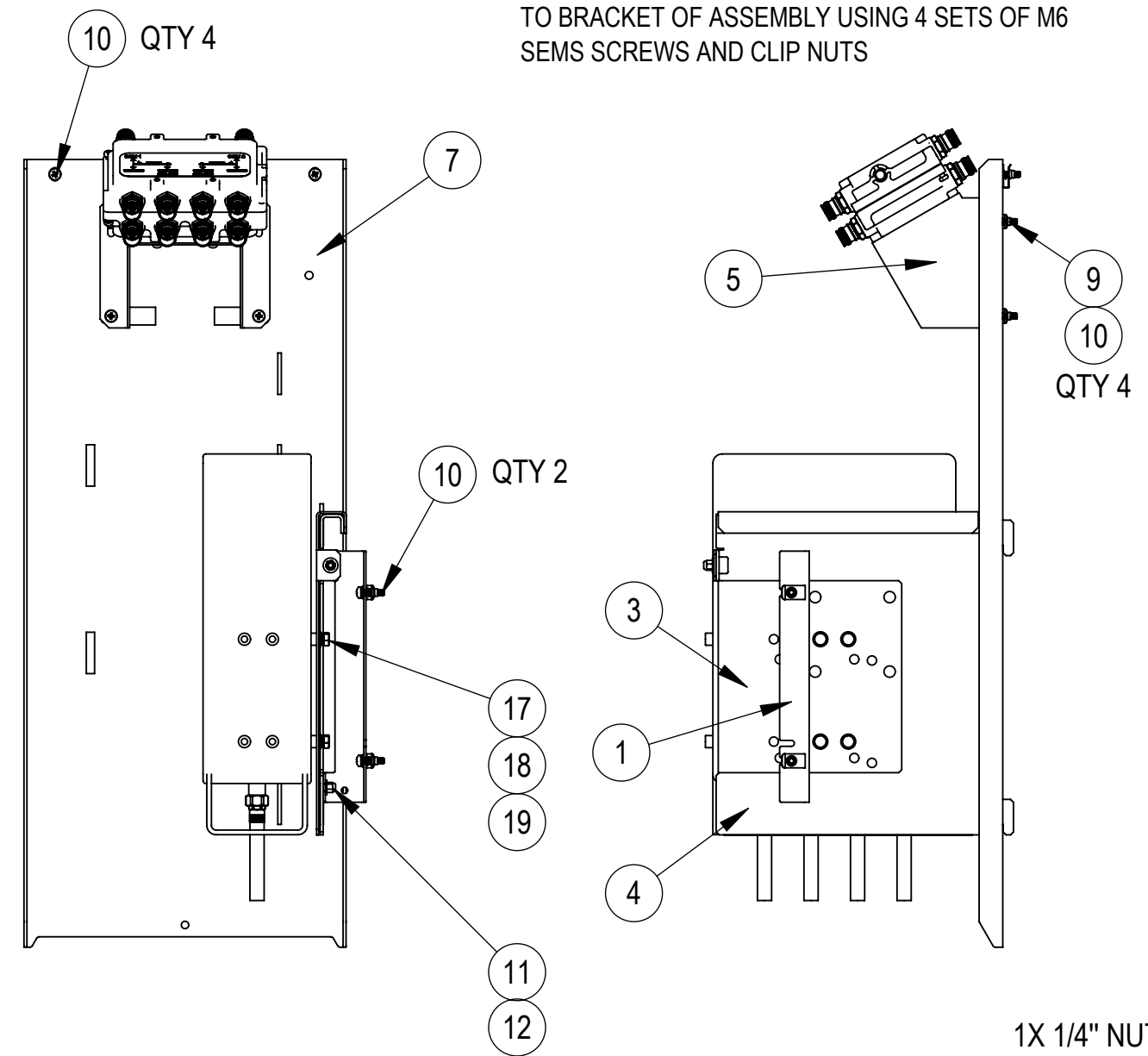

STEP 4 :
MTM1160-1141-BR (4471)

1. HANG THE MOUNTING BRACKET MTM1160-1141-BR TO THE MOUNTING BRACKET MTM1160-1162-BR AND LOCK THE SIDE USING 1 SET OF 1/4" NUT AND FLAT WASHER

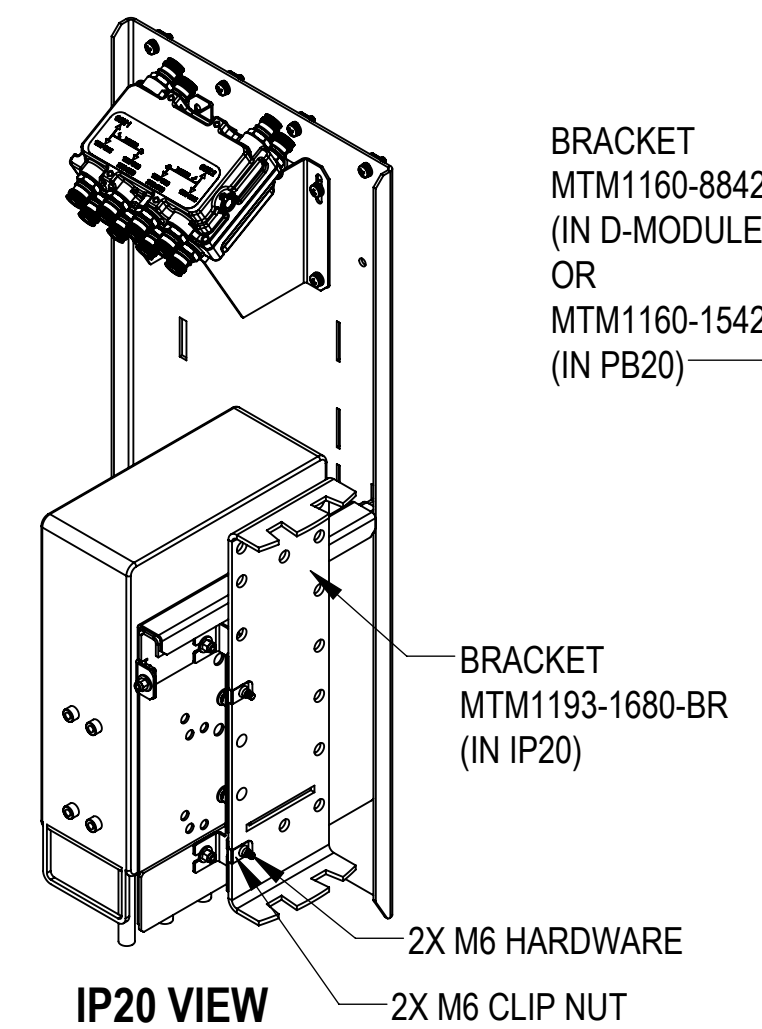

IP20 VIEW

- STEP 5 :**
1. INSTALLED ABOVE SUB-ASSY TO POLE FRAME (PB20, D-MODULE & IP20)

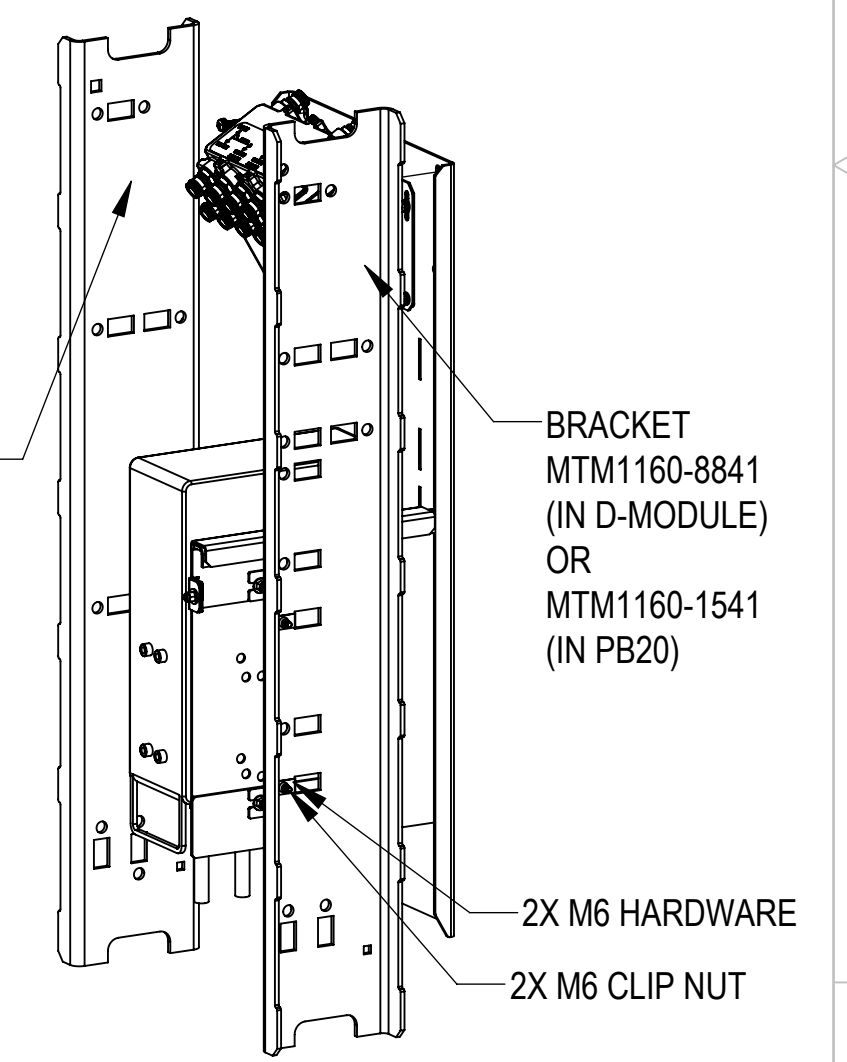

PB20 OR D-MODULE VIEW

BOM FOR 4461 + QUAD DIPLEXER SDX1926Q-43 INSTALLATION

ITEM NO.	PART NUMBER	DESCRIPTION	QTY.
1	MTM1193-1111-BR	BRKT SM SPRT 4 HOOK & HANG PB20GA-0.375	1
3	MTM1160-1141-BR	BRKT SLIDE HANGER ERCISON PB20GA	1
4	MTM1160-1162-BR	BRACKET, HANGING RAIL MOVEABLE PB20GA	1
5	MTM1160-1167-BR	BRKT DIPLEX MNTG TOP/ANGLE PB20GA	1
7	MTM1160-1169-BR	BRKT MAIN HK & HANG REAR PLT PB20GA	1
9	460143456	CLIP NUT, M6, 316 SST	4
10	100117-4	FA,SEMS,PH,XRES,M6X25,SST,PASS	10
11	SNYL02	1/4" SS NYLOCK HEX NUT	3
12	SWF-02	FLAT WASHER, 1/4" SS	3
17	MTC9415	M8 X 25mm HEX BOLT SS	4
18	MTC9418	M8 LOCK WASHER SS	4
19	MTC9419	M8 FLAT WASHER SS	4

E14: 4461 + QUAD DIPLEXER SDX1926Q-43 INSTALLATION

EQUIPMENT INSTALLATION SEE SHEET 4 & 5
TORQUE ALL TO SPEC

Confidential

ANDREW an Amphenol company

TITLE
KIT ERICSSON INSTALL INTO PB20GA-0.375

SIZE **C** SCALE **1:10** DOCUMENT NO. MTM1193-1101-AMK-E

DRAWING			SHEET 20 OF 21
VERSION 04	STATUS RE	REVISION E	

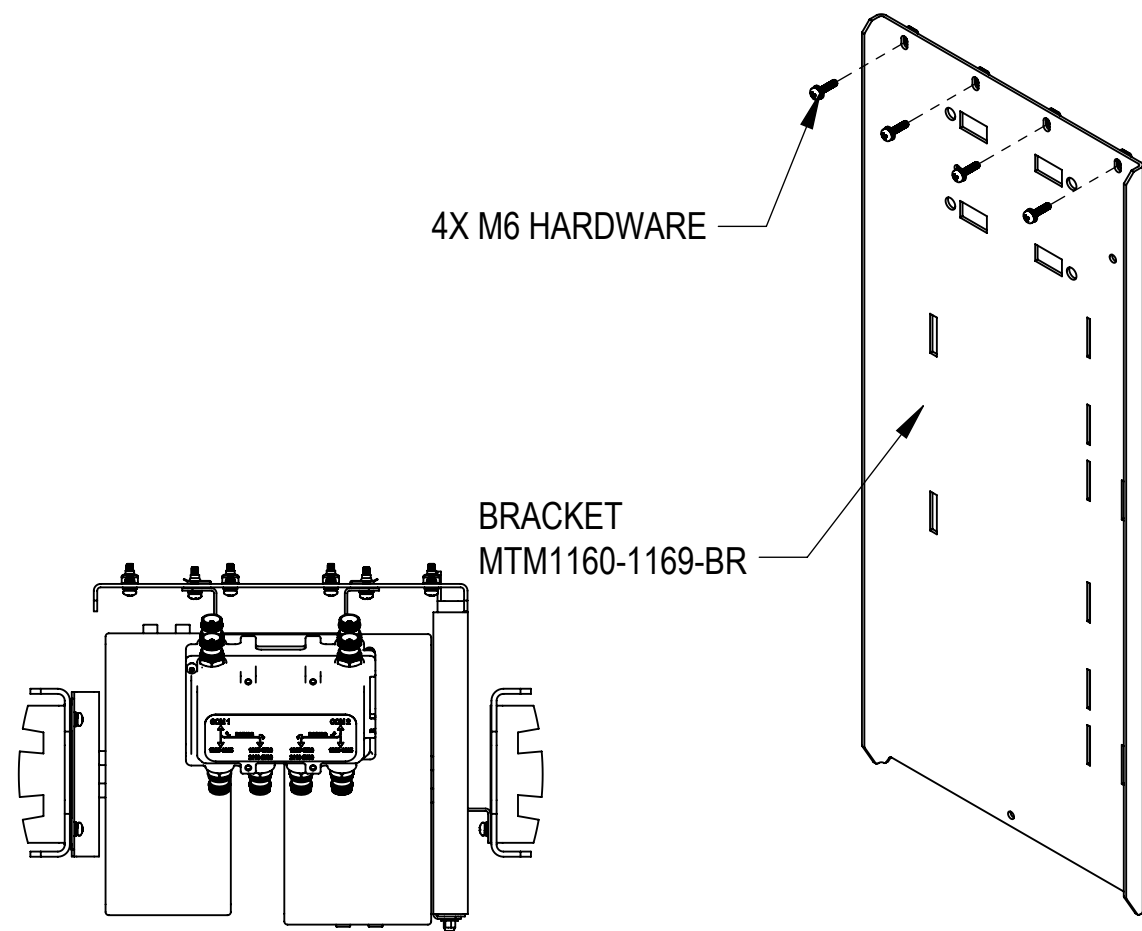

4X M6 HARDWARE

BRACKET MTM1160-1169-BR

STEP 1 :
MTM1160-1169-BR

1. INSTALL THE MOUNTING BRACKET MTM1160-1169-BR TO BRACKET OF ASSEMBLY USING 4 SETS OF M6 SEMS SCREWS AND CLIP NUTS

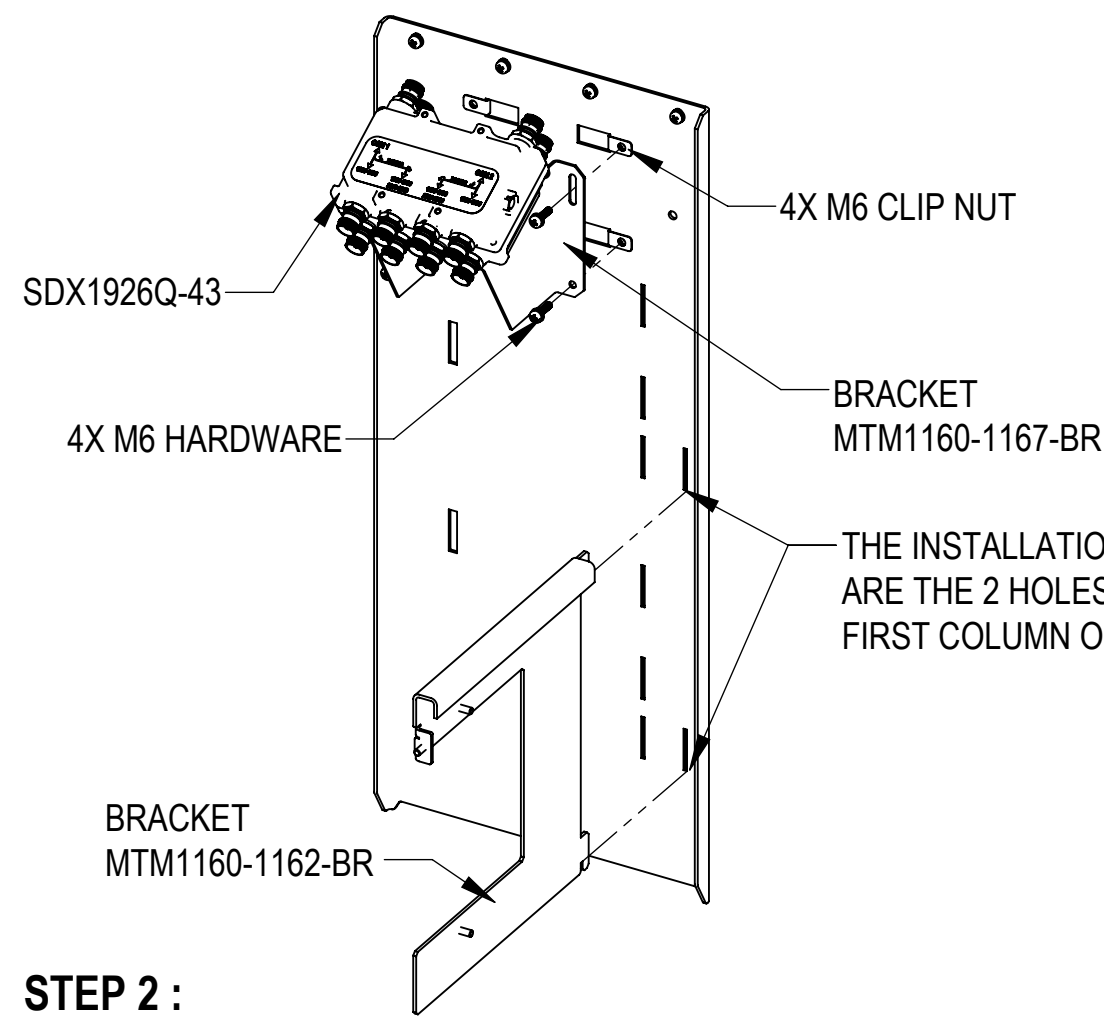

SDX1926Q-43

4X M6 CLIP NUT

4X M6 HARDWARE

BRACKET MTM1160-1167-BR

THE INSTALLATION POSITIONS ARE THE 2 HOLES FROM THE FIRST COLUMN OUTSIDE

BRACKET MTM1160-1162-BR

STEP 2 :
MTM1160-1167-BR (SDX1926Q-43) + MTM1160-1162-BR

1. INSTALL M6 CLIP NUTS AS SHOWN
2. INSTALL THE MOUNTING BRACKET MTM1160-1167-BR TO THE MOUNTING BRACKET MTM1160-1169-BR USING 4 SETS OF SEMS SCREWS.
3. HANG THE MOUNTING BRACKET MTM1160-1162-BR TO THE 2 HOLES FROM THE FIRST COLUMN OUTSIDE OF THE MOUNTING BRACKET MTM1160-1169-BR

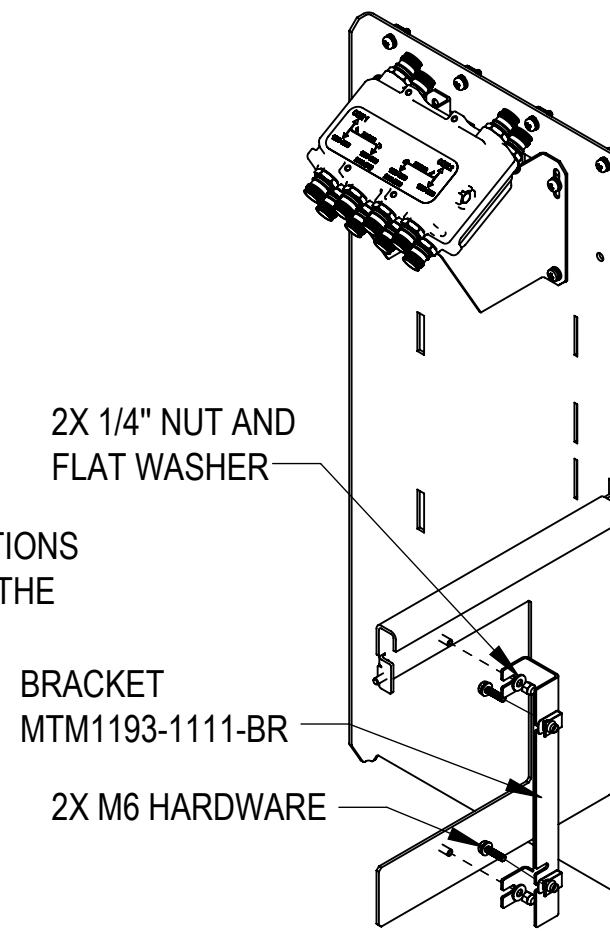

2X 1/4" NUT AND FLAT WASHER

BRACKET MTM1193-1111-BR

2X M6 HARDWARE

STEP 3 :
MTM1193-1111-BR

1. INSTALL ONE SIDE OF THE MOUNTING BRACKET MTM1193-1111-BR TO BRACKET OF ASSEMBLY USING 2 SETS OF M6 SEMS SCREWS, CLIP NUTS AND THE OTHER SIDE(AVOIDED SLOT) TO THE MOUNTING BRACKET MTM1160-1162-BR USING 2 SETS OF 1/4" NUTS, FLAT WASHERS

SDX1926Q-43

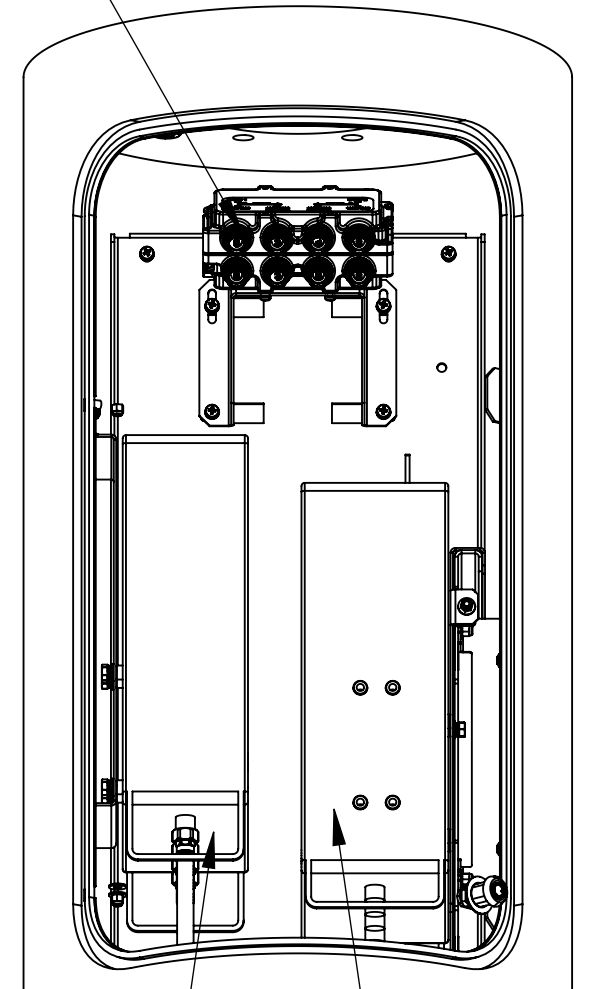

4461 4471

INSTALLED VIEW

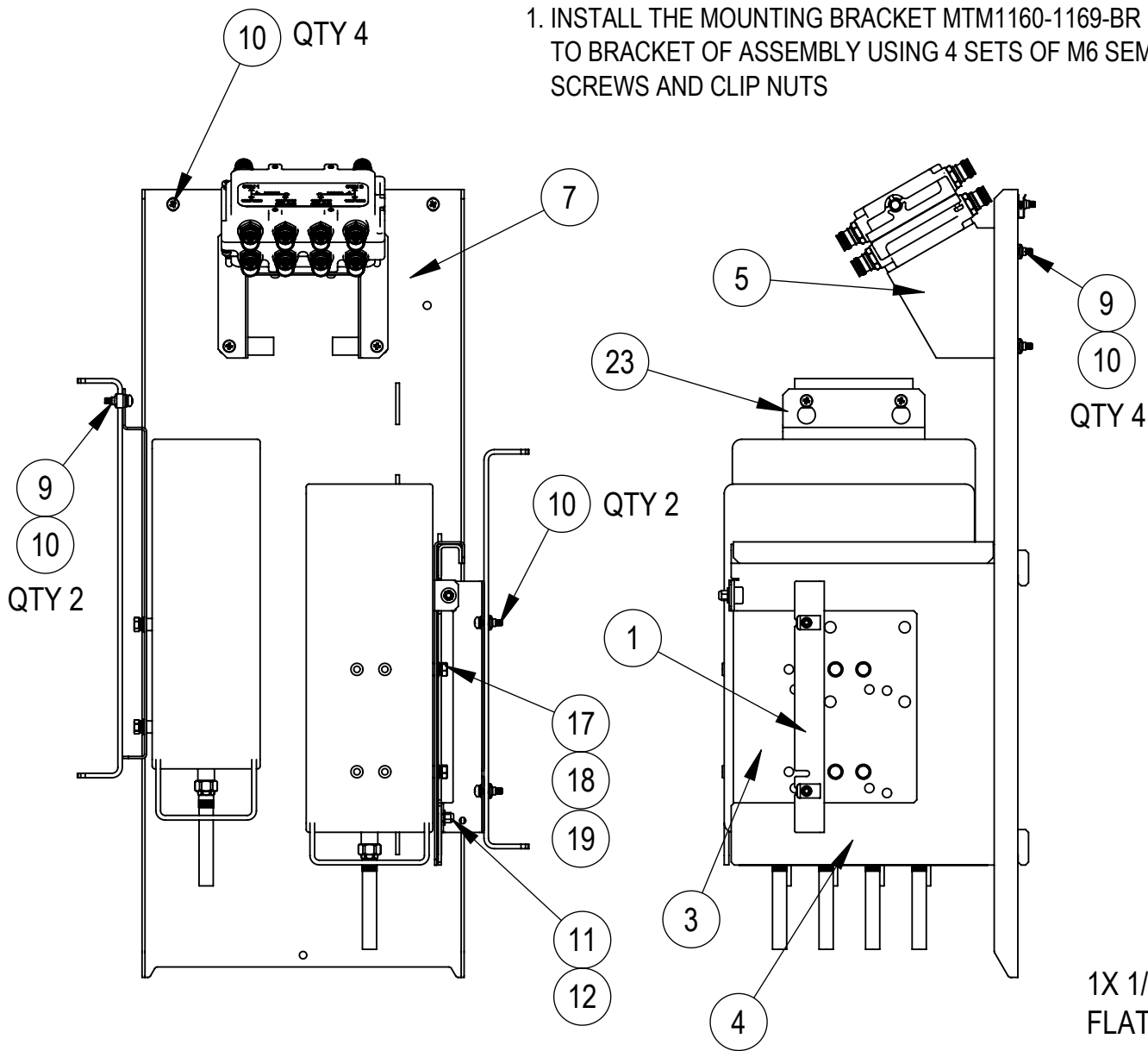

10 QTY 4

7

5

9

10 QTY 4

9

10 QTY 2

1

17

18

19

11

12

3

4

1X 1/4" NUT AND FLAT WASHER

4471

BRACKET MTM1160-1141-BR

BRACKET MTM1193-1680-BR (IN IP20)

BRACKET MTM1221-4009-BR

2X M6 CLIP NUT

BRACKET MTM1160-1162-BR

4461

4471

BRACKET MTM1160-1141-BR

IP20 VIEW

BRACKET MTM1160-8842 (IN D-MODULE) OR MTM1160-1542 (IN PB20)

2X M6 HARDWARE

2X M6 CLIP NUT

BRACKET MTM1193-1680-BR (IN IP20)

2X M6 HARDWARE

2X M6 CLIP NUT

BRACKET MTM1160-8841 (IN D-MODULE) OR MTM1160-1541 (IN PB20)

2X M6 HARDWARE

2X M6 CLIP NUT

2X M6 HARDWARE

2X M6 CLIP NUT

2X M6 HARDWARE

PB20 OR D-MODULE VIEW

BOM FOR 4471+ 4461 + QUAD DIPLEXER SDX1926Q-43 INSTALLATION

ITEM NO.	PART NUMBER	DESCRIPTION	QTY.
1	MTM1193-1111-BR	BRKT SM SPRT 4 HOOK & HANG PB20GA-0.375	1
3	MTM1160-1141-BR	BRKT SLIDE HANGER ERCISON PB20GA	1
4	MTM1160-1162-BR	BRACKET, HANGING RAIL MOVEABLE PB20GA	1
5	MTM1160-1167-BR	BRKT DIPLEX MNTG TOP/ANGLE PB20GA	1
7	MTM1160-1169-BR	BRKT MAIN HK & HANG REAR PLT PB20GA	1
9	460143456	CLIP NUT, M6, 316 SST	6
10	100117-4	FA,SEMS,PH,XRES,M6X25,SST,PASS	12
11	SNYL02	1/4" SS NYLOCK HEX NUT	3
12	SWF-02	FLAT WASHER, 1/4" SS	3
17	MTC9415	M8 X 25mm HEX BOLT SS	8
18	MTC9418	M8 LOCK WASHER SS	8
19	MTC9419	M8 FLAT WASHER SS	8
23	MTM1221-4009-BR	MOUNTING BRACKET, ERC E-4461/4471	1

STEP 4 :
MTM1160-1141-BR (4471)

1. HANG THE MOUNTING BRACKET MTM1160-1141-BR TO THE MOUNTING BRACKET MTM1160-1162-BR AND LOCK THE SIDE USING 1 SET OF 1/4" NUT AND FLAT WASHER

STEP 5 :
MTM1221-4009-BR(4461)

1. HANG THE MOUNTING BRACKET MTM1221-4009-BR TO THE BRACKET MTM1193-1680-BR OF THE IP20, TIGHTEN THEM DOWN USING 2 SETS OF M6 BOLTS AND NUTS
1. INSTALLED ABOVE SUB-ASSY TO POLE FRAME (PB20, D-MODULE & IP20)

E15: 4471 + 4461 QUAD DIPLEXER SDX1926Q-43 INSTALLATION

EQUIPMENT INSTALLATION SEE SHEET 4 & 5
TORQUE ALL TO SPEC

Confidential



TITLE KIT ERICSSON INSTALL INTO PB20GA-0.375			
SIZE C	SCALE 1:10	DOCUMENT NO. MTM1193-1101-AMK-E	
DRAWING			SHEET
VERSION 04	STATUS RE	REVISION E	21 OF 21