

- 1.0 GENERAL NOTES
- 1.1 ALL METRIC DIMENSIONS ARE IN BRACKETS [X. X]
- 1.2 FOR PATENT INFO: <https://www.adwpat.com>

- 2.0 DESIGN NOTES
- 2.1 ANY HAZARDS OR OBSTRUCTIONS TO THE CLIMBING FACILITY AND SAFETY CLIMB MUST BE IDENTIFIED PRIOR TO INSTALLING THE APPURTENANCE. ADDITIONAL PRODUCTS MAY BE REQUIRED TO MAINTAIN THE INTEGRITY OF THE SAFETY CLIMB. DURING INSTALLATION, TEMPORARY AND/OR PERMANENT PRECAUTIONARY MEASURES SHOULD BE TAKEN TO PRESERVE THE CLIMBING FACILITY AND/OR SAFETY CLIMB.

2.2 OPTIONAL TIE BACK KIT. RECOMMENDED WHEN SKEW ADAPTOR EXTENSION LENGTH IS GREATER THAN 36".

2.3 ENSURE THE TIE-BACK IS CONNECTED FROM THE SKEW ADAPTOR TO THE ADJACENT FACE PIPE, DO NOT CROSS OVER ANOTHER SKEW ADAPTOR. IT IS RECOMMENDED TO MAXIMIZE THE DISTANCE TO ENHANCE THE STRUCTURAL STRENGTH OF THE ASSEMBLY.

2.4 THE DATA PROVIDED IN THE TABLE 2 IS BASED ON THE ANDREW MP-PP13M-12-96 AND ANDREW MP-PP13M-12-126 PLATFORMS. FOR MORE DETAILED INFORMATION ABOUT THESE PLATFORMS, PLEASE VISIT THE ANDREW WEBSITE.

2.5 AN A&E EVALUATION IS REQUIRED FOR ANY LEGACY MOUNT USING THIS SKEW ADAPTOR.

2.6 IN ORDER TO PREVENT THE INTERNAL SPACE OF PLATFORM FROM BEING ENCROACHED UPON, THE EXCESS LENGTH IS ALLOWED TO BE CUT OFF.

3.0 MANUFACTURING/SPECIAL REQUIREMENTS

3.1 TIGHTEN ALL BOLTS SECURING FLAT PLATES BY THE TURN-OF-NUT METHOD. TIGHTEN ALL U-BOLTS USING TURN-OF-NUT METHOD WITH ATTENTION TO LEAVE EQUAL DISTANCE AND EQUAL FORCE ON EACH LEG OF THE U-BOLT.

4.0 TEST

5.0 PACKAGING

5.1 PACKAGING SHALL MEET ANDREW REQUIREMENTS PER DOCUMENT IS-PL-3005.

5.2 PRINTED DOCUMENT TO BE PLACED INSIDE POLYBAG AND THEN IN SHIPPING CONTAINER.

5.3 EXTRA HARDWARE MAY BE SUPPLIED, BAGGED AND SHIPPED.

REVISIONS			
REV.	DESCRIPTION	DATE	APPROVED
A	INITIAL RELEASE	JL1183 01JUL24	CB1094 40199307CMO
B	SHEET1: ADDED NOTE 2.2-2.6; UPDATED PACK VIEW ADDED SHEET 2 & 3 TO SHOW MORE DETAILS	JL1183 09JUL24	CB1094 40199307CMO
C	UPDATE PACKING VIEW	JL1183 26FEB25	CB1094 50101539AMO

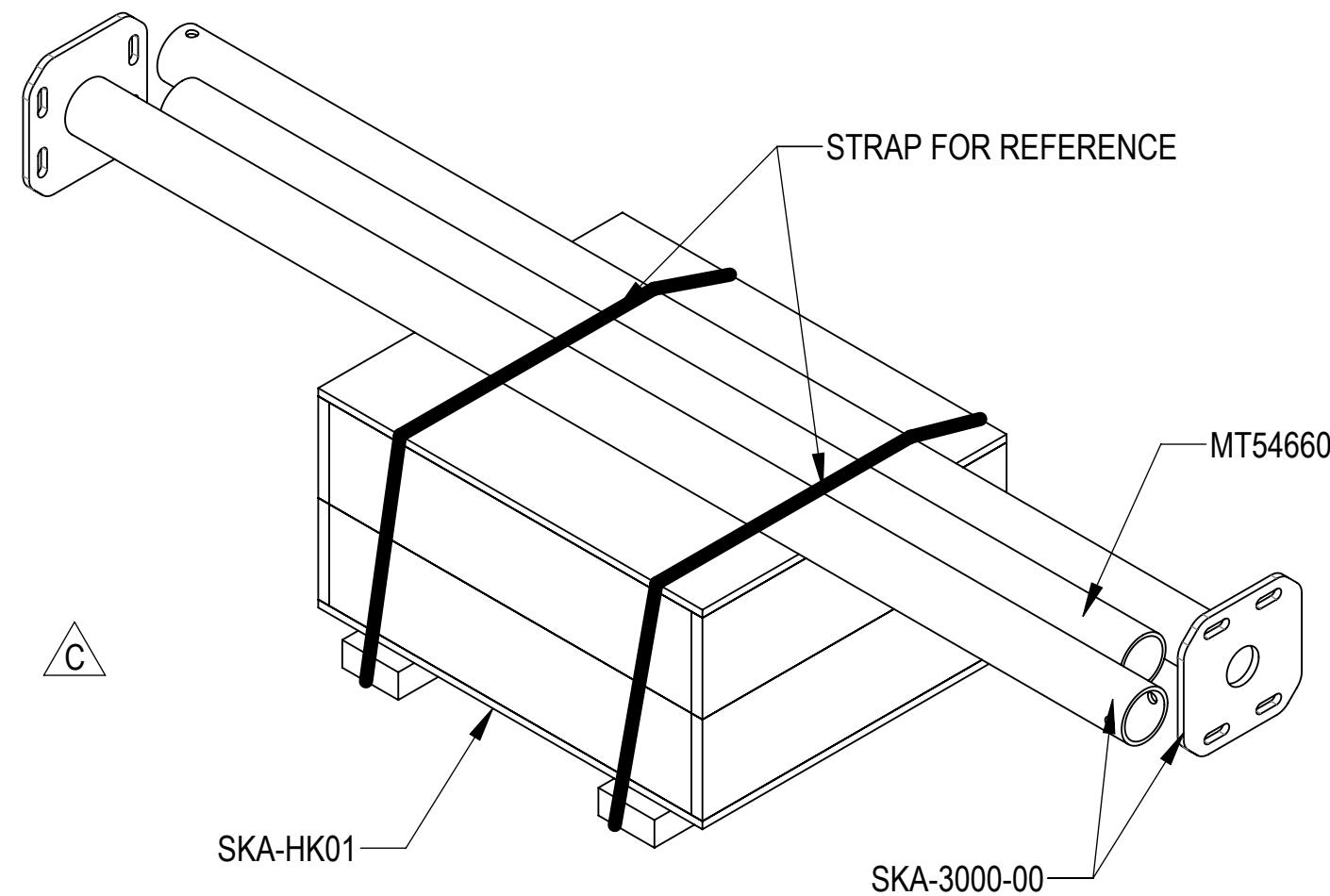



PACKING SHOWN

COMPONENT PART NUMBERS PROVIDED FOR ASSEMBLY PURPOSES;
INDIVIDUAL COMPONENTS MAY BE SHIPPED AS PARTS WITHIN AN INCLUDED KIT.

ITEM NO.	PART NUMBER	DESCRIPTION	QTY.	WEIGHT	NOTE NO.
1	MT54660	2.875" O.D. X 60 PIPE	1	27.39 LBS	
2	SKA-2000-00	WELDMENT, SKEW ADAPTOR BRACKET	2	30.41 LBS	
3	SKA-3000-00	WELDMENT, SKEW ADAPTOR SLIDING ARM	2	36.72 LBS	
4	GUB-53060	5/8" X 3" X 6" GALV U-BOLT	4	1.26 LBS	
5	GB-04365	1/2" X 3-3/4" GALV BOLT KIT	2	0.25 LBS	
6	GWF-04	1/2" GALV FLAT WASHER	2	0.04 LBS	
7	GUB-4352	1/2" X 3" X 5-1/4" GALV U-BOLT	4	0.71 LBS	
8	SEE TABLE 1	-	4	-	

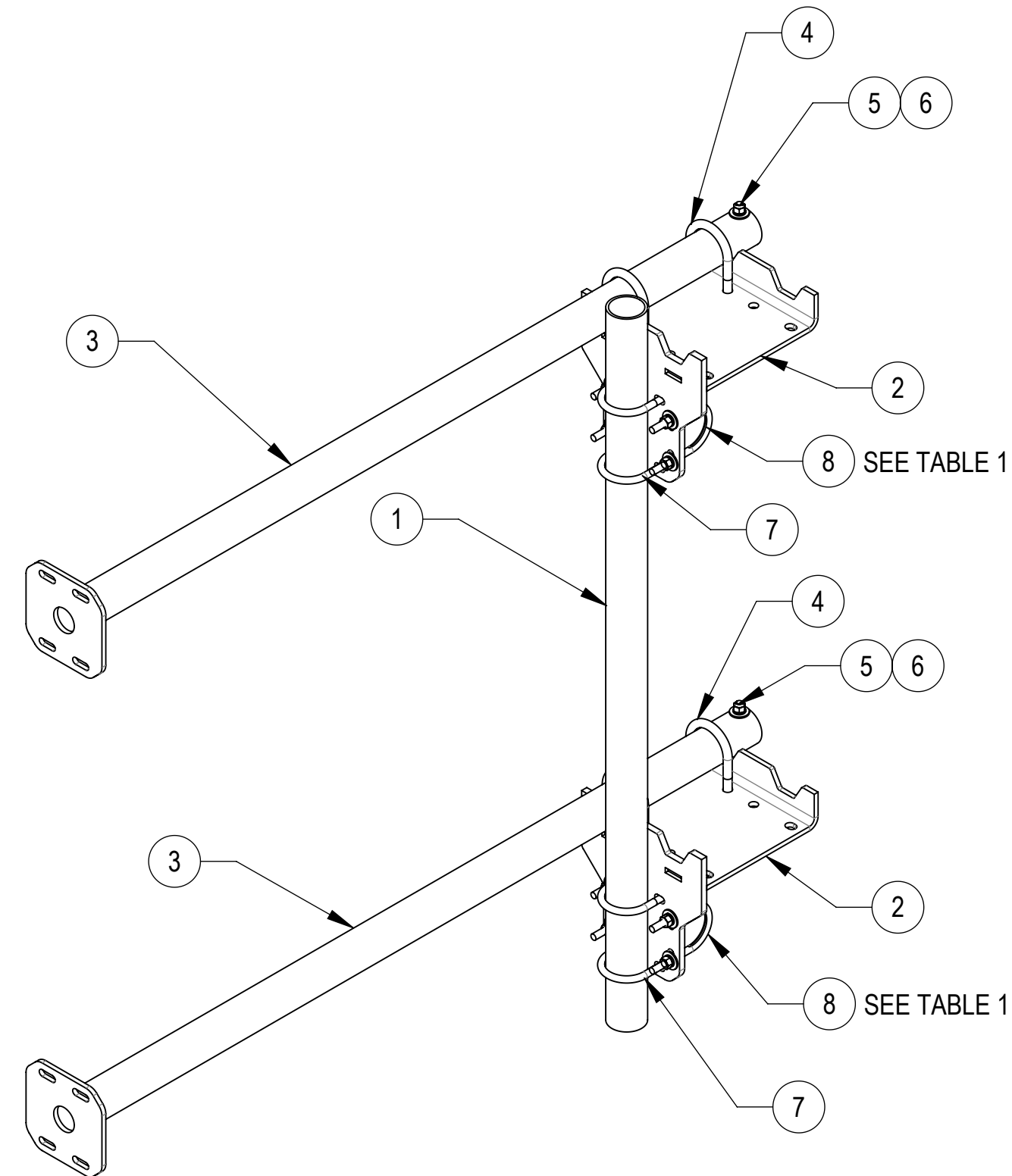
FACE PIPE	U-BOLT
∅ 2-3/8"	GUB-4240
∅ 2-7/8"	GUB-4352
∅ 3-1/2"	GUB-4355





ANDREW® an Amphenol company

TOLERANCES		SAP MATERIAL MASTER	
1 PLACE .X[X] ± 0.2[6.3]	3 PLACE .XXX[X] ± 0.060[1.5]	860678540	
2 PLACE .XX[X] ± 0.12[3.0]	ANGLES ± 2°		
FINISH		MATERIAL	
UNLESS OTHERWISE SPECIFIED DIMENSIONS ARE IN INCHES INTERPRET PER ANSI Y 14.5M-1994		NAME	DATE
		CE JL1183	01JUL24
		RW YX1027	07/14/2025
		AD YMENG	07/14/2025
		RE YMENG	07/14/2025
		ECN 50101539AMO	
TITLE		SCALE	
SKEW ADAPTOR, 13', 10-20 DEGREE		1:8	
		DOCUMENT NO.	
		860678540	
SIZE	Auth Group	INSL	MODEL
C			
		DRAWING	
VERSION	STATUS	REVISION	VERSION
02	RE	C	02
		STATUS	
		RE	
		REVISION	
		C	
			SHEET
			1 OF 3

Confidential

4

3



2

1

OPTIONAL ACCESSORIES
 (ALL THE ACCESSORY ITEMS TO BE PURCHASED SEPARATELY)

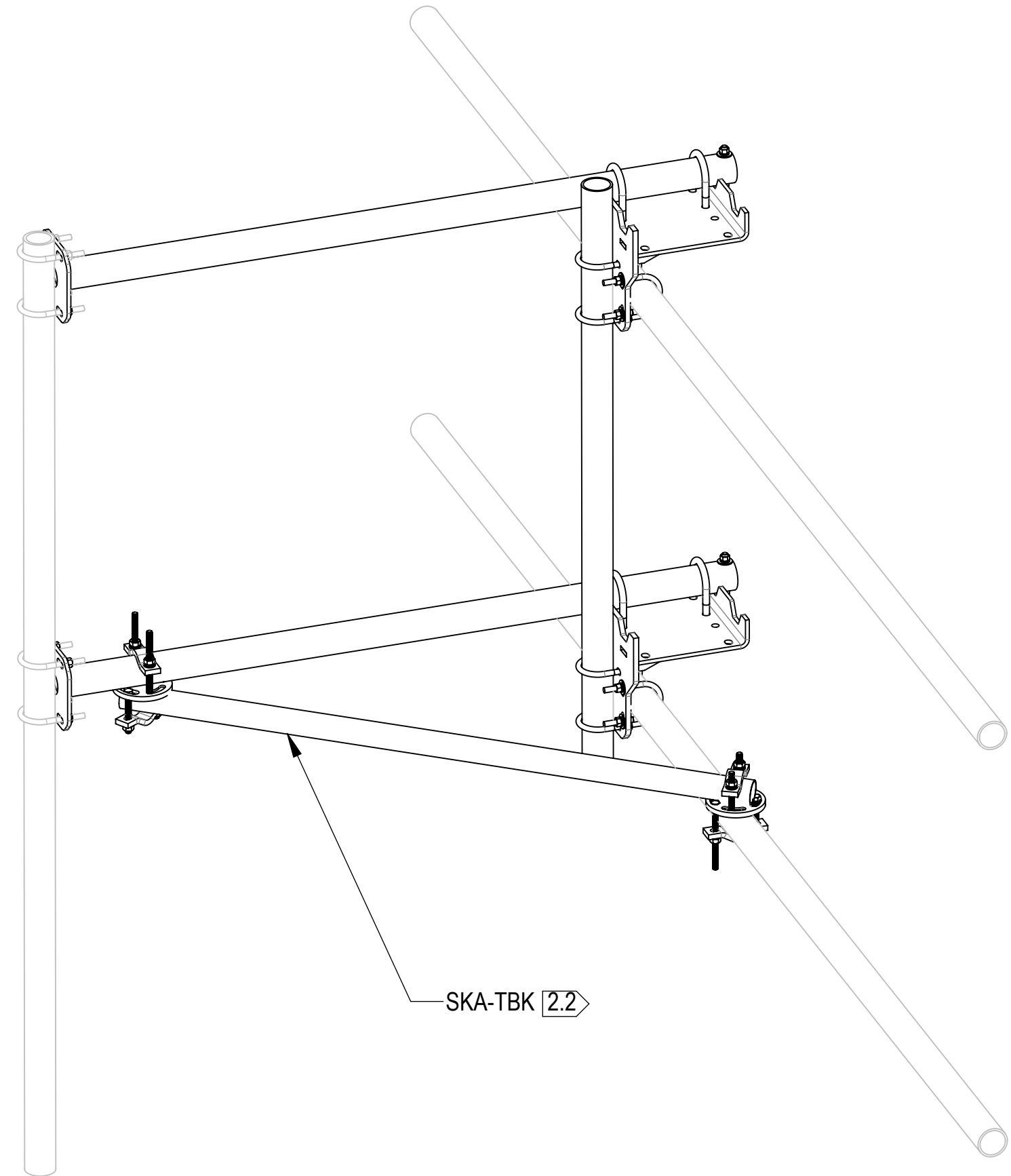
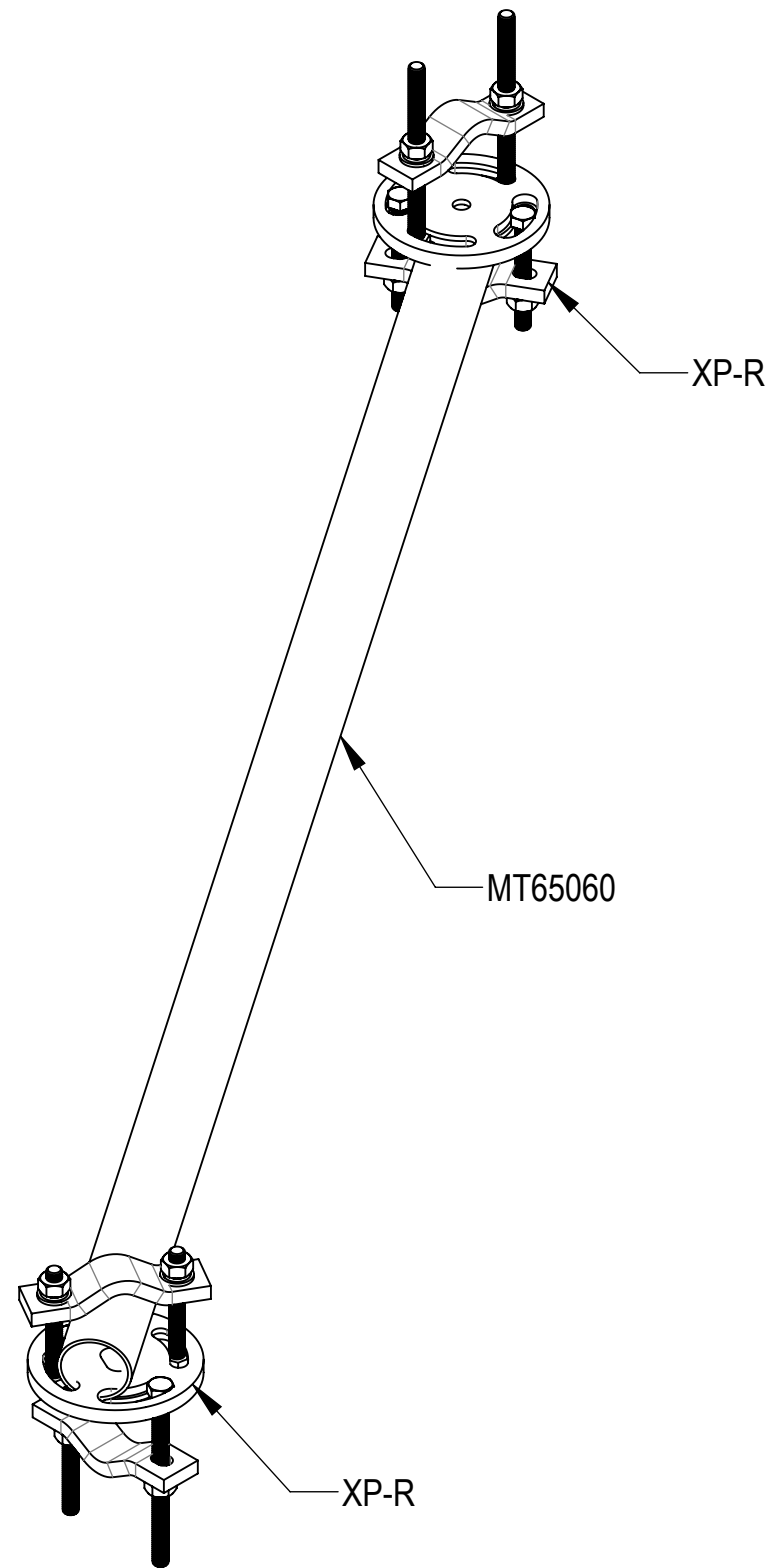
TIE-BACK KIT: SKA-TBK

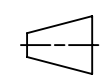

				
TITLE				
SKEW ADAPTOR, 13', 10-20 DEGREE				
SIZE	SCALE	DOCUMENT NO.		
C	1:8	860678540		
 	DRAWING			SHEET
	VERSION	STATUS	REVISION	
	02	RE	C	

Confidential

4

3

2

1

ATTACHED TO PLATFORM

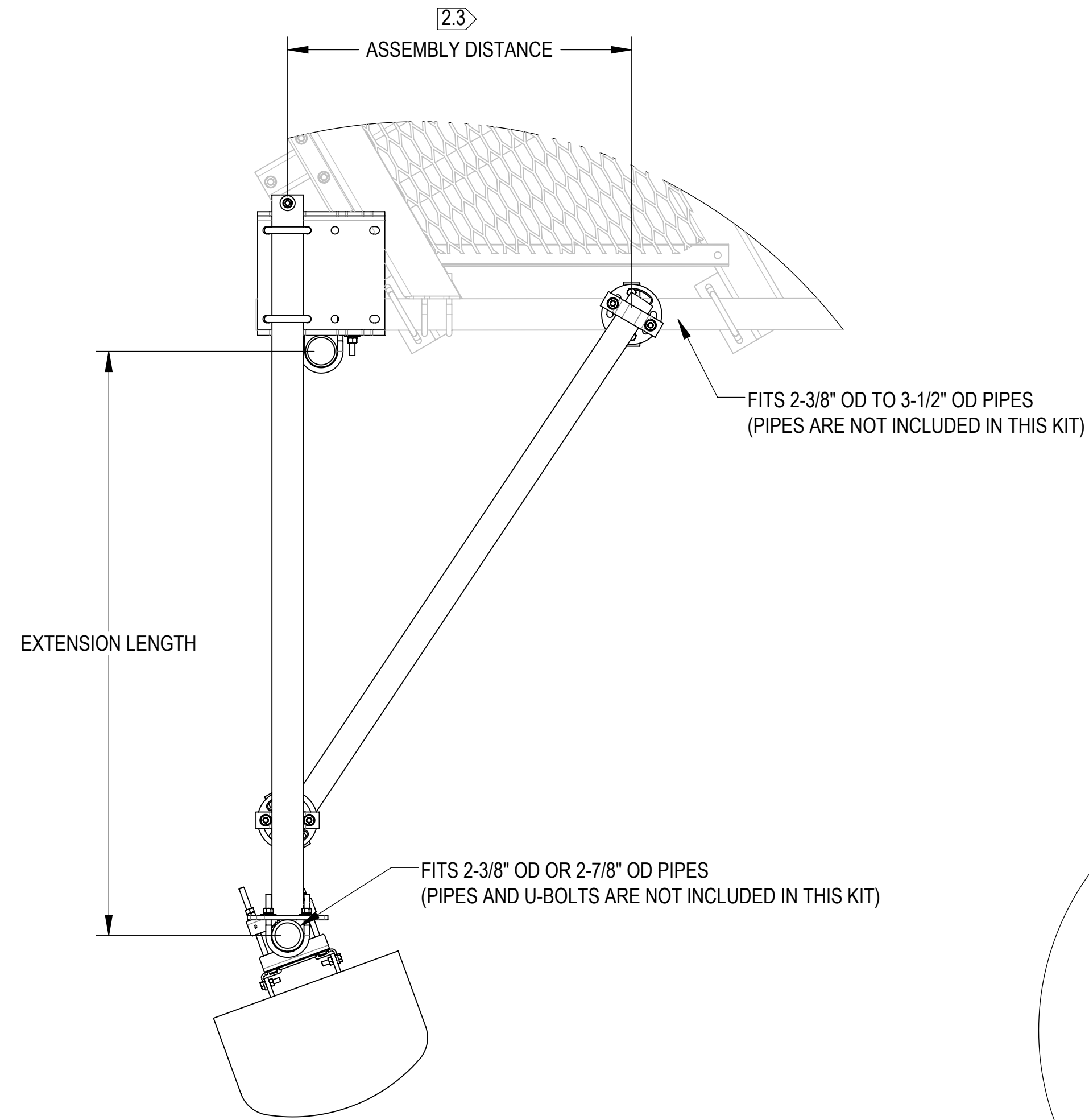

DETAIL A
SCALE 1 : 10

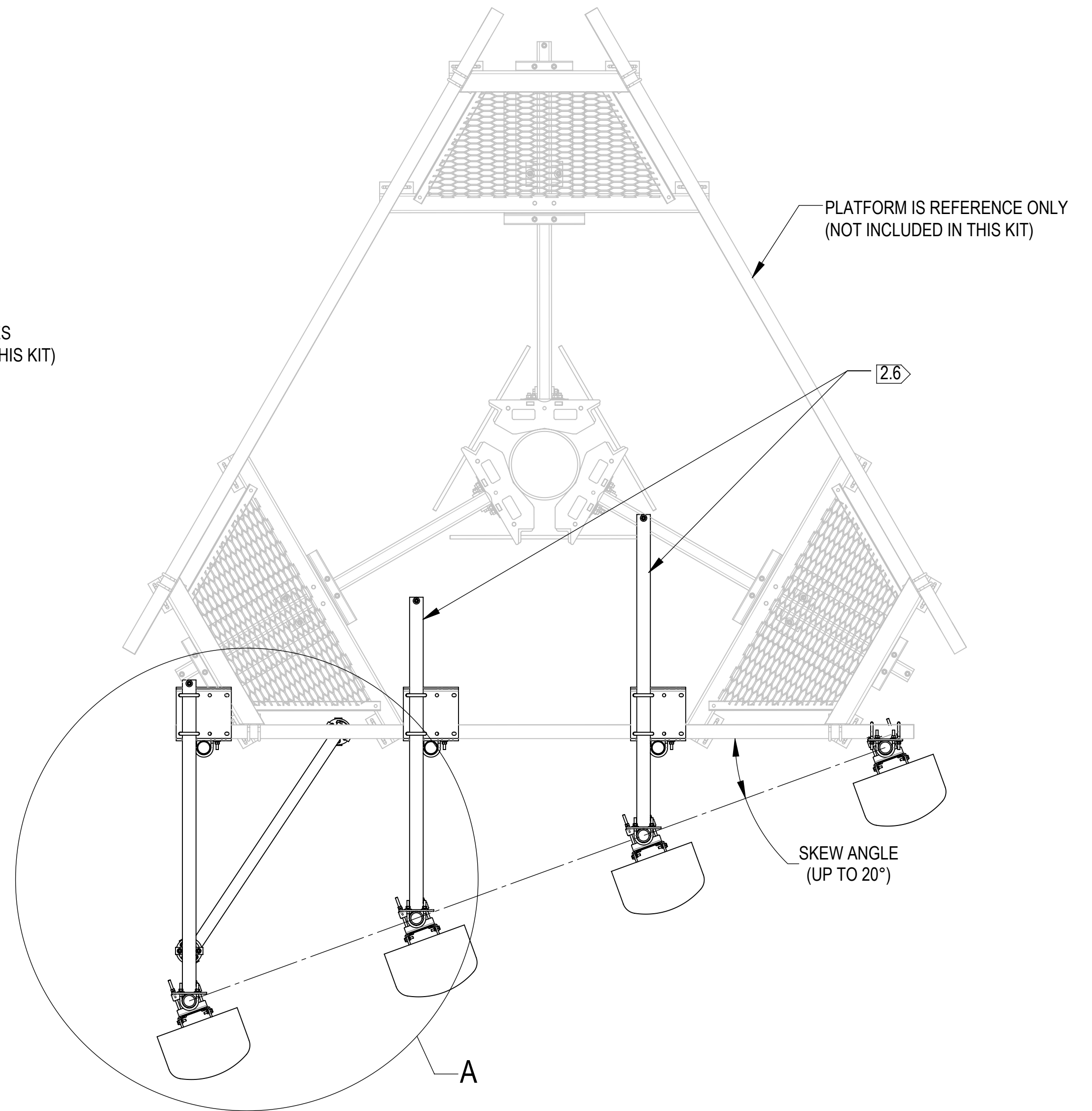

TABLE 2: LOAD CAPACITY OF PLATFORM WITH SKEW ADAPTOR EXTENSIONS AT DIFFERENT SKEW ANGLES

SKEW ANGLE	EXTENSION LENGTH	TIE-BACK REQUIRED	PLATFORM M-RATING
0°	NO EXTENSION	NO	M2350R(3400)-4[6]
12°	UP TO 31.3" EXTENSION	NO	M1900R(2600)-4[6]
16°	UP TO 42.2" EXTENSION	YES	M1900R(2400)-4[6]
20°	UP TO 53.5" EXTENSION	YES	M1800R(1950)-4[6]

ANDREW an Amphenol company

TITLE
SKEW ADAPTOR, 13', 10-20 DEGREE

SIZE C	SCALE 1:8	DOCUMENT NO. 860678540
DRAWING		SHEET
VERSION 02	STATUS RE	REVISION C
3 OF 3		

Confidential