

4

3

2

1

1.0 GENERAL NOTES

- 1.1 ALL METRIC DIMENSIONS ARE IN BRACKETS [X. X]
- 1.2 FOR PATENT INFO: <https://www.adwpat.com>

2.0 DESIGN NOTES

- 2.1 THIS KIT PROVIDES ADDITIONAL CLEARANCE BETWEEN RING MOUNT WELDMENTS (SUPPLIED SEPARATELY) AT THE PERIMETER OF THE MOUNTING POLE.

3.0 MANUFACTURING/SPECIAL REQUIREMENTS

- 3.1 INSTALL ALL RING MOUNT SECTIONS TO BE LEVEL AND EQUALLY SPACED
- 3.2 TIGHTEN ALL BOLTS SECURING FLAT PLATES BY THE TURN-OF-NUT METHOD. TIGHTEN ALL NUTS SECURING THREADED RODS TO A SNUG TIGHT CONDITION, WITH ATTENTION TO LEAVE EQUAL DISTANCE AND EQUAL FORCE ON EACH LEG OF THE THREADED ROD. SNUG TIGHT IS DEFINED AS THE CONDITION OBTAINED WITH A FEW IMPACTS OF AN IMPACT WRENCH OR THE FULL EFFORT OF AN IRONWORKER USING AN ORDINARY SPUD WRENCH

4.0 TEST

5.0 PACKAGING

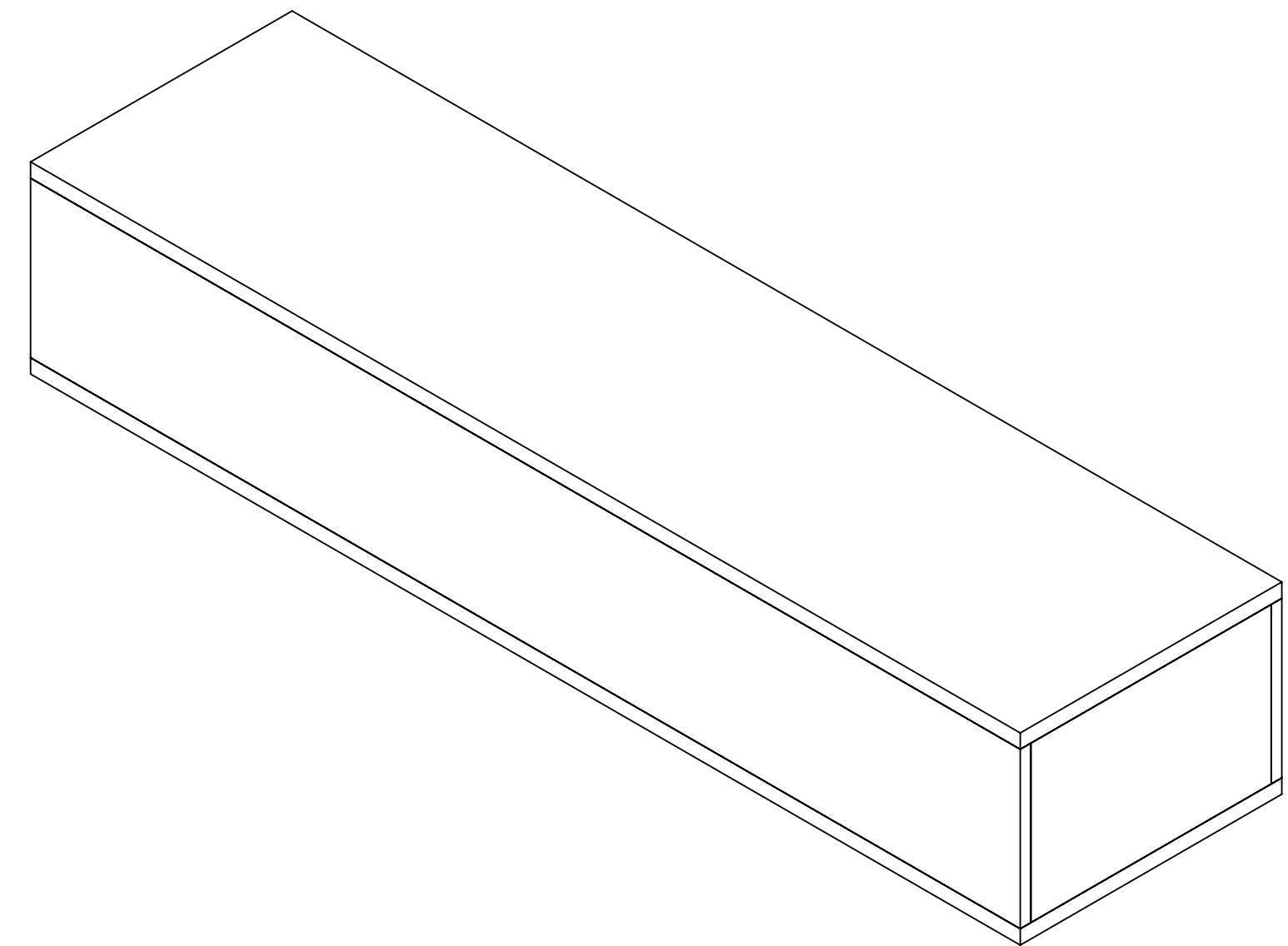
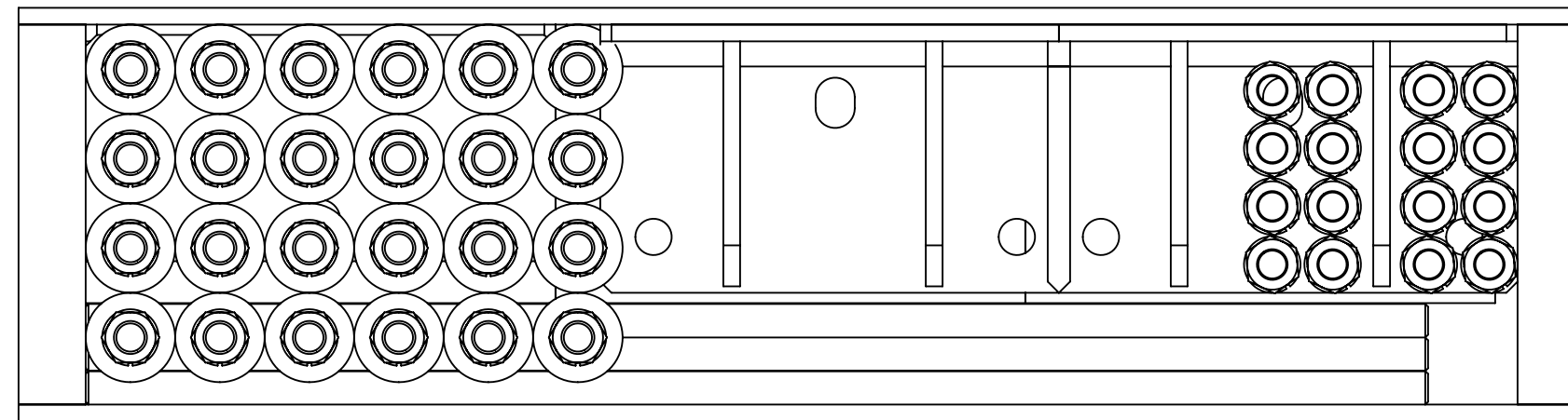

- 5.1 PACKAGING SHALL MEET ANDREW REQUIREMENTS PER DOCUMENT IS-PL-3005
- 5.2 PRINTED DOCUMENT TO BE PLACED INSIDE POLYBAG AND THEN IN SHIPPING CONTAINER
- 5.3 EXTRA HARDWARE MAY BE SUPPLIED, BAGGED AND SHIPPED

REVISIONS			
REV.	DESCRIPTION	DATE	APPROVED
A	INITIAL RELEASE	YX1027 21AUG24	AG1119 40201197CMO





ANDREW® an Amphenol company

TOLERANCES		SAP MATERIAL MASTER						
1 PLACE .X[X] ± 0.2[6.3]	3 PLACE .XXX[X] ± 0.060[1.5]	MC-RM-EXT						
2 PLACE .XX[X] ± 0.12[3.0]	ANGLES ± 2°							
FINISH		MATERIAL						
UNLESS OTHERWISE SPECIFIED DIMENSIONS ARE IN INCHES INTERPRET PER ANSI Y 14.5M-1994		NAME	DATE	EXT PLATE KIT, RING MOUNT				
		CE YX1027	21AUG24					
		RW LL1090	07/15/2025					
		AD YMENG	07/15/2025					
		RE YMENG	07/15/2025					
ECN 40201197CMO		SCALE 1:4	DOCUMENT NO. MC-RM-EXT					
SIZE	Auth Group	INSL	MODEL	DRAWING		SHEET 1 OF 3		
C	 	VERSION	STATUS	REVISION	VERSION		STATUS	REVISION
		00	RE	A	00		RE	A

DENSITY		lbs/in ³
MASS	139.14	lbs
VOLUME	1075.61	in ³
SURFACE AREA	5538.02	in ²
HEIGHT	10.5"	
LENGTH	49.5"	
WIDTH	43.6"	

Confidential

4

3

2

1

4

3

2

1

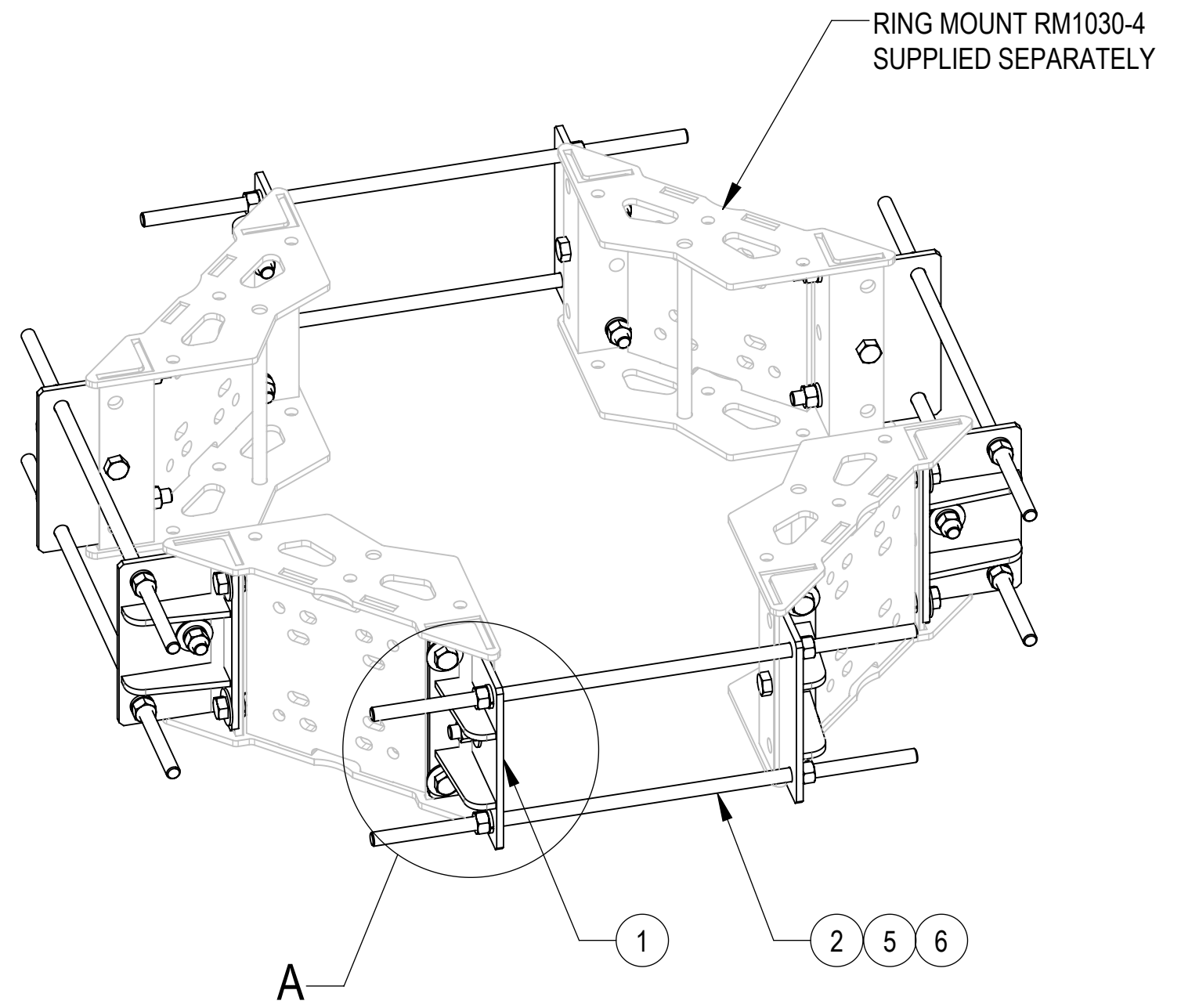
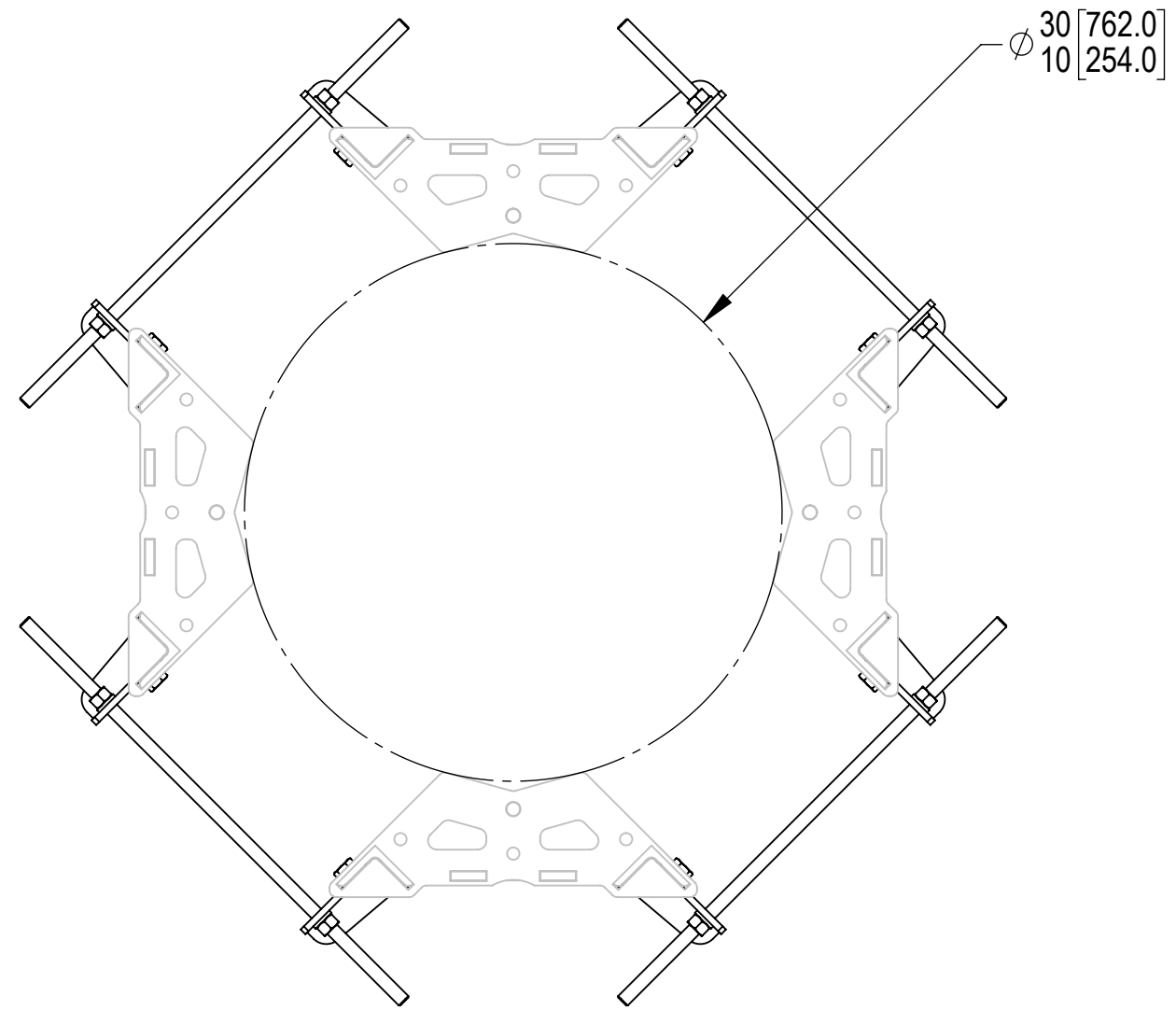

DO NOT REUSE OLD HARDWARE, NEW HARDWARE PROVIDED

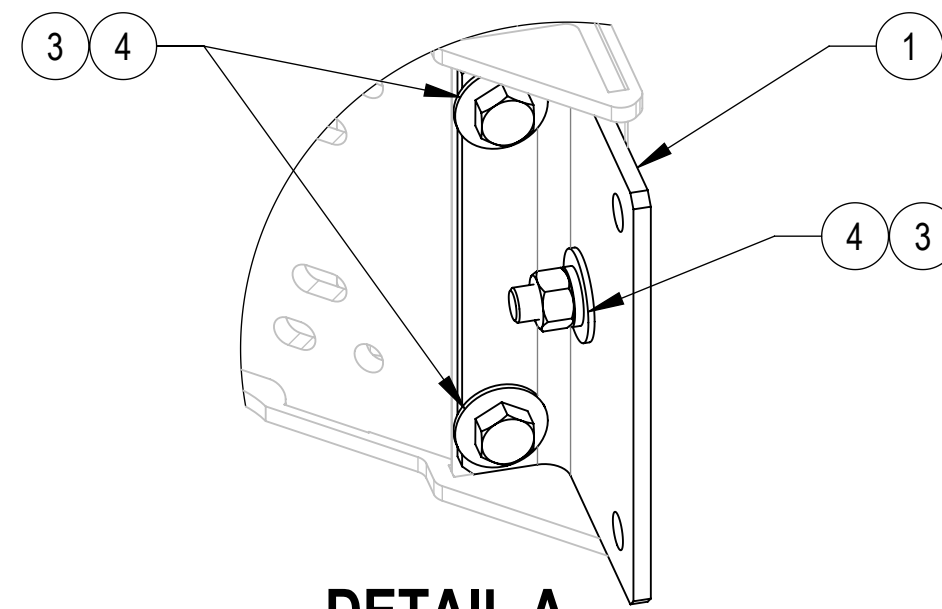
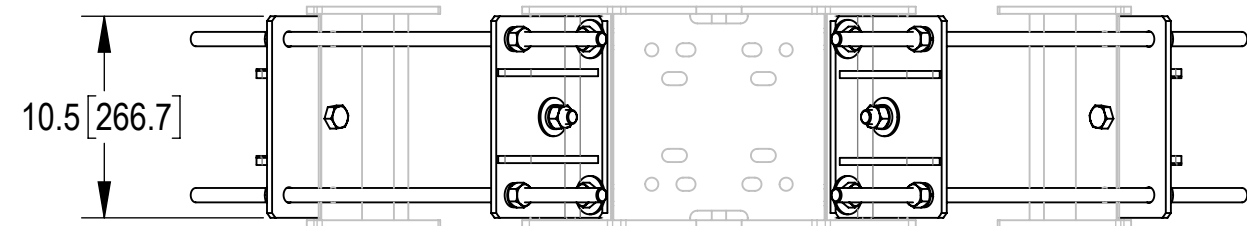

DETAIL A
SCALE 1:4

COMPONENT PART NUMBERS PROVIDED FOR ASSEMBLY PURPOSES;
INDIVIDUAL COMPONENTS MAY BE SHIPPED AS PARTS WITHIN AN INCLUDED KIT.

ITEM NO.	PART NUMBER	DESCRIPTION	QTY.	WEIGHT	NOTE NO.
1	RM1030320-00	WELDMENT, RING MOUNT EXTENSION	8	0.93 LBS	
2	MT38430B7	3/4" X 30" GALV THREADED ROD GRADE B7	8	3.73 LBS	
3	GB-0622A	3/4" X 2-1/4" GALV BOLT KIT (A325)	24	0.44 LBS	
4	GWF-06	3/4" GALV FLAT WASHER	24	0.10 LBS	
5	GWL-06	3/4" GALV LOCK WASHER	16	0.04 LBS	
6	GN-06	3/4" GALV HEX NUT	16	0.15 LBS	



TITLE EXT PLATE KIT, RING MOUNT					
SIZE C	SCALE 1:16	DOCUMENT NO. MC-RM-EXT			
		DRAWING			SHEET 2 OF 3
		VERSION 00	STATUS RE	REVISION A	

Confidential

4

3

2

1

4

3

2

1

D

D

C

C

B

B

A

A

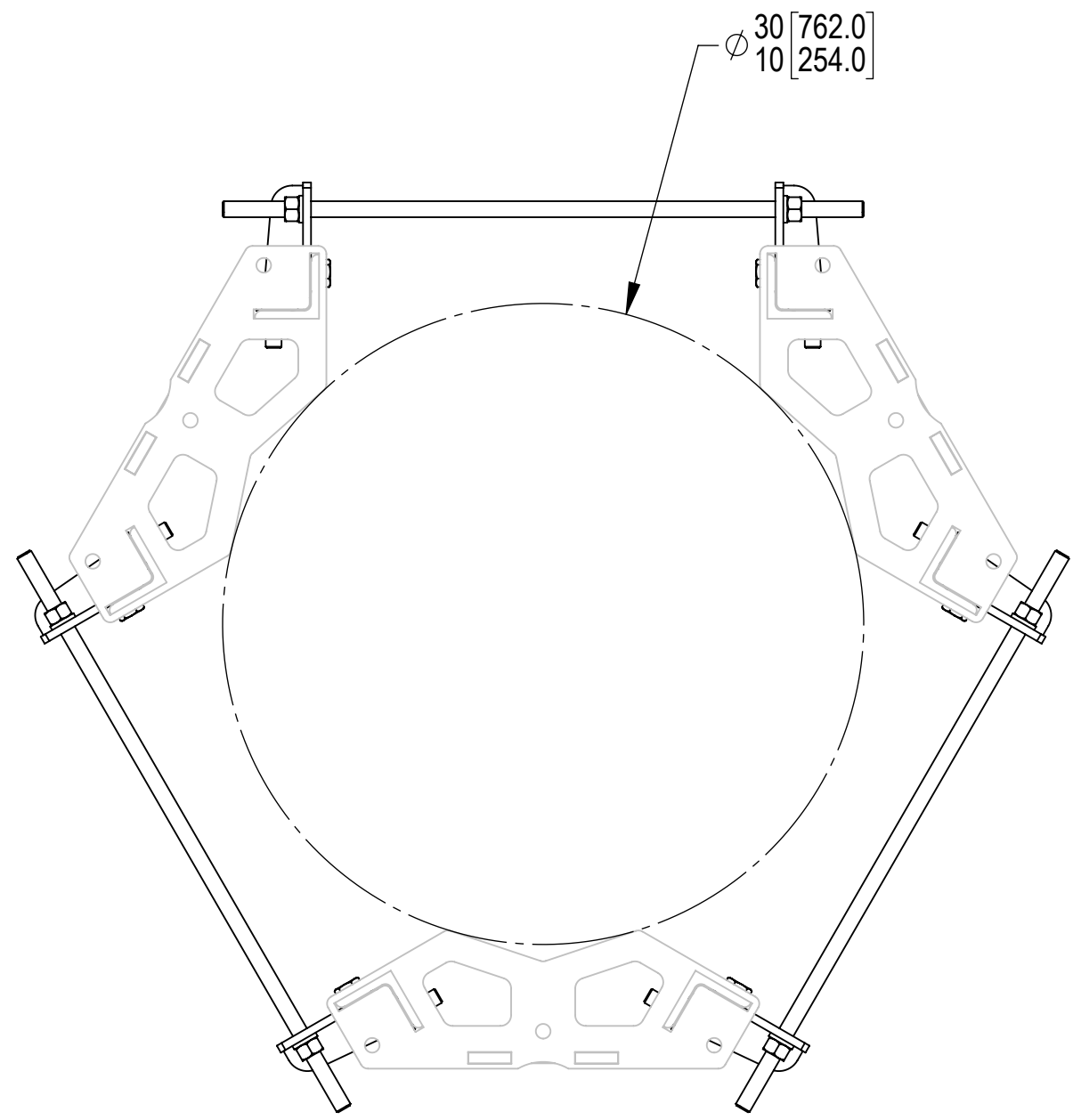

RING MOUNT RM1030-3
SUPPLIED SEPARATELY

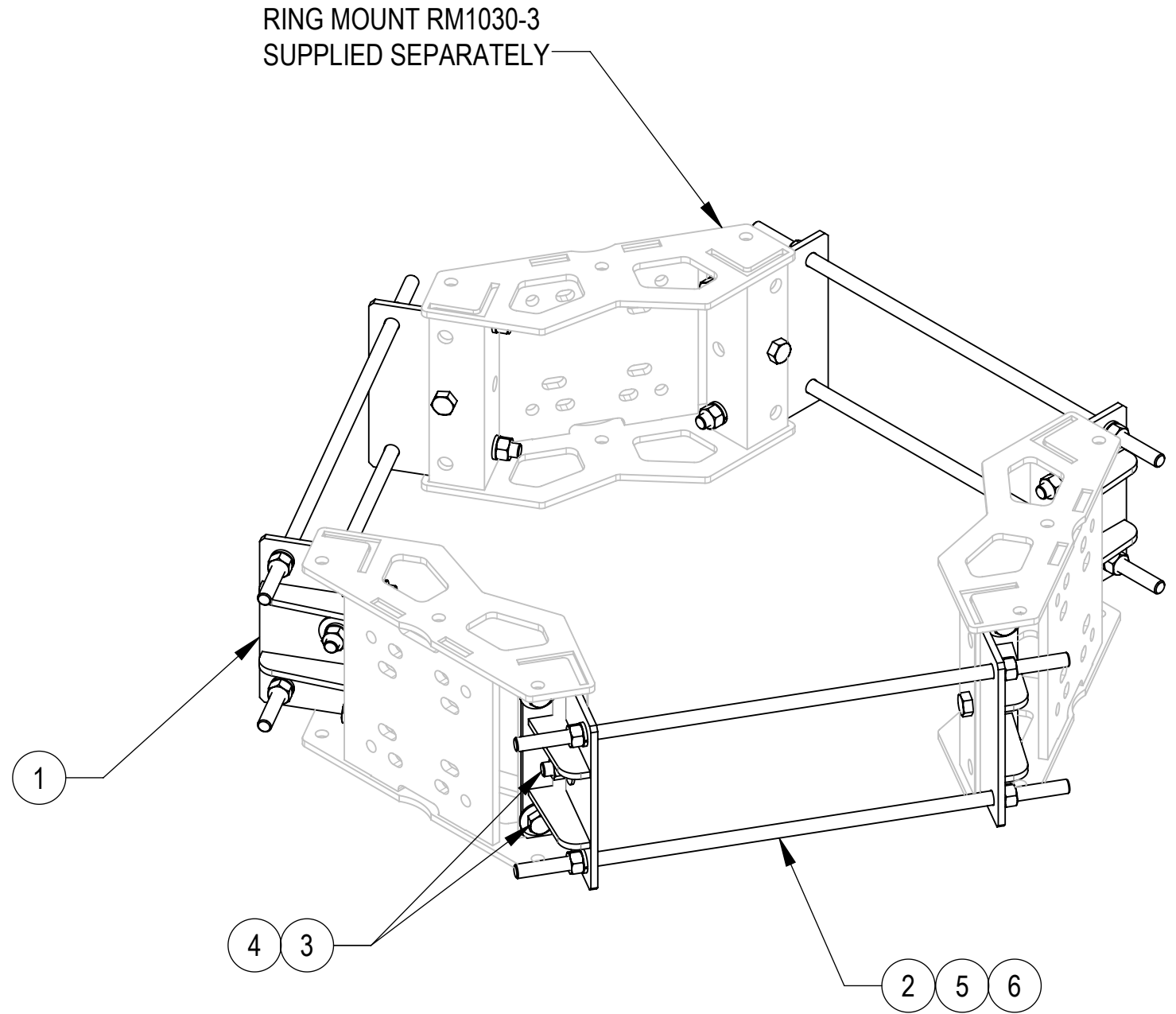

DO NOT REUSE OLD HARDWARE, NEW HARDWARE PROVIDED



TITLE				
EXT PLATE KIT, RING MOUNT				
SIZE	SCALE	DOCUMENT NO.		
C	1:12	MC-RM-EXT		
	DRAWING			SHEET
	VERSION	STATUS	REVISION	
	00	RE	A	

Confidential

4

3

2

1

