

- 1.0 GENERAL NOTES
 - 1.1 ALL METRIC DIMENSIONS ARE IN BRACKETS [X. X]
 - 1.2 FOR PATENT INFO: <https://www.adwpat.com>

- 2.0 DESIGN NOTES
- 3.0 MANUFACTURING/SPECIAL REQUIREMENTS

3.1 TIGHTEN ALL BOLTS SECURING FLAT PLATES BY THE TURN-OF-NUT METHOD. TIGHTEN ALL U-BOLTS USING TURN-OF-NUT METHOD WITH ATTENTION TO LEAVE EQUAL DISTANCE AND EQUAL FORCE ON EACH LEG OF THE U-BOLT.

- 4.0 TEST

- 5.0 PACKAGING

- 5.1 PACKAGING SHALL MEET ANDREW REQUIREMENTS PER DOCUMENT IS-PL-3005
- 5.2 PRINTED DOCUMENT TO BE PLACED INSIDE POLYBAG AND THEN IN SHIPPING CONTAINER
- 5.3 EXTRA HARDWARE MAY BE SUPPLIED, BAGGED AND SHIPPED

REVISIONS			
REV.	DESCRIPTION	DATE	APPROVED
K	UPDATED COMPONENT ON ITEM #1	HC 08JAN14	
L	NEW MOUNT WELDMENT	MSM 05MAR15	TP 8000007159
M	UPDATED FOR MOUNT WELDMENT CHANGE	YX1027 21AUG24	AG1119 40201197CMO

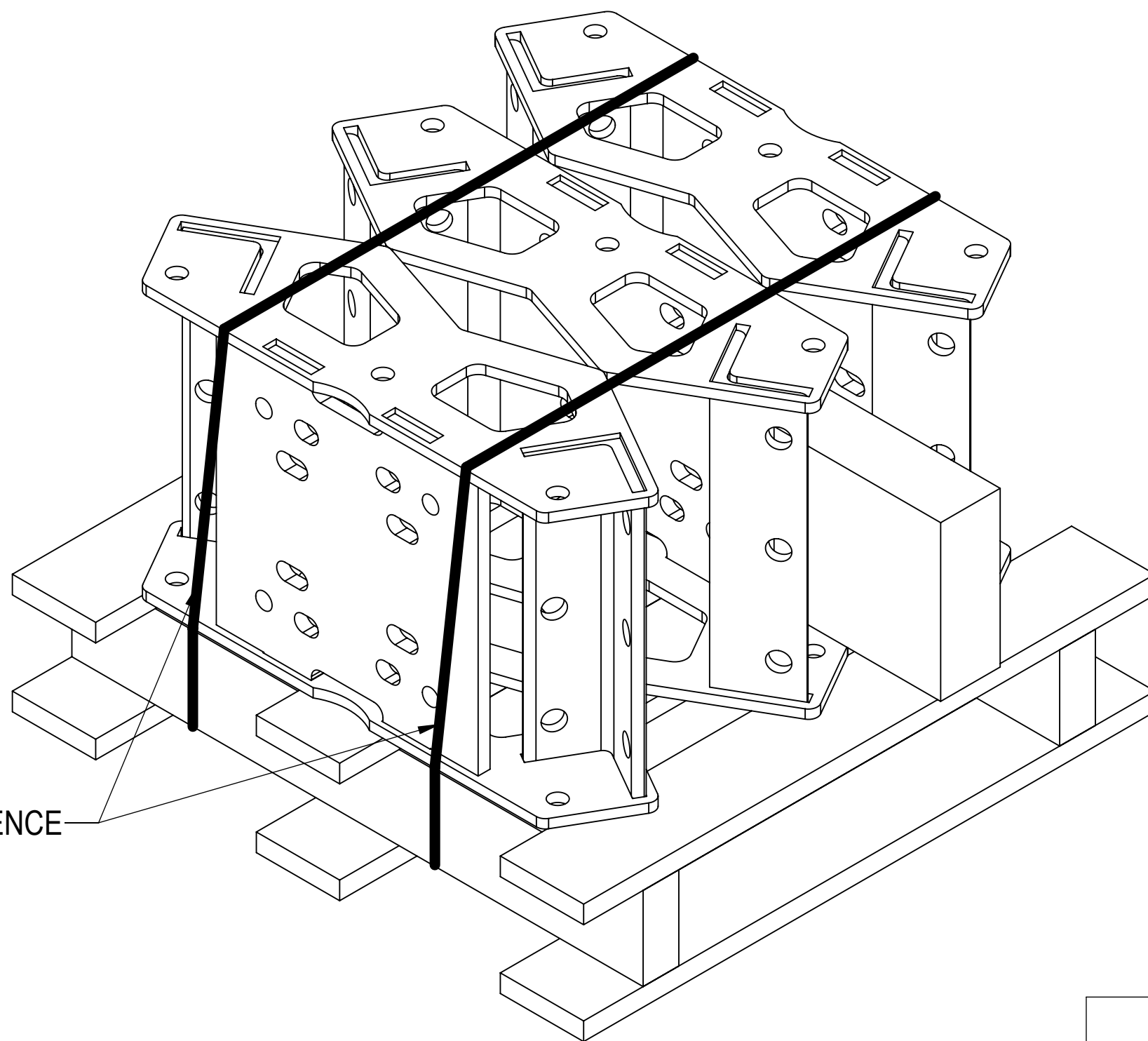

STRAP FOR REFERENCE



ANDREW® an Amphenol company

TOLERANCES		SAP MATERIAL MASTER	
1 PLACE .X[X] ± 0.12[3.0]	3 PLACE .XXX[X] ± 0.03[0.8]	MC-RM1030-3	
2 PLACE .XX[X] ± 0.06[1.5]	ANGLES ± 2°		
FINISH		MATERIAL	
UNLESS OTHERWISE SPECIFIED DIMENSIONS ARE IN INCHES INTERPRET PER ANSI Y 14.5M-1994		TITLE	
CE AW	30AUG04	10" - 30" OD RINGMOUNT	
RW LL1090	07/15/2025		
AD YMENG	07/15/2025		
RE YMENG	07/15/2025		
ECN 40201197CMO	SCALE 1:6	DOCUMENT NO. MC-RM1030-3	
SIZE Auth Group INSL	MODEL	DRAWING	
C	VERSION STATUS REVISION	VERSION STATUS REVISION	SHEET
	02 RE N 01 RE M		1 OF 2

DENSITY	lbs/in³
MASS	150.79 lbs
VOLUME	993.09 in³
SURFACE AREA	5044.70 in²
HEIGHT	15"
LENGTH	35"
WIDTH	33"

Confidential

4

3

2

1

D

D

C

C

B

B

A

A

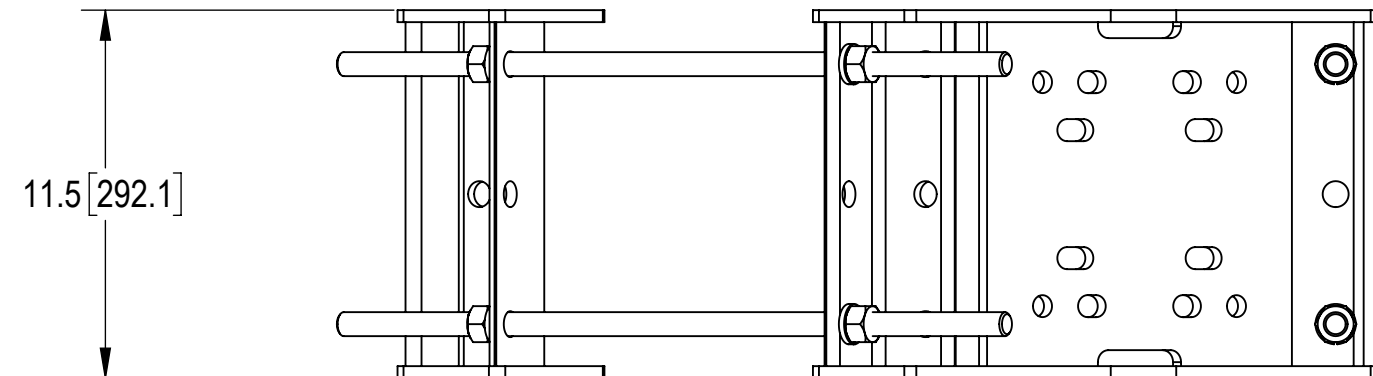
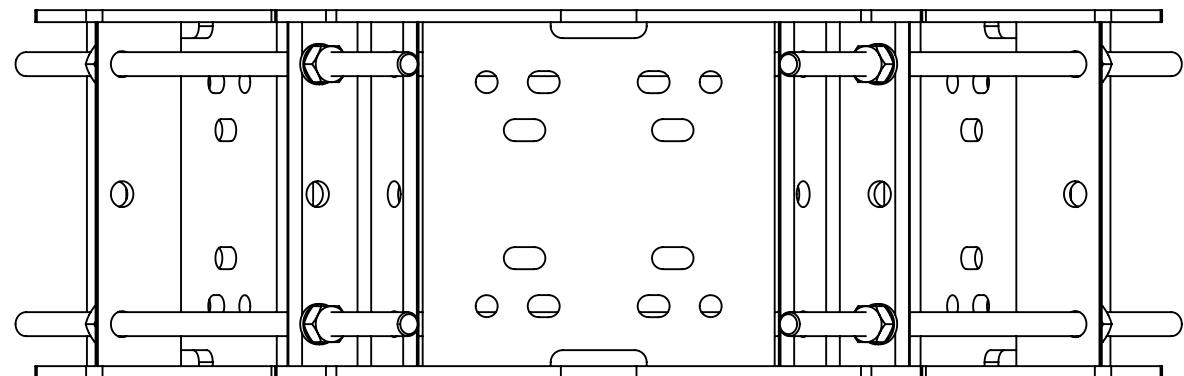
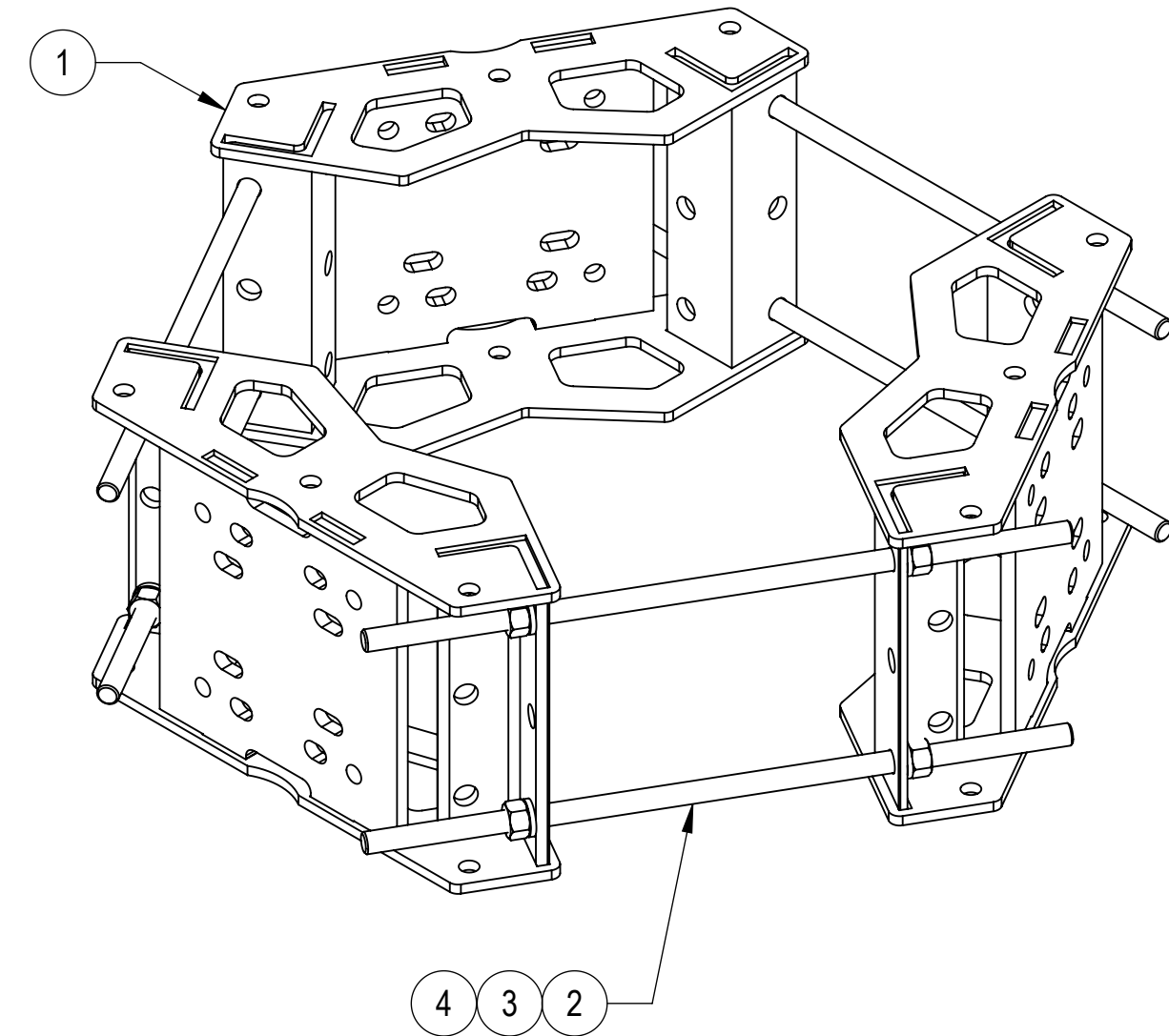
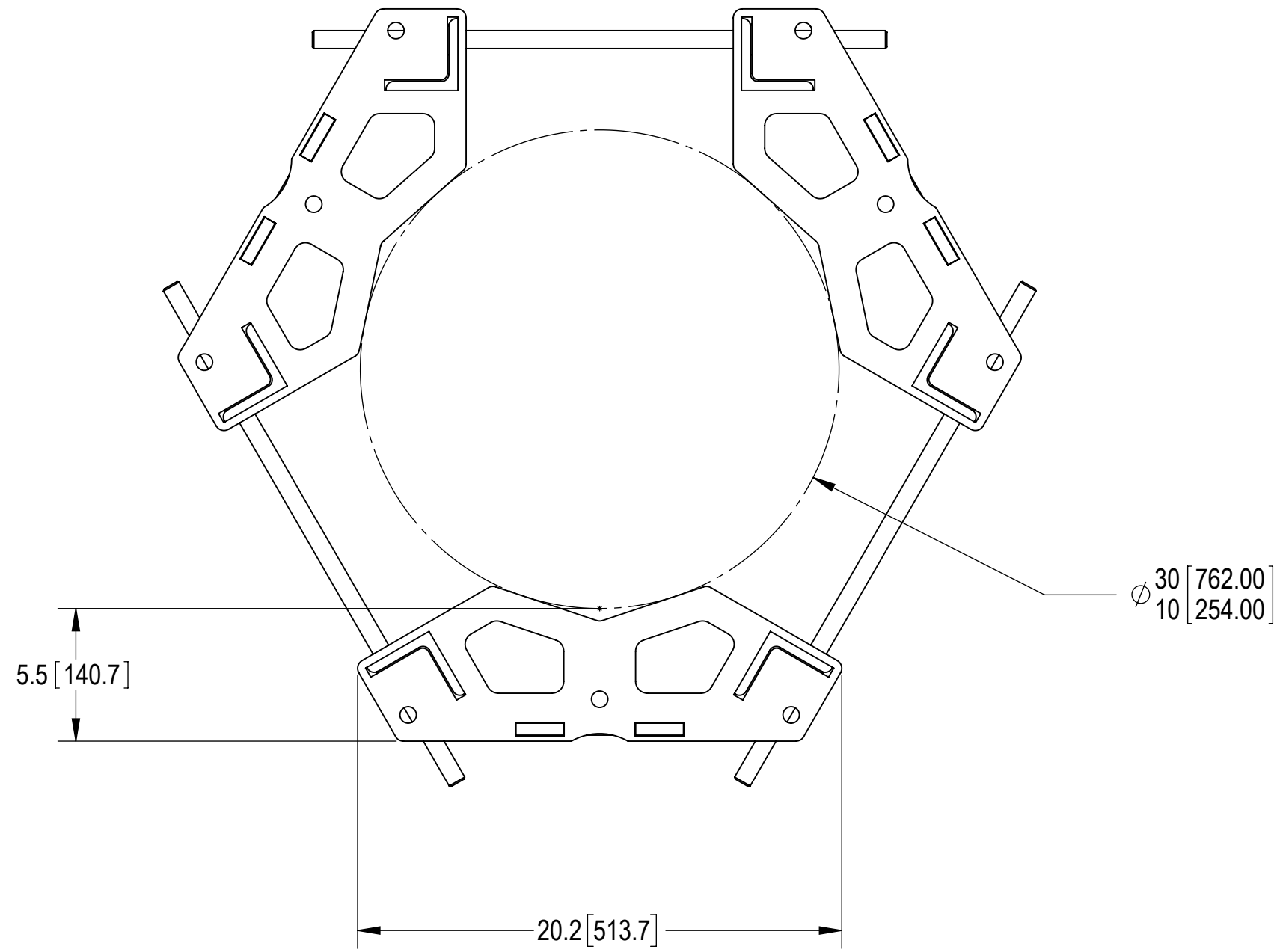

COMPONENT PART NUMBERS PROVIDED FOR ASSEMBLY PURPOSES;
INDIVIDUAL COMPONENTS MAY BE SHIPPED AS PARTS WITHIN AN INCLUDED KIT.

ITEM NO.	PART NUMBER	DESCRIPTION	QTY.	WEIGHT	NOTE NO.
1	RM1030305	10-30 3-SECTOR RM WLDMNT	3	43.54 LBS	
2	MT38424	3/4" X 24" GALV THREADED ROD	6	2.99 LBS	
3	GWL-06	3/4" GALV LOCK WASHER	12	0.04 LBS	
4	GN-06	3/4" GALV HEX NUT	12	0.15 LBS	



TITLE		10" - 30" OD RINGMOUNT			
SIZE	SCALE	DOCUMENT NO.			
C	1:1	MC-RM1030-3			
		DRAWING			SHEET
		VERSION	STATUS	REVISION	
Confidential		01	RE	M	

4

3

2

1