

- 1.0 GENERAL NOTES  
 1.1 ALL METRIC DIMENSIONS ARE IN BRACKETS [X. X]  
 1.2 FOR PATENT INFO: <https://www.adwpat.com>
- 2.0 DESIGN NOTES  
 2.1 FITS 90° 6" TO 12" ANGLE, 60° 8" TO 16" ANGLE, 8" TO 16" OD LEGS
- 3.0 MANUFACTURING/SPECIAL REQUIREMENTS  
 3.1 TIGHTEN ALL BOLTS SECURING FLAT PLATES BY THE TURN-OF-NUT METHOD. TIGHTEN ALL U-BOLTS USING TURN-OF-NUT METHOD WITH ATTENTION TO LEAVE EQUAL DISTANCE AND EQUAL FORCE ON EACH LEG OF THE U-BOLT.
- 4.0 TEST
- 5.0 PACKAGING  
 5.1 PACKAGING SHALL MEET ANDREW REQUIREMENTS PER DOCUMENT IS-PL-3005  
 5.2 PRINTED DOCUMENT TO BE PLACED INSIDE POLYBAG AND THEN IN SHIPPING CONTAINER  
 5.3 EXTRA HARDWARE MAY BE SUPPLIED, BAGGED AND SHIPPED

REVISIONS			
REV.	DESCRIPTION	DATE	APPROVED
A	INITIAL RELEASE	OGG 30JUN10	TP
B	UPDATED DRAWING FORMAT	YX1027 21OCT25	BA1025 50105463AMO

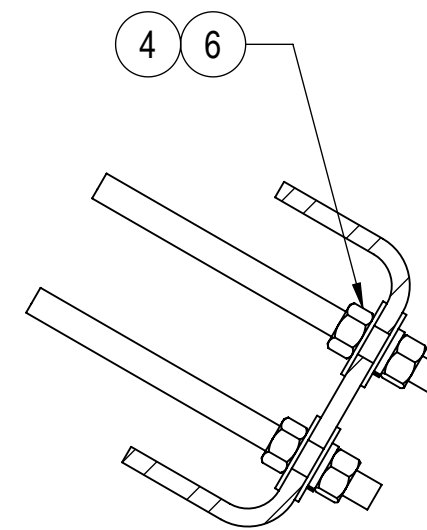

**SECTION A-A**  
SCALE 1 : 4

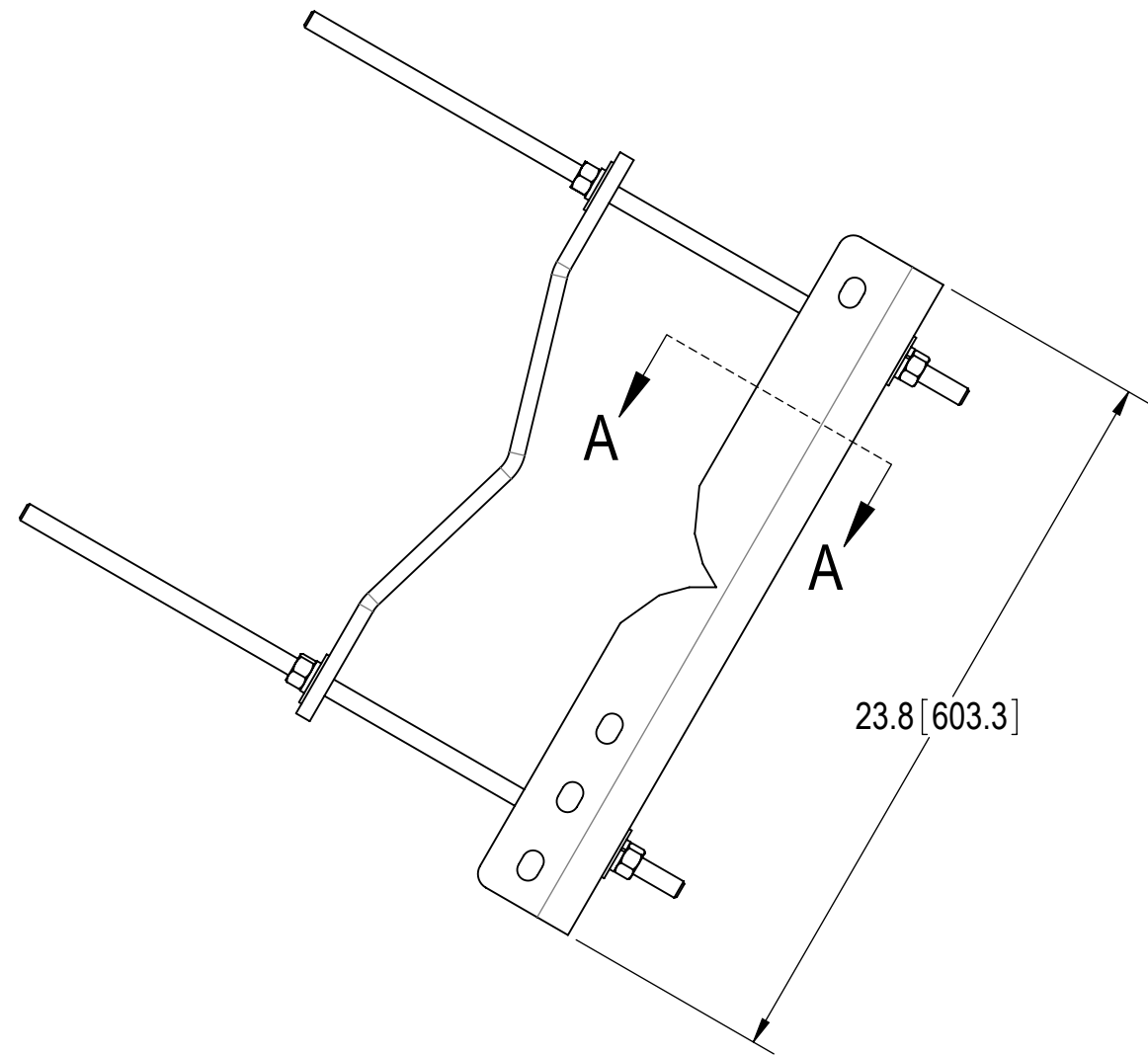
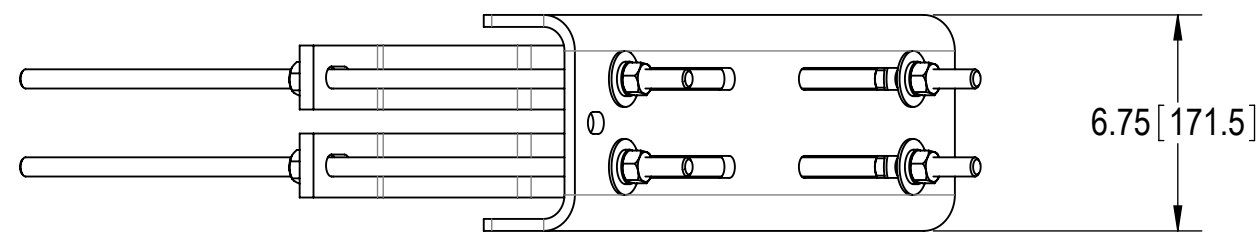
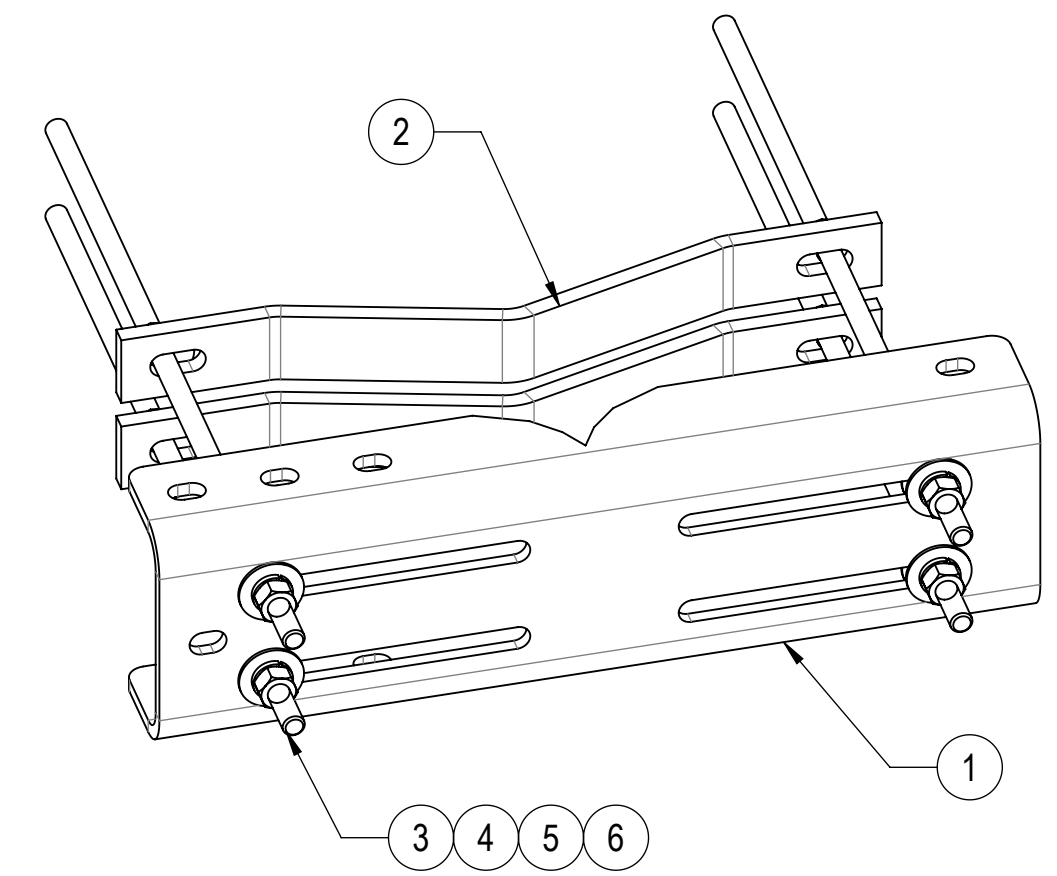

COMPONENT PART NUMBERS PROVIDED FOR ASSEMBLY PURPOSES;  
 INDIVIDUAL COMPONENTS MAY BE SHIPPED AS PARTS WITHIN AN INCLUDED KIT.

ITEM	PART NO.	DESCRIPTION	QTY.	WEIGHT	NOTE NO.
1	MDLCS01	LARGE UNIVERSAL LEG CHANNEL	1	27.16 LBS	
2	MDLCS02	MDLCS HALF CLAMP 6" - 12" 90DEG	2	5.71 LBS	
3	MT-382-24	5/8" X 24" THREADED ROD	4	1.93 LBS	
4	GWF-05	5/8" GALV FLAT WASHER, 1.7OD	12	0.06 LBS	
5	GWL-05	5/8" GALV LOCK WASHER	8	0.03 LBS	
6	GN-05	5/8" GALV HEX NUT	12	0.08 LBS	

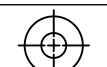
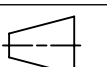

**ANDREW**® an Amphenol company

TOLERANCES		SAP MATERIAL MASTER						
1 PLACE .X[X] ± 0.12[3.0]	3 PLACE .XXX[X] ± 0.03[0.8]	<b>MDL-CS-B</b>						
2 PLACE .XX[X] ± 0.06[1.5]	ANGLES ± 2°							
FINISH		MATERIAL						
UNLESS OTHERWISE SPECIFIED DIMENSIONS ARE IN INCHES INTERPRET PER ANSI Y 14.5M-1994	NAME	DATE	TITLE					
	CE OGG	30JUN10	<b>LARGE MICROWAVE DISH CHANNEL SUPPORT BAS</b>					
	RW YX1027	10/23/2025						
	AD YMENG	10/27/2025	SCALE					
	RE YMENG	10/27/2025	DOCUMENT NO.					
ECN 50105463AMO		<b>MDL-CS-B</b>						
SIZE	Auth Group INSL	MODEL						
C	 	VERSION	STATUS	REVISION	VERSION	STATUS	REVISION	SHEET
		01	RE	C	01	RE	B	1 OF 2

Confidential

# OPTIONAL MOUNTING

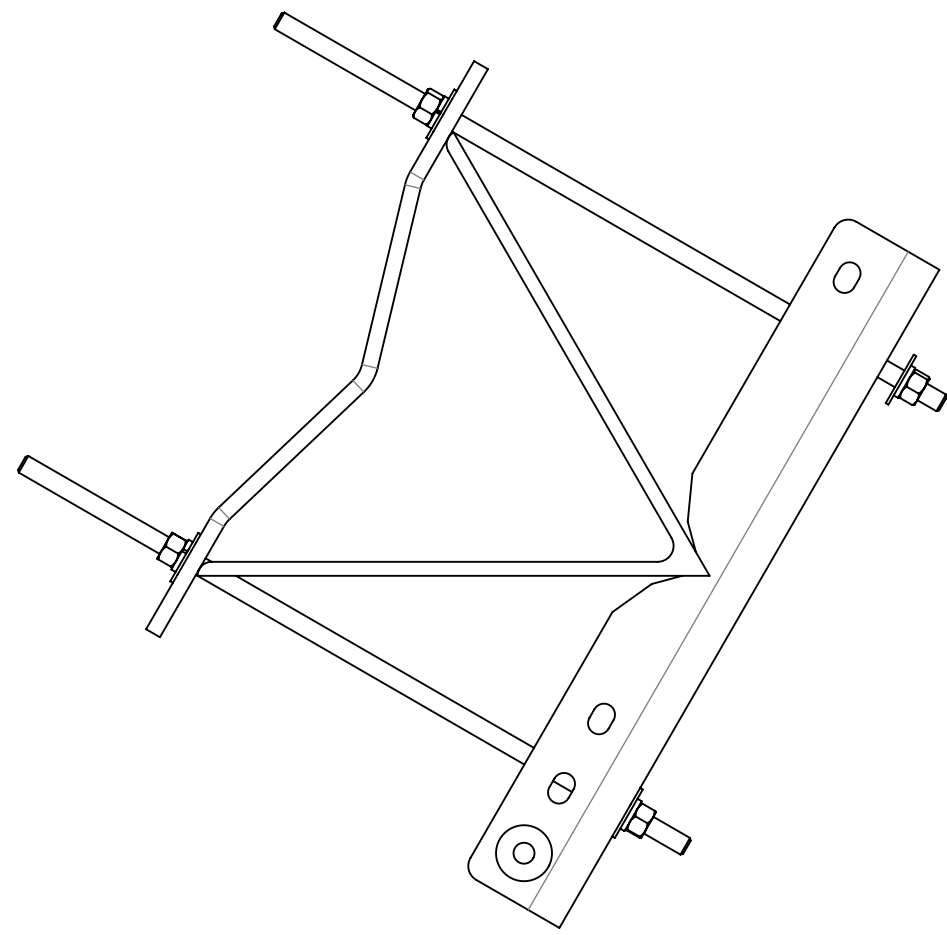

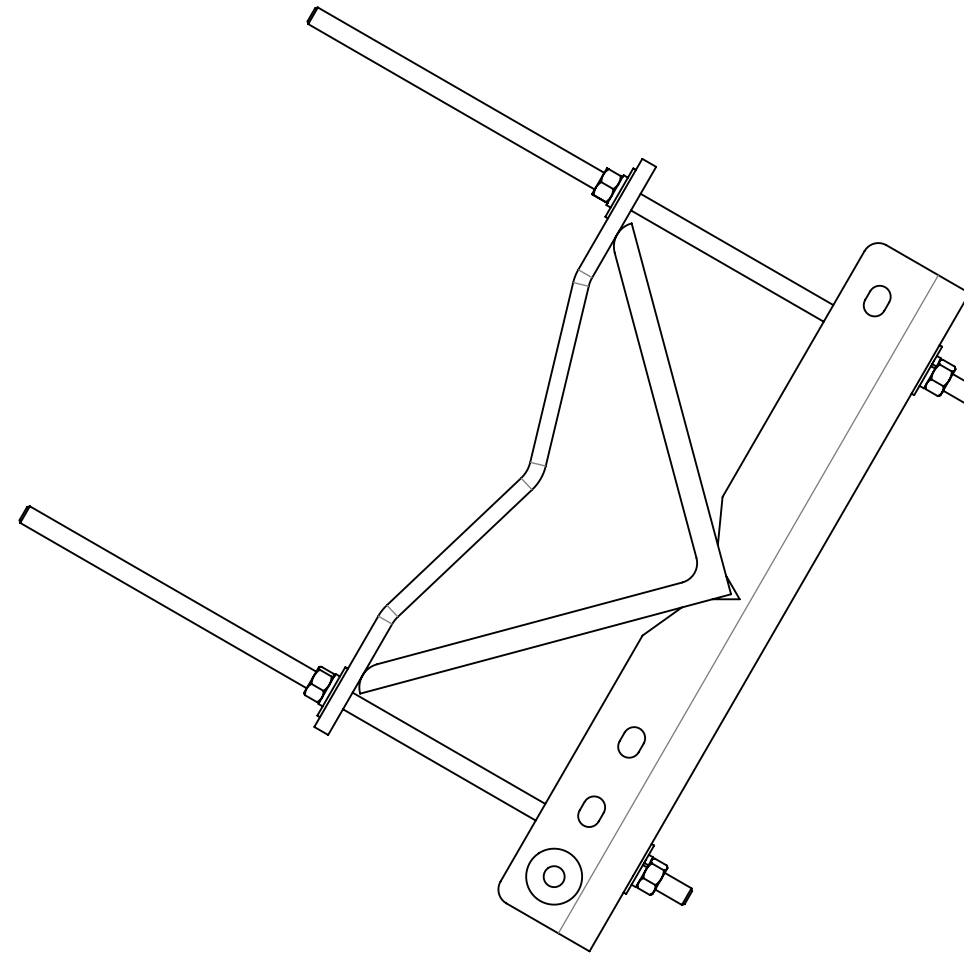

**60 ° TOWER LEGS UP TO 16" X 16" ANGLE**

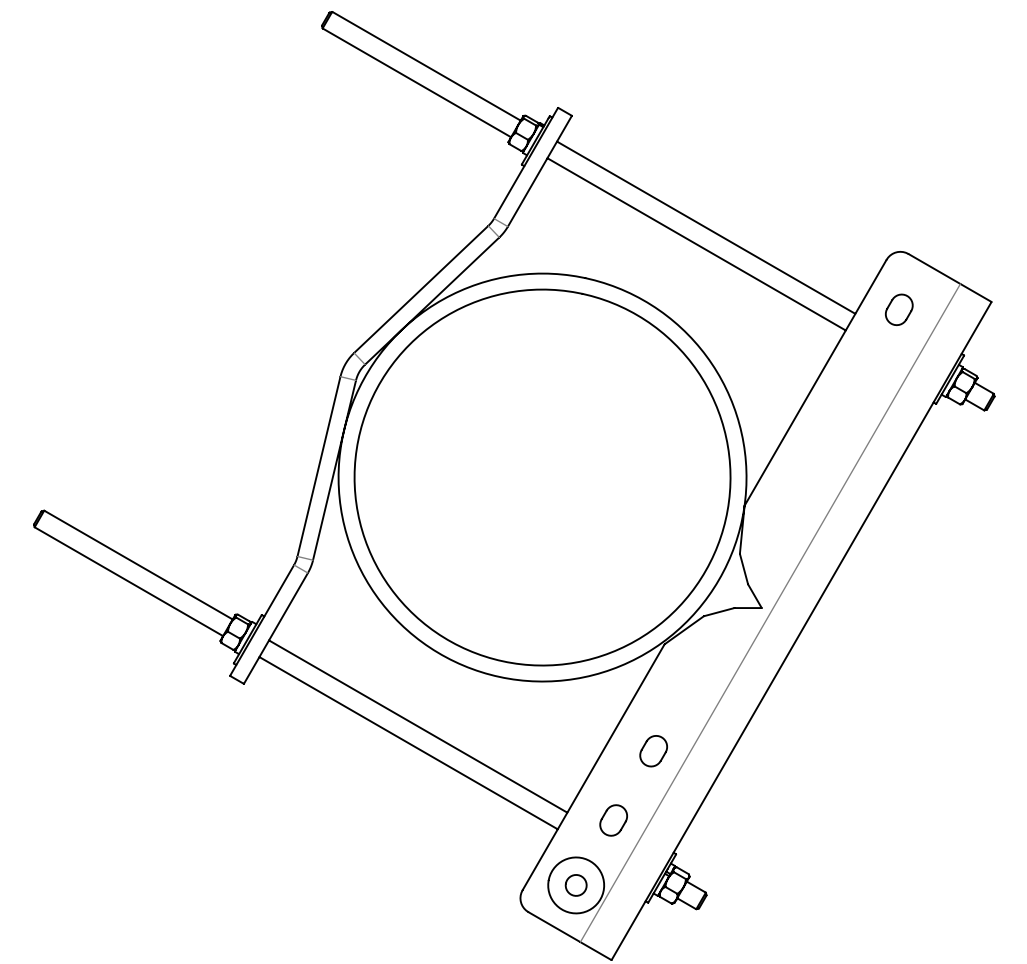

**90 ° TOWER LEGS UP TO 12" X 12" ANGLE**

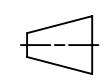

**ROUND TOWER LEGS UP TO  $\phi$  16" OD**

				
TITLE LARGE MICROWAVE DISH CHANNEL SUPPORT BAS				
SIZE <b>C</b>	SCALE <b>1:8</b>	DOCUMENT NO. MDL-CS-B		
 		DRAWING		SHEET
		VERSION	STATUS	REVISION
		01	RE	B
				2 OF 2

Confidential