

- 1.0 GENERAL NOTES
 - 1.1 ALL METRIC DIMENSIONS ARE IN BRACKETS [X.X]
 - 1.2 FOR PATENT INFO: <https://www.adwpat.com>
- 2.0 DESIGN NOTES
- 3.0 MANUFACTURING/SPECIAL REQUIREMENTS
 - 3.1 TIGHTEN ALL BOLTS SECURING FLAT PLATES BY THE TURN-OF-NUT METHOD. TIGHTEN ALL U-BOLTS USING TURN-OF-NUT METHOD WITH ATTENTION TO LEAVE EQUAL DISTANCE AND EQUAL FORCE ON EACH LEG OF THE U-BOLT.
- 4.0 TEST
- 5.0 PACKAGING
 - 5.1 PACKAGING SHALL MEET ANDREW REQUIREMENTS PER DOCUMENT IS-PL-3005
 - 5.2 PRINTED DOCUMENT TO BE PLACED INSIDE POLYBAG AND THEN IN SHIPPING CONTAINER
 - 5.3 EXTRA HARDWARE MAY BE SUPPLIED, BAGGED AND SHIPPED

REVISIONS			
REV.	DESCRIPTION	DATE	APPROVED
A	INITIAL RELEASE	MSM 14APR10	TP
B	THREADED ROD WAS MT-381	MSM 14APR10	TP
C	UPDATED DRAWING FORMAT; REDRAWIN; GWF-05 (ITEM 5) QTY 36 WAS 32, GN-05 (ITEM 7) QTY 24 WAS 20	YC1059 20OCT25	BA1025 50105444AMO

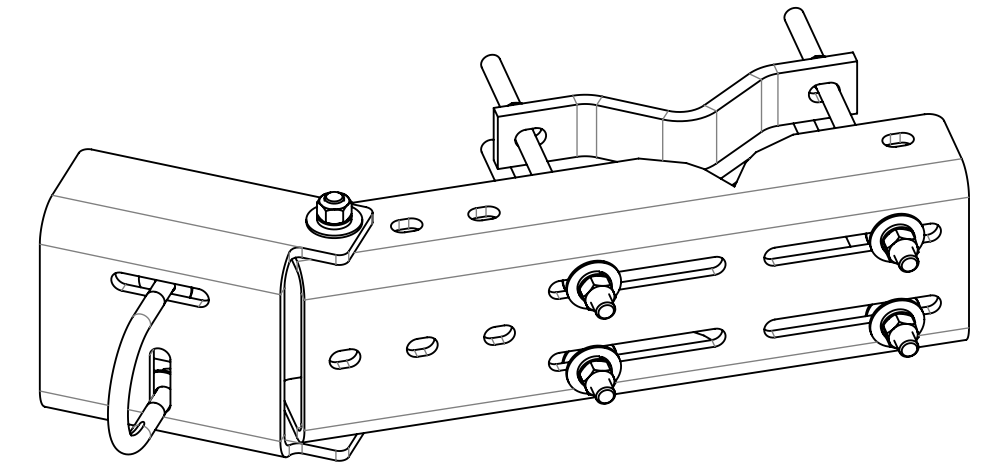
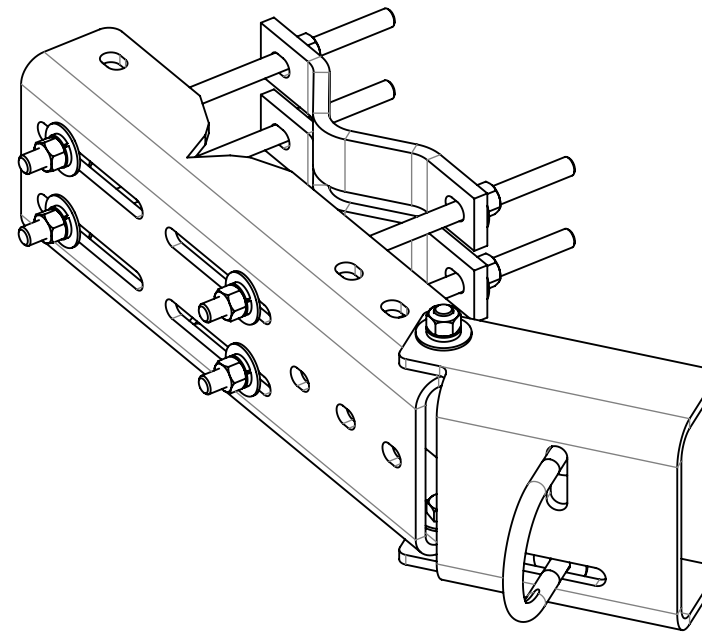
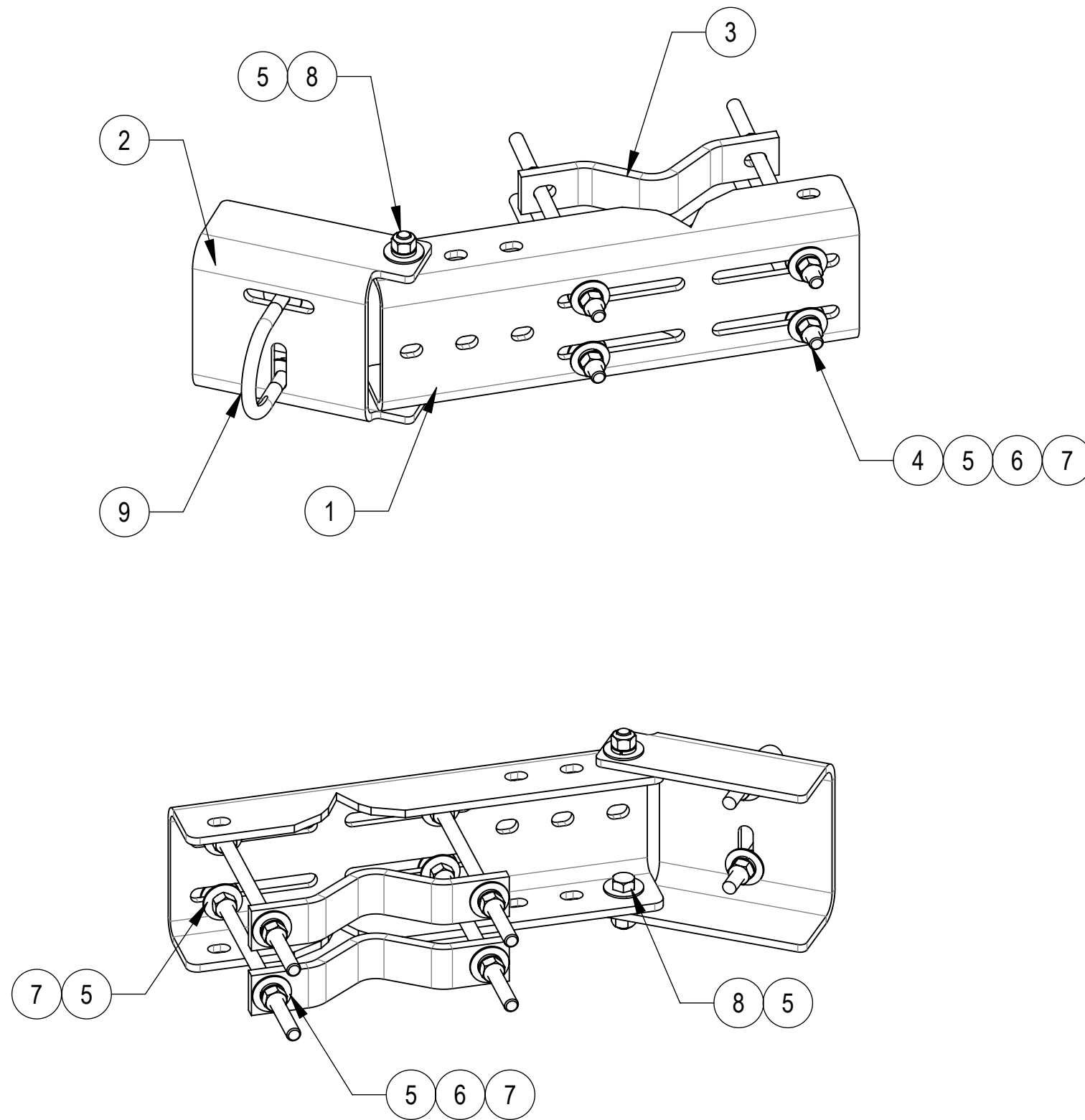

SET-UP WITH U-BOLT ON FACE

COMPONENT PART NUMBERS PROVIDED FOR ASSEMBLY PURPOSES;
INDIVIDUAL COMPONENTS MAY BE SHIPPED AS PARTS WITHIN AN INCLUDED KIT.

ITEM	PART NO.	DESCRIPTION	QTY.	WEIGHT	NOTE NO.
1	MDCS01	UNIVERSAL LEG CHANNEL FOR MD-CS	2	25.05 LBS	
2	MTC987202	CHANNEL PIVOT BRACKET	2	12.43 LBS	
3	MCP10	CLAMP HALF 1/2" 5/8" H/W 2.5-9 PIPE	4	3.40 LBS	
4	MT-382-14	5/8" X 14" GALV THREADED ROD	8	1.21 LBS	
5	GWF-05	5/8" GALV FLAT WASHER, 1.7OD	36	0.06 LBS	
6	GWL-05	5/8" GALV LOCK WASHER	16	0.03 LBS	
7	GN-05	5/8" GALV HEX NUT	24	0.08 LBS	
8	GB-05205	5/8" X 2" GALV BOLT KIT	8	0.26 LBS	
9	GUB-53560	5/8" X 3-5/8" X 6" GALV U-BOLT	2	1.30 LBS	



ANDREW® an Amphenol company

TOLERANCES		SAP MATERIAL MASTER	
1 PLACE .X[X] ± 0.12[3.0]	3 PLACE .XXX[X] ± 0.030[0.8]	MD-CS-F	
2 PLACE .XX[X] ± 0.06[1.5]	ANGLES ± 2°		
FINISH		MATERIAL	
UNLESS OTHERWISE SPECIFIED DIMENSIONS ARE IN INCHES INTERPRET PER ANSI Y 14.5M-1994	NAME	DATE	TITLE
	CE MSM	19APR10	TMW DISH CHANNEL SUPPORT FACE BRACKETS
	RW YC1059	10/22/2025	
	AD YMENG	10/27/2025	
	RE YMENG	10/28/2025	
ECN 50105444AMO			
SCALE	DOCUMENT NO.		MD-CS-F
1:6			
SIZE	Auth Group	INSL	MODEL
C			VERSION STATUS REVISION
			01 RE C
		DRAWING	
		VERSION STATUS REVISION	SHEET
		01 RE C	1 OF 2

Confidential

4

3

2

1

D

D

C

C

B

B

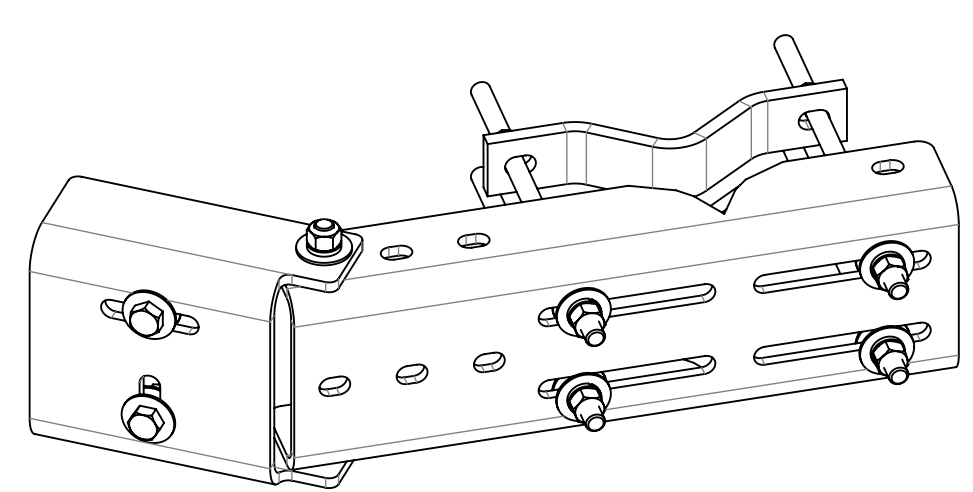
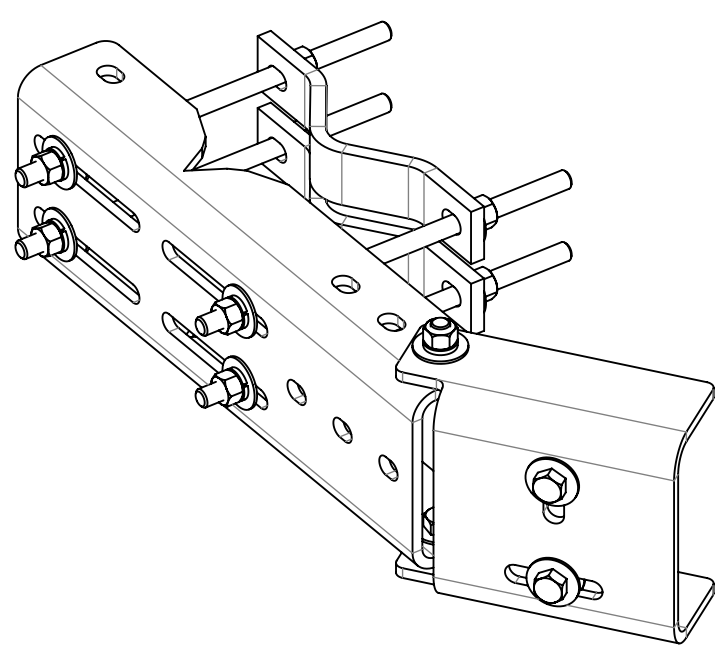
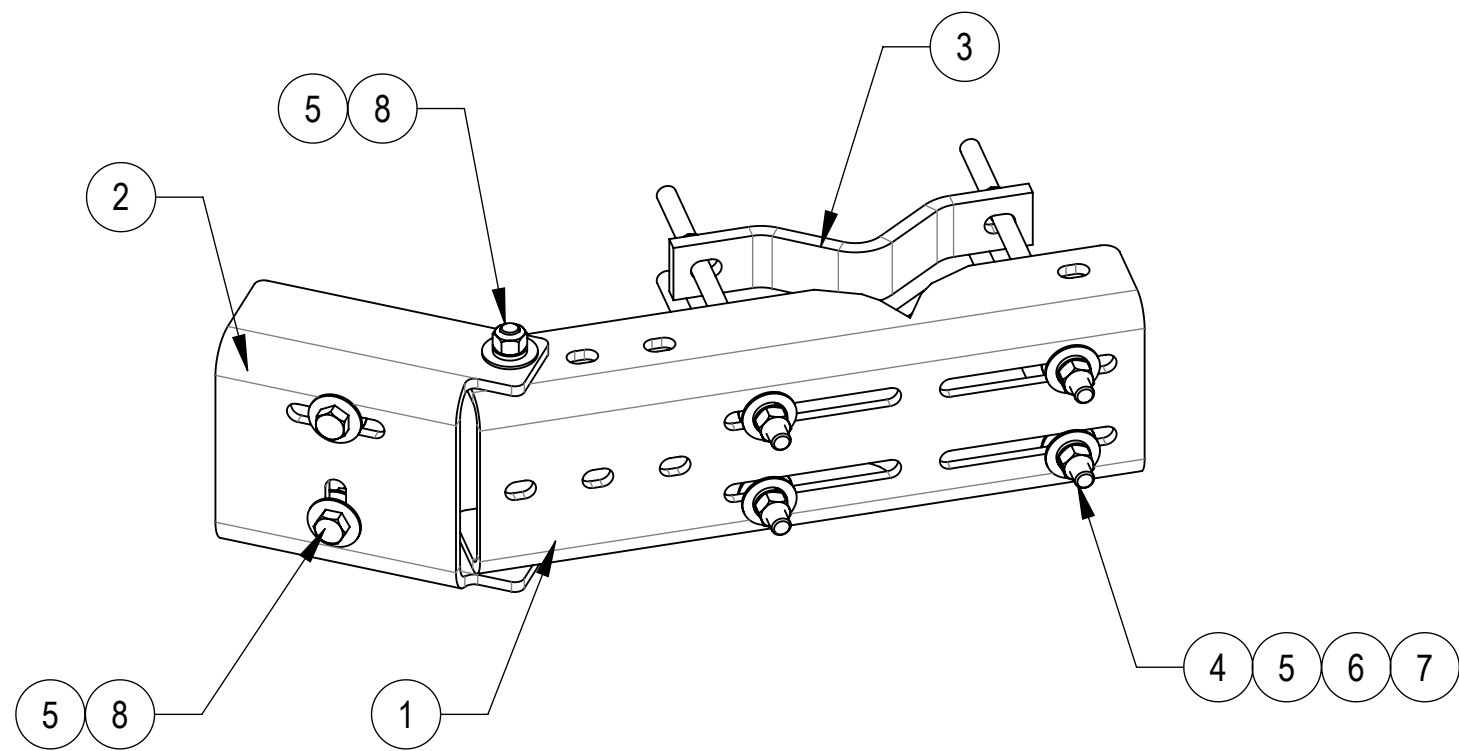

A

A

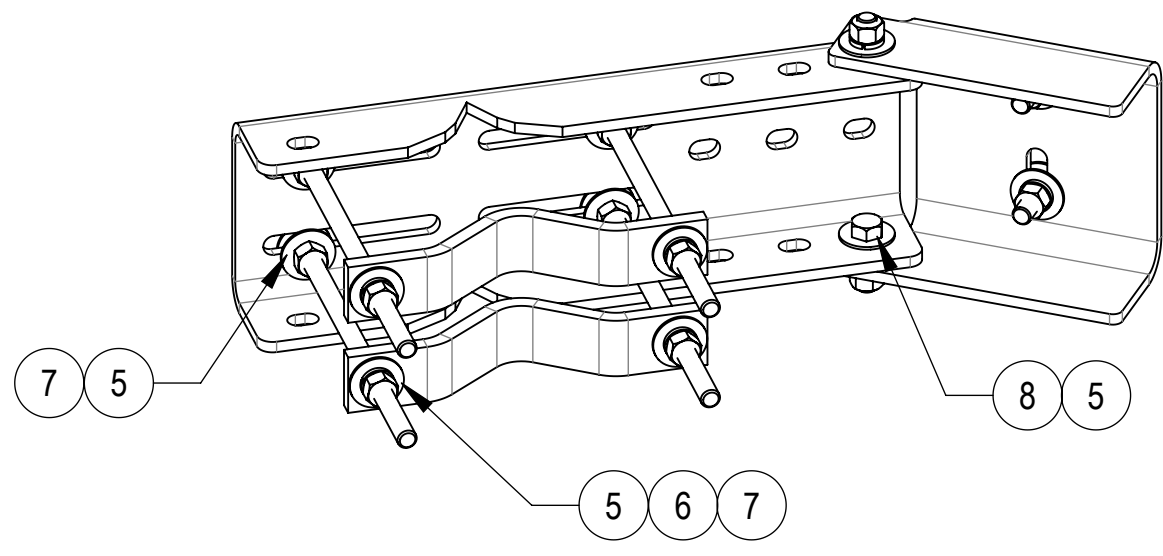

SET-UP WITH BOLTS ON FACE

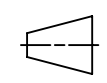

				
TITLE				
TMW DISH CHANNEL SUPPORT FACE BRACKETS				
SIZE	SCALE	DOCUMENT NO.		
C	1:6	MD-CS-F		
 	DRAWING			SHEET
	VERSION	STATUS	REVISION	
		01	RE	C

Confidential

4

3

2

1