

4

3

2

1

1.0 GENERAL NOTES

- 1.1 ALL METRIC DIMENSIONS ARE IN BRACKETS [X.X]
- 1.2 FOR PATENT INFO: <https://www.adwpat.com>

2.0 DESIGN NOTES

2.1 ANY HAZARDS OR OBSTRUCTIONS TO THE CLIMBING FACILITY AND SAFETY CLIMB MUST BE IDENTIFIED PRIOR TO INSTALLING THE APPURTENANCE. ADDITIONAL PRODUCTS MAY BE REQUIRED TO MAINTAIN THE INTEGRITY OF THE SAFETY CLIMB. DURING INSTALLATION, TEMPORARY AND/OR PERMANENT PRECAUTIONARY MEASURES SHOULD BE TAKEN TO PRESERVE THE CLIMBING FACILITY AND/OR SAFETY CLIMB.

3.0 MANUFACTURING/SPECIAL REQUIREMENTS

3.1 TIGHTEN ALL BOLTS SECURING FLAT PLATES BY THE TURN-OF-NUT METHOD.

4.0 TEST

5.0 PACKAGING

- 5.1 PACKAGING SHALL MEET ANDREW REQUIREMENTS PER DOCUMENT IS-PL-3005
- 5.2 PRINTED DOCUMENT TO BE PLACED INSIDE POLYBAG AND THEN IN SHIPPING CONTAINER
- 5.3 EXTRA HARDWARE MAY BE SUPPLIED, BAGGED AND SHIPPED

REVISIONS			
REV.	DESCRIPTION	DATE	APPROVED
B	ADDED BOM	MA 09MAY01	TP
C	UPDATE BOLT SIZE, ADDED FLAT WASHERS, ADDED VIEWS & REDRAWN IN SOLIDWORKS	ACG 17JUL06	TP
D	UPDATED DRAWING FORMAT TO NEW	LL1090 27OCT25	BA1025 50105519AMO

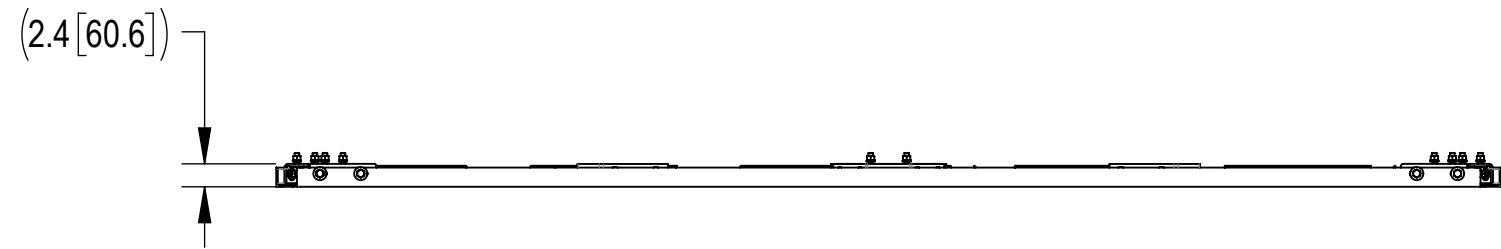
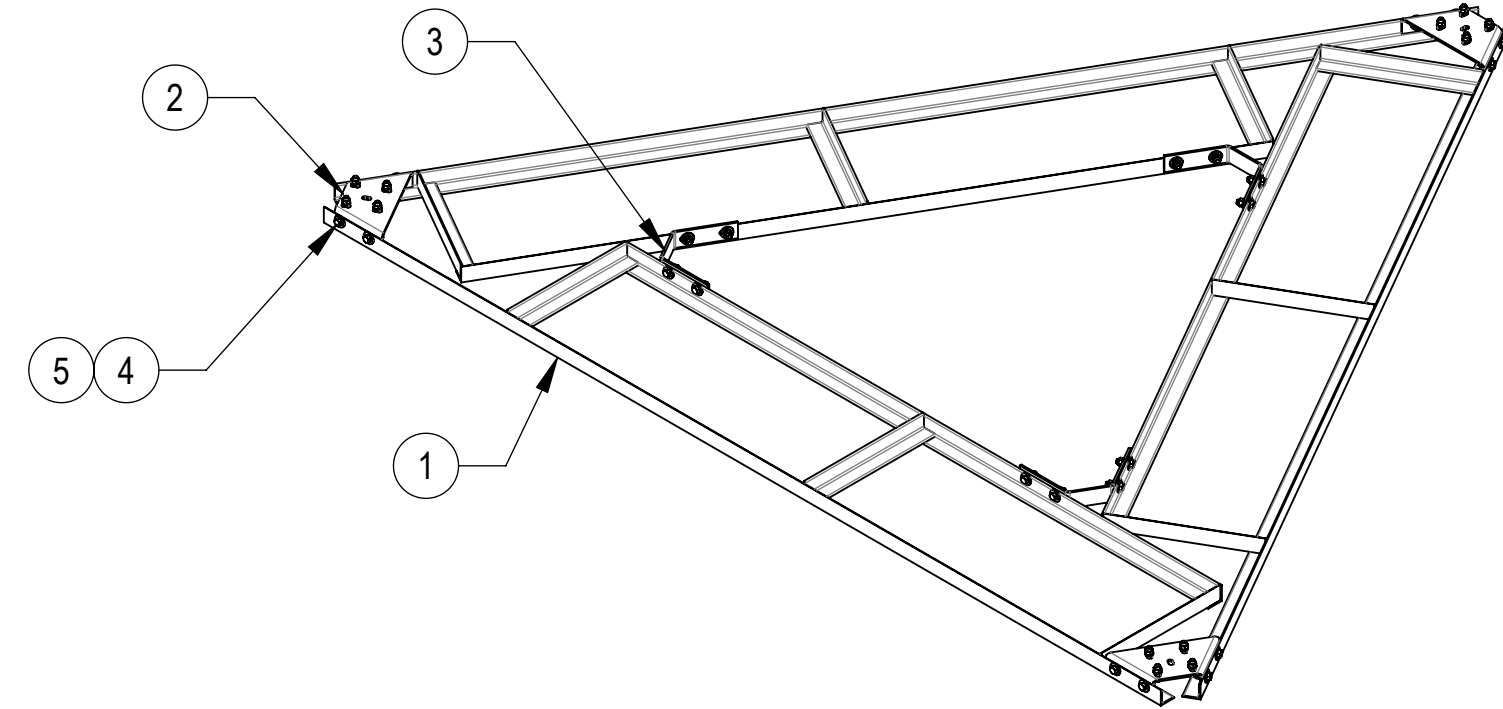
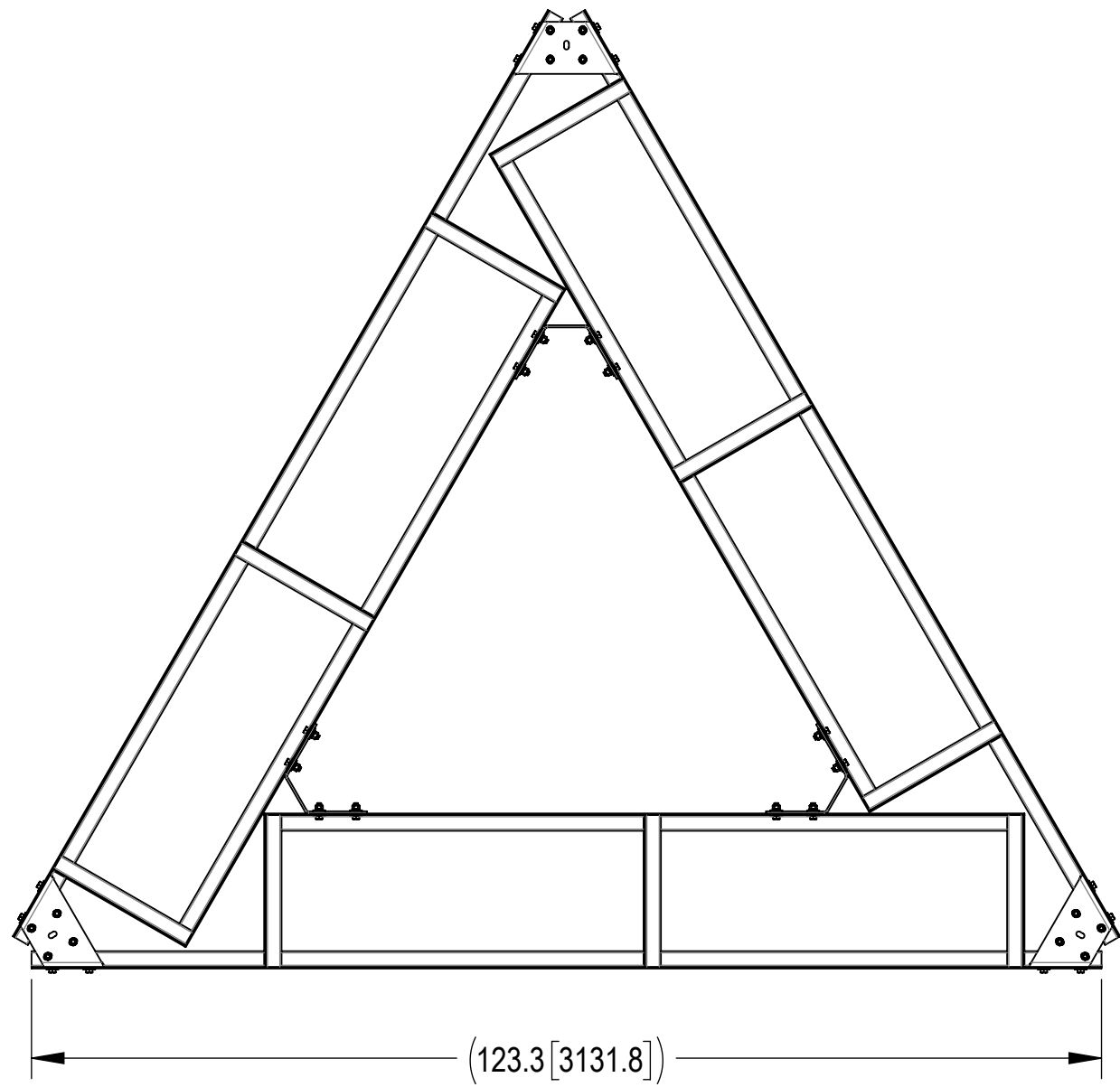

COMPONENT PART NUMBERS PROVIDED FOR ASSEMBLY PURPOSES; INDIVIDUAL COMPONENTS MAY BE SHIPPED AS PARTS WITHIN AN INCLUDED KIT.

ITEM	PART NO.	DESCRIPTION	QTY.	WEIGHT	NOTE NO.
1	MT18101	TRAY, TRIANGULAR BALLAST MOUNT	3	52.28 LBS	
2	MT18102	TRIANGULAR CORNER BRACKET	3	5.01 LBS	
3	MT18103	BALLAST TRAY BENT BRACKET	3	2.49 LBS	
4	GB-04145	1/2" X 1-1/2" GALV BOLT KIT	36	0.13 LBS	
5	GWF-04	1/2" GALV FLAT WASHER	60	0.04 LBS	

DENSITY	MASS	188.36	lbs/in ³
VOLUME		668.43	lbs
SURFACE AREA		7334.43	in ²
HEIGHT		2.4"	
LENGTH		127.6"	
WIDTH		110.5"	



ANDREW® an Amphenol company

TOLERANCES		SAP MATERIAL MASTER	
1 PLACE .X[X] ± 0.2[6.3]	3 PLACE .XXX[X] ± 0.06[1.5]	MT-181	
2 PLACE .XX[X] ± 0.12[3.0]	ANGLES ± 2°		
FINISH		MATERIAL	
<small>UNLESS OTHERWISE SPECIFIED DIMENSIONS ARE IN INCHES INTERPRET PER ANSI Y 14.5M-1994</small>		NAME	DATE
		CE MA	09MAY01
		RW LL1090	10/28/2025
		AD YMENG	10/30/2025
		RE YMENG	10/30/2025
ECN 50105519AMO		TITLE	
		TRIANGULAR MOUNT BALLAST TRAY	
		SCALE	DOCUMENT NO.
		1:16	MT-181
SIZE	Auth Group	INSL	MODEL
C			
VERSION		DRAWING	
01	RE	D	01
		STATUS	REVISION
		RE	D
			SHEET
			1 OF 1

Confidential

4

3

2

1