

4

3

2

1

1.0 GENERAL NOTES

- 1.1 ALL METRIC DIMENSIONS ARE IN BRACKETS [X. X]
- 1.2 FOR PATENT INFO: <https://www.adwpat.com>

2.0 DESIGN NOTES

3.0 MANUFACTURING/SPECIAL REQUIREMENTS

- 3.1 TIGHTEN ALL BOLTS SECURING FLAT PLATES BY THE TURN-OF-NUT METHOD. TIGHTEN ALL U-BOLTS USING TURN-OF-NUT METHOD WITH ATTENTION TO LEAVE EQUAL DISTANCE AND EQUAL FORCE ON EACH LEG OF THE U-BOLT.

4.0 TEST

5.0 PACKAGING

- 5.1 PACKAGING SHALL MEET ANDREW REQUIREMENTS PER DOCUMENT IS-PL-3005
- 5.2 PRINTED DOCUMENT TO BE PLACED INSIDE POLYBAG AND THEN IN SHIPPING CONTAINER
- 5.3 EXTRA HARDWARE MAY BE SUPPLIED, BAGGED AND SHIPPED

REVISIONS			
REV.	DESCRIPTION	DATE	APPROVED
A	INITIAL RELEASE	DI 20JAN05	
B	UPDATE WEIGHT	ACG 12JAN06	
C	REDESIGN ITEM 1 & 2	MSM 27FEB08	
D	CHG BOM ON DRAWING; ADD PACK	CEB 18MAY16	8000014164
E	UPDATED DRAWING FORMAT TO NEW	JJ1095 05NOV25	BA1025 50105693AMO

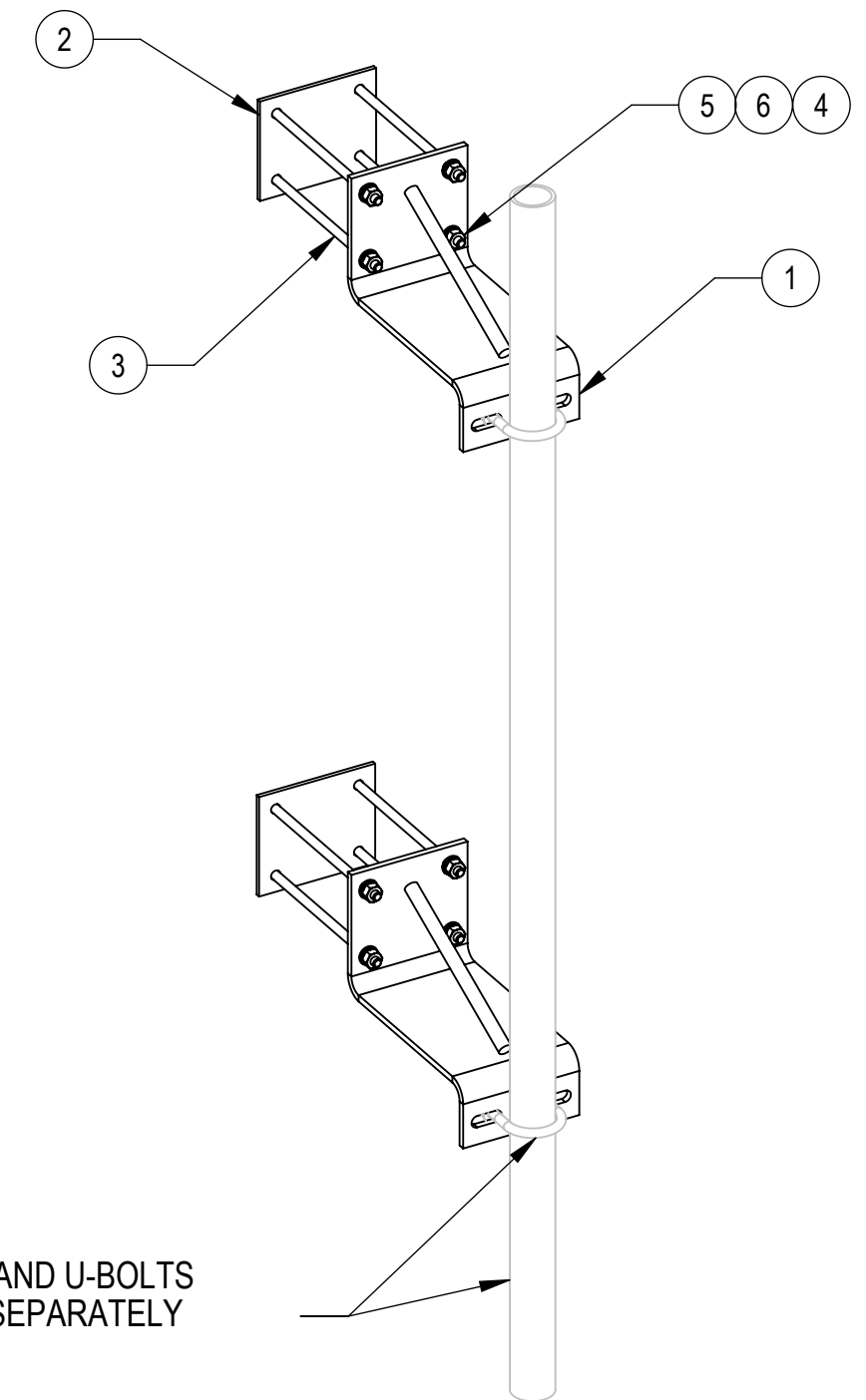
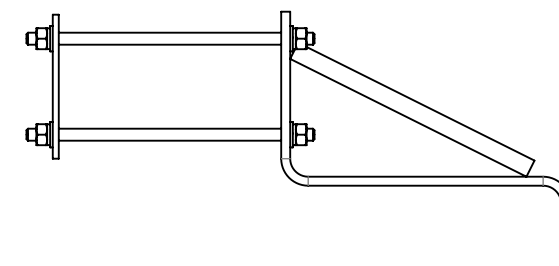
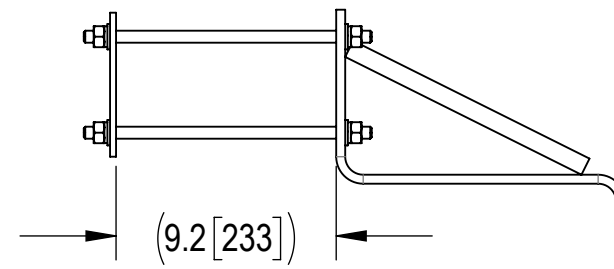
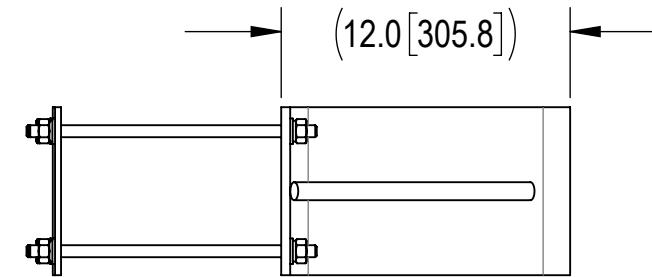
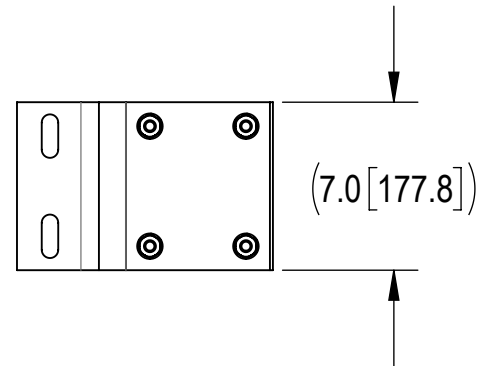
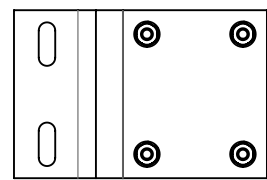

GALV PIPE AND U-BOLTS ORDERED SEPARATELY

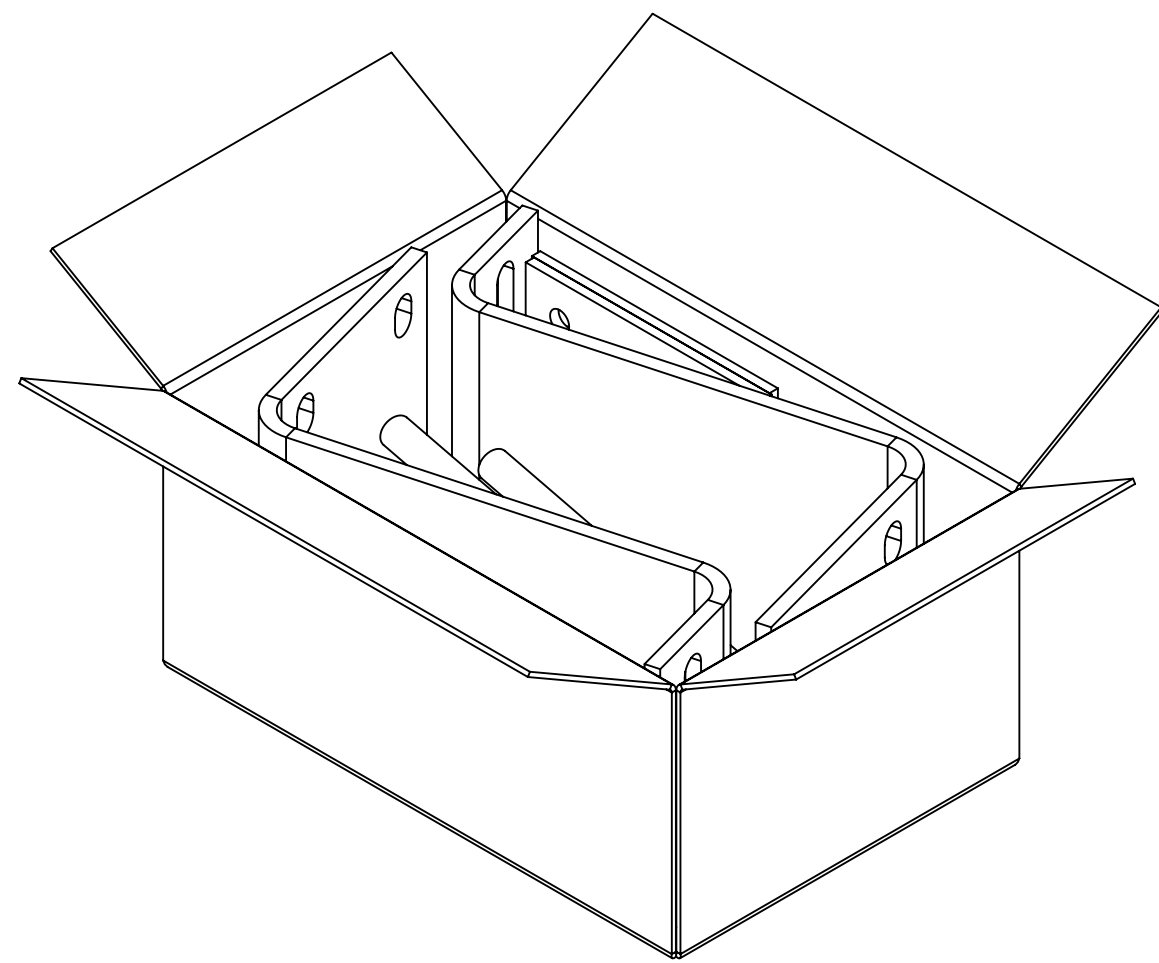

PACKAGE

COMPONENT PART NUMBERS PROVIDED FOR ASSEMBLY PURPOSES; INDIVIDUAL COMPONENTS MAY BE SHIPPED AS PARTS WITHIN AN INCLUDED KIT.



ITEM	PART NO.	DESCRIPTION	QTY.	WEIGHT	NOTE NO.
1	MT221L04	12" WALL MOUNT BRACKET	2	16.80 LBS	
2	MT22303	BACKING PLATE	2	2.89 LBS	
3	MT-379	1/2" X 12" GALV THREADED ROD	8	0.66 LBS	
4	GWFO4A	1/2" GALV FLAT WASHER (A325)	16	0.02 LBS	
5	GN-04A	1/2" GALV HEX NUT (A194 2H)	16	0.07 LBS	
6	GWL-04	1/2" GALV LOCK WASHER	16	0.01 LBS	

DENSITY		lbs/in ³
MASS	75.82	lbs
VOLUME	268.08	in ³
SURFACE AREA	2171.39	in ²
HEIGHT	31.4"	
LENGTH	7.0"	
WIDTH	23.8"	

Confidential



ANDREW® an Amphenol company

TOLERANCES		SAP MATERIAL MASTER	
0 PLACE X[X] ± 0.25[6.4]	2 PLACE .XX[X] ± 0.06[1.5]	MT-221L	
1 PLACE .X[X] ± 0.12[3.0]	ANGLES ± 2°		
FINISH		MATERIAL	
UNLESS OTHERWISE SPECIFIED DIMENSIONS ARE IN INCHES INTERPRET PER ANSI Y 14.5M-1994		NAME	DATE
		CE DI	01/20/2005
		RW JJ1095	11/17/2025
		AD YMENG	11/18/2025
RE YMENG	11/18/2025	ADJ. WALL MOUNT FOR HOLLOW WALLS	
ECN 50105693AMO	SCALE 1:8	DOCUMENT NO. MT-221L	
SIZE	Auth Group	INSL	MODEL
C	 	VERSION	STATUS
		00	RE
		REVISION	VERSION
		D	01
		STATUS	REVISION
		RE	E
			SHEET 1 OF 1

4

3

2

1