

E14F06P38



Twin Diplexer, 1325-1880/1920-2690, dc/AISG pass-through on all ports, with 4.3-10 connectors

- New 4.3-10 connectors for improved PIM performance and size reduction
- Designed for network Modernization, introduction of LTE1800 on existing site
- Designed for network modernization application, introduction of LTE2300 and LTE2600 on existing site
- Twin configuration
- dc/AISG pass-through on all frequency ports

Product Classification

Product Type Diplexer

General Specifications

Color Gray

Modularity 2-Twin

Mounting Pole | Wall

Mounting Pipe Hardware Band clamps (2)

RF Connector Interface 4.3-10 Female

Dimensions

Height 145 mm | 5.709 in

Width 132.5 mm | 5.217 in

Depth 104 mm | 4.094 in

Mounting Pipe Diameter Range 42.6–122 mm

Outline Drawing

E14F06P38

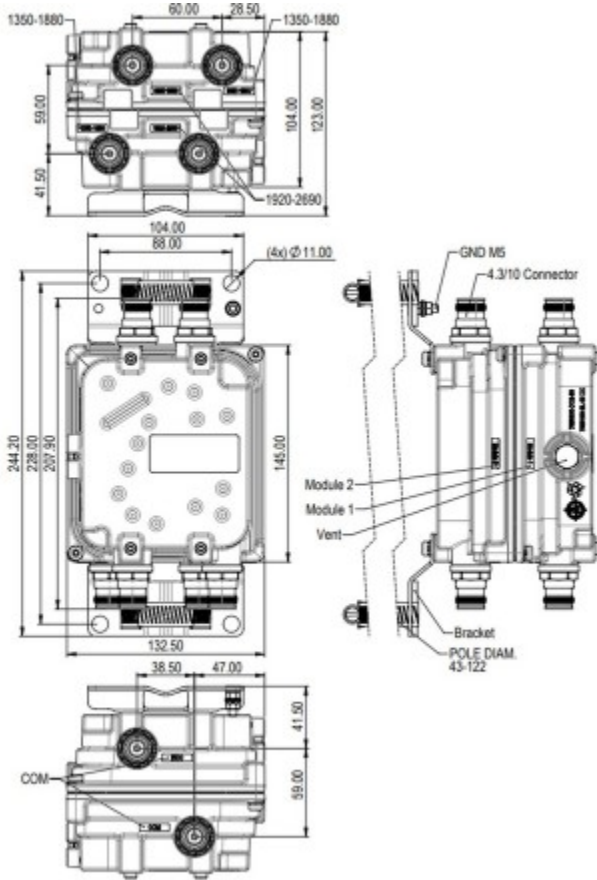

Electrical Specifications

Impedance 50 ohm

Electrical Specifications, dc Power/Alarm

dc/AISG Pass-through, combiner Branch 1 | Branch 2

dc/AISG Pass-through, demultiplexer Branch 1 | Branch 2

Lightning Surge Current 10 kA

Lightning Surge Current Waveform 8/20 waveform

Electrical Specifications

Sub-module	1 2	1 2
Branch	1	2
Port Designation	PORT 1 1350-1880	PORT 2 1920-2690

Electrical Specifications, Band Pass

E14F06P38

Frequency Range, MHz	1350–1880	1920–2690
Insertion Loss, typical, dB	0.25	0.25
Return Loss, typical, dB	20	20
Isolation, typical, dB	52	52
Input Power, RMS, maximum, W	200	200
Input Power, PEP, maximum, W	2000	2000
3rd Order PIM, typical, dBc	-162	-162
3rd Order PIM Test Method	Two +43 dBm carriers	Two +43 dBm carriers

Block Diagram

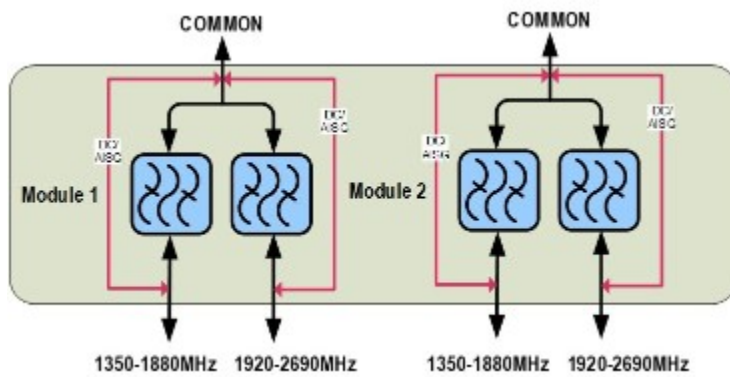

Environmental Specifications

Operating Temperature	-40 °C to +65 °C (-40 °F to +149 °F)
Corrosion Test Method	IEC 60068-2-11, 30 days
Environmental Test Method	ETSI EN 300 019-1-4
Ingress Protection Test Method	IEC 60529:2001, IP67

Packaging and Weights

Included	Mounting hardware
Volume	2 L
Weight, net	2.5 kg 5.512 lb
Weight, with mounting hardware	2.8 kg 6.173 lb