

4

3

2

1

- 1.0 GENERAL NOTES
 - 1.1 ALL METRIC DIMENSIONS ARE IN BRACKETS [X. X]
 - 1.2 FOR PATENT INFO: <https://www.adwpat.com>
- 2.0 DESIGN NOTES
- 3.0 MANUFACTURING/SPECIAL REQUIREMENTS
 - 3.1 TIGHTEN ALL BOLTS SECURING FLAT PLATES BY THE TURN-OF-NUT METHOD. TIGHTEN ALL U-BOLTS USING TURN-OF-NUT METHOD WITH ATTENTION TO LEAVE EQUAL DISTANCE AND EQUAL FORCE ON EACH LEG OF THE U-BOLT.
- 4.0 TEST
- 5.0 PACKAGING
 - 5.1 PACKAGING SHALL MEET ANDREW REQUIREMENTS PER DOCUMENT IS-PL-3005
 - 5.2 PRINTED DOCUMENT TO BE PLACED INSIDE POLYBAG AND THEN IN SHIPPING CONTAINER
 - 5.3 EXTRA HARDWARE MAY BE SUPPLIED, BAGGED AND SHIPPED

REVISIONS			
REV.	DESCRIPTION	DATE	APPROVED
A	INITIAL RELEASE	ADW 13MAR14	
B	ADDED PACKING VIEWS	YMENG 20DEC24	BA1025 40211428CMO

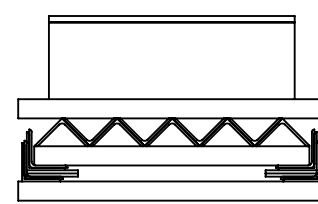
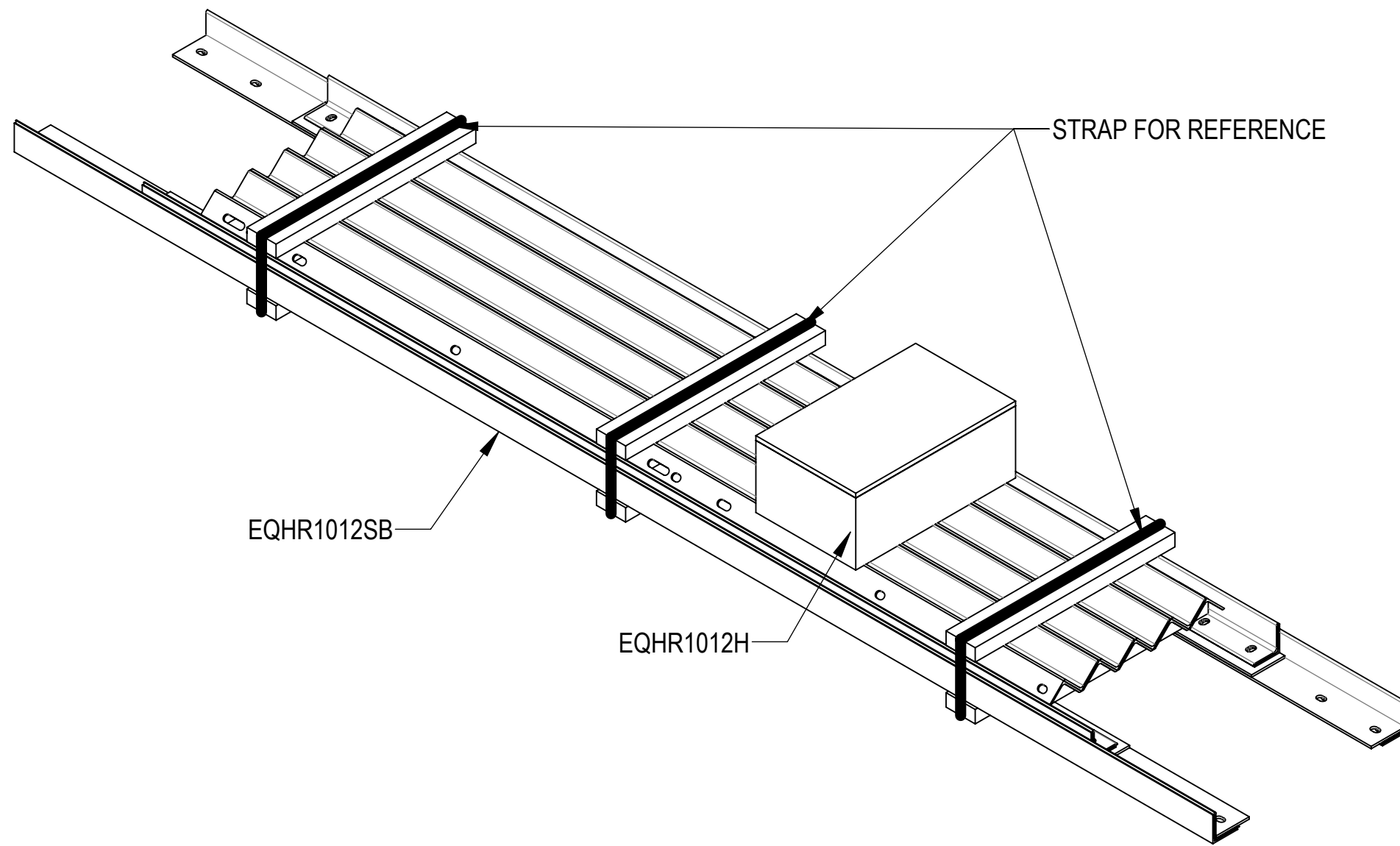
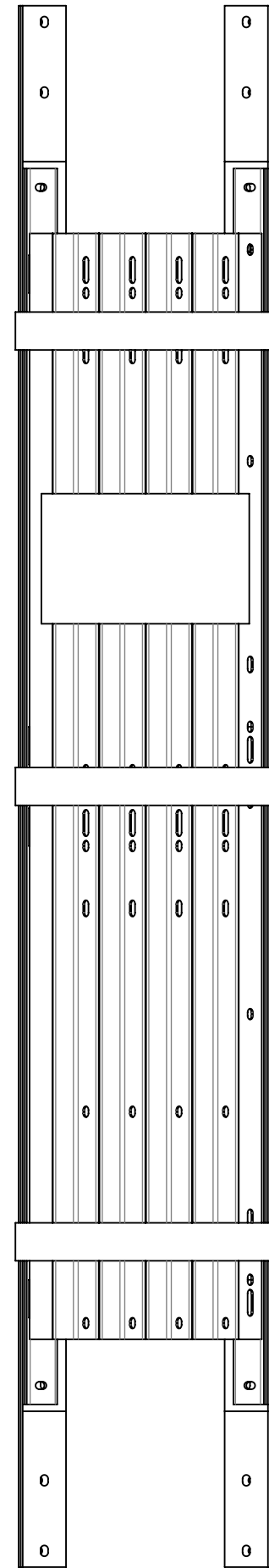



PACKAGE

DENSITY		lbs/in ³
MASS	818.14	lbs
VOLUME	2903.32	in ³
SURFACE AREA	30396.60	in ²
HEIGHT	51"	
LENGTH	144"	
WIDTH	120"	

Confidential



ANDREW® an Amphenol company

TOLERANCES		SAP MATERIAL MASTER						
1 PLACE .X[X] ± 0.2[6.3]	3 PLACE .XXX[X] ± 0.060[1.5]	EQ-HR1012						
2 PLACE .XX[X] ± 0.12[3.0]	ANGLES ± 2°							
FINISH		MATERIAL						
UNLESS OTHERWISE SPECIFIED DIMENSIONS ARE IN INCHES INTERPRET PER ANSI Y 14.5M-1994		NAME	DATE	10' X 12' PLATFORM HANDRAIL KIT				
		CE ADW	13MAR14					
		RW YC1059	06/30/2025					
		AD YMENG	06/30/2025					
		RE YMENG	06/30/2025					
ECN 40211428CMO	SCALE 1:16		DOCUMENT NO. EQ-HR1012					
SIZE	Auth Group	INSL	MODEL	DRAWING		SHEET 1 OF 2		
C			VERSION	STATUS	REVISION		VERSION	STATUS
			00	RE	A	01	RE	B

4

3

2

1

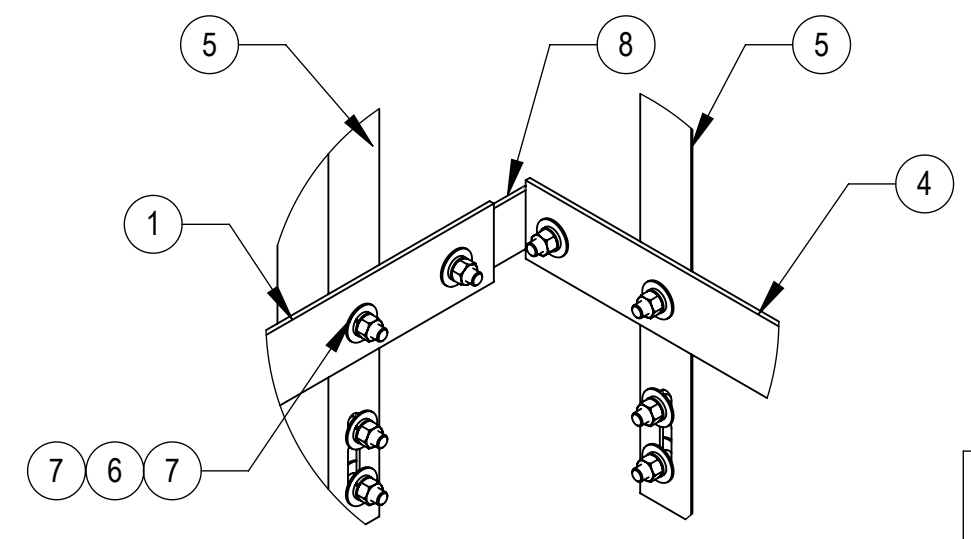
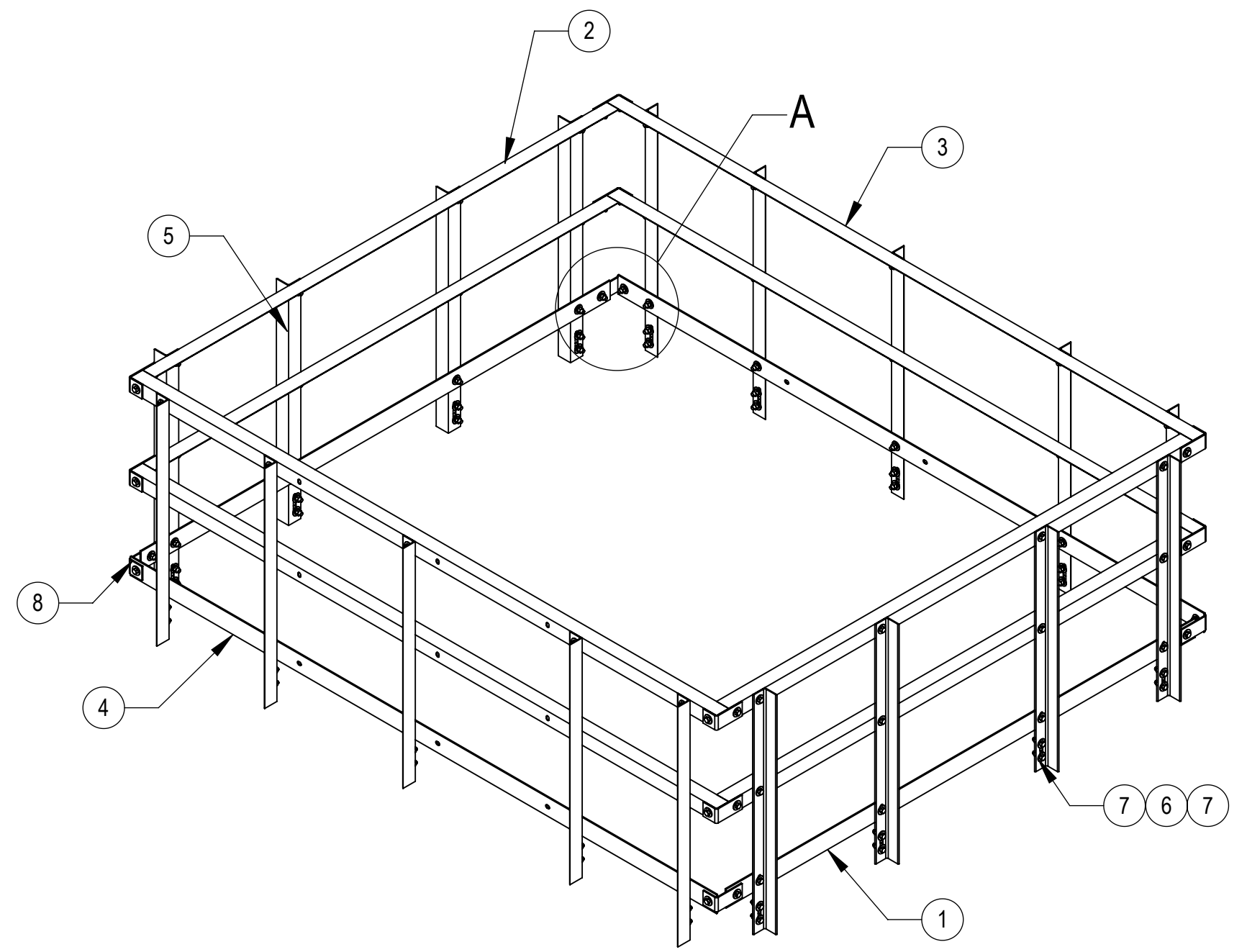
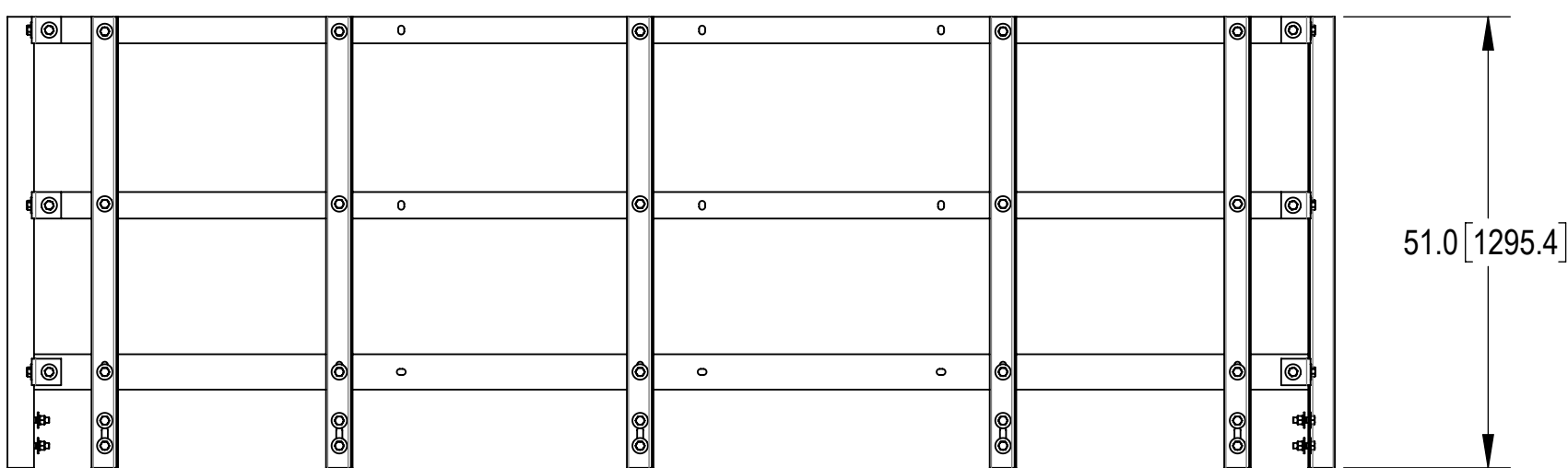
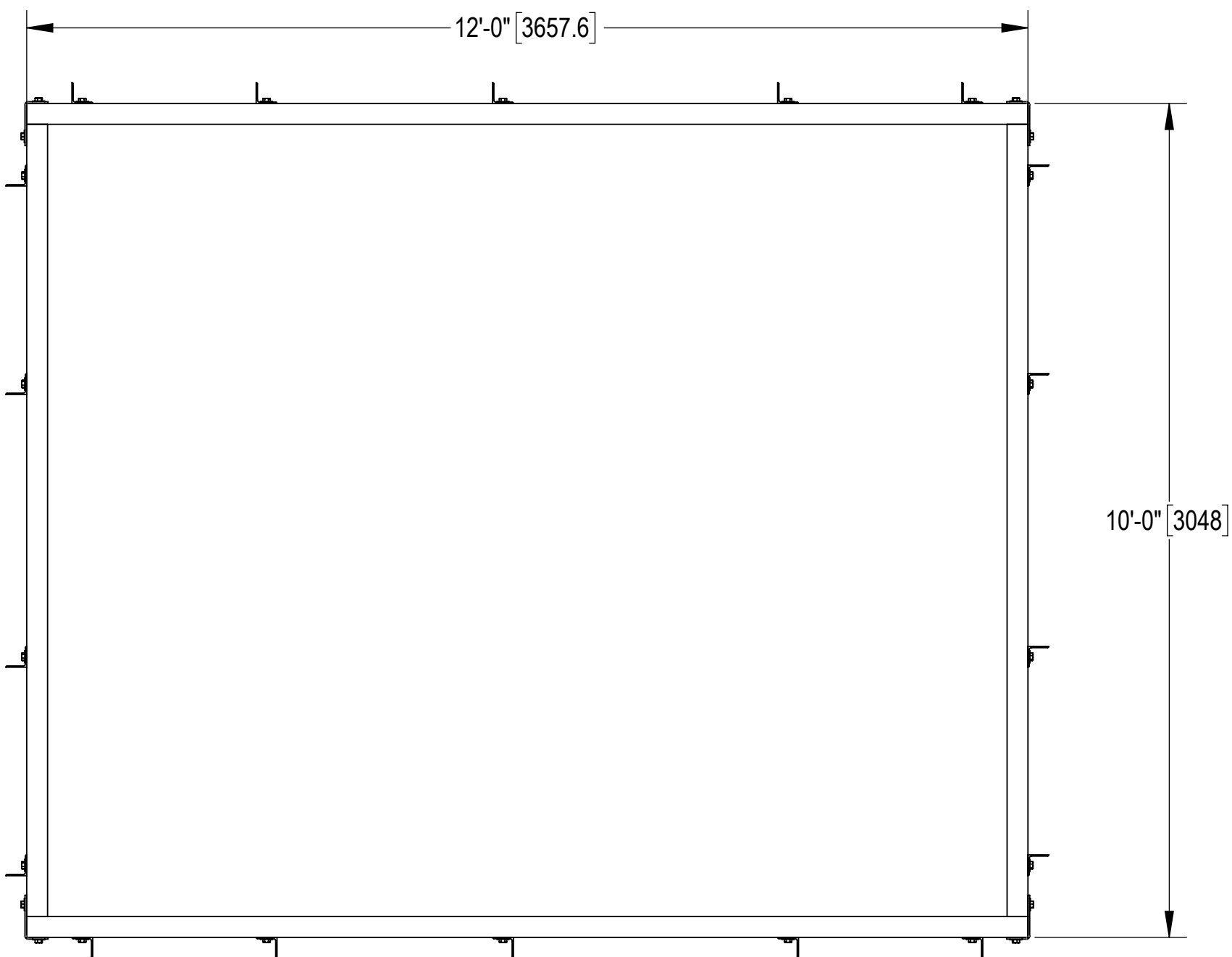

DETAIL A
SCALE 1 : 8

COMPONENT PART NUMBERS PROVIDED FOR ASSEMBLY PURPOSES;
INDIVIDUAL COMPONENTS MAY BE SHIPPED AS PARTS WITHIN AN INCLUDED KIT.

ITEM	PART NO.	DESCRIPTION	QTY.	WEIGHT	NOTE NO.
1	MTC7902101004	10' CENTER TOEBOARD	2	32.23 LBS	
2	MTC7902101005	10' CENTER HANDRAIL	4	35.01 LBS	
3	MTC7902101201	12' SIDE HANDRAIL	4	44.15 LBS	
4	MTC7902101202	12' SIDE TOEBOARD	2	40.17 LBS	
5	EQHR01	HANDRAIL POST	18	15.52 LBS	
6	GB-05205	5/8" X 2" GALV BOLT KIT	114	0.26 LBS	
7	GWF-05	5/8" GALV FLAT WASHER, 1.7OD	228	0.06 LBS	
8	MTC790208	HANDRAIL ANGLE CLIP	12	1.87 LBS	

ANDREW an Amphenol company

TITLE
10' X 12' PLATFORM HANDRAIL KIT

SIZE C	SCALE 1:32	DOCUMENT NO. EQ-HR1012
DRAWING		SHEET
VERSION 01	STATUS RE	REVISION B
		2 OF 2

Confidential