

- 1.0 GENERAL NOTES
 - 1.1 ALL METRIC DIMENSIONS ARE IN BRACKETS [X. X]
 - 1.2 FOR PATENT INFO: <https://www.adwpat.com>
- 2.0 DESIGN NOTES
- 3.0 MANUFACTURING/SPECIAL REQUIREMENTS
 - 3.1 TIGHTEN ALL BOLTS SECURING FLAT PLATES BY THE TURN-OF-NUT METHOD. TIGHTEN ALL U-BOLTS USING TURN-OF-NUT METHOD WITH ATTENTION TO LEAVE EQUAL DISTANCE AND EQUAL FORCE ON EACH LEG OF THE U-BOLT.
- 4.0 TEST
- 5.0 PACKAGING
 - 5.1 PACKAGING SHALL MEET ANDREW REQUIREMENTS PER DOCUMENT IS-PL-3005
 - 5.2 PRINTED DOCUMENT TO BE PLACED INSIDE POLYBAG AND THEN IN SHIPPING CONTAINER
 - 5.3 EXTRA HARDWARE MAY BE SUPPLIED, BAGGED AND SHIPPED

REVISIONS			
REV.	DESCRIPTION	DATE	APPROVED
A	INITIAL RELEASE	ACG 15MAR05	TP
B	REPLACE GWF-05 WITH MT389	ACG 24AUG05	TP
C	UPDATE 5/8" HARDWARE	MSM 02AUG13	TP
D	ADDED PACKAGING VIEW, CHANGED BOM ITEM 9 QUANTITY, REPLACE ITEMS 11 & 12	LS1146 28JUL23	BCROSS 40176129CMO
E	EQPDF16 (ITEM 6) WAS MTC7902AL07	YC1059 25SEP25	YZ1080 50105084AMO

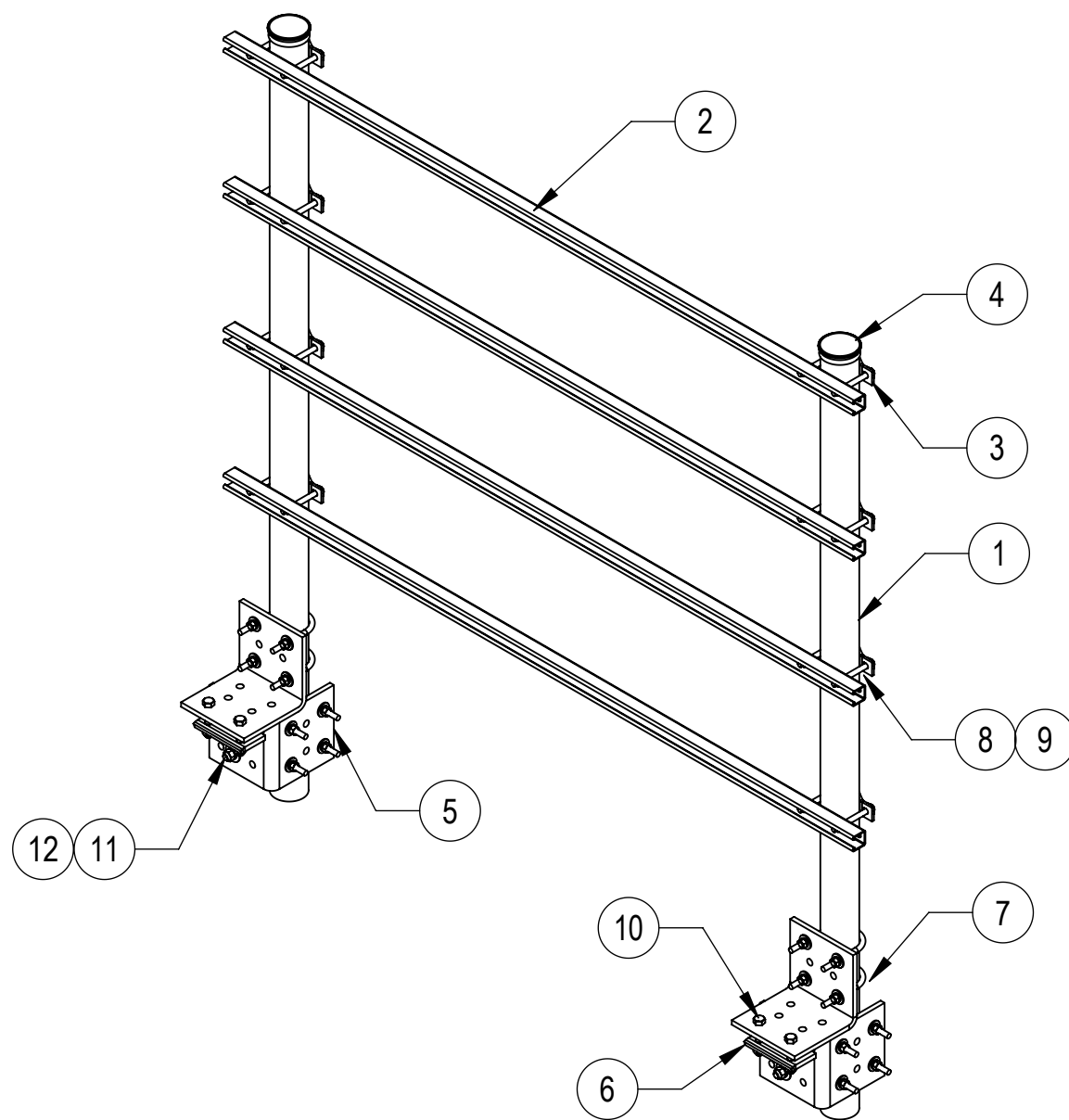
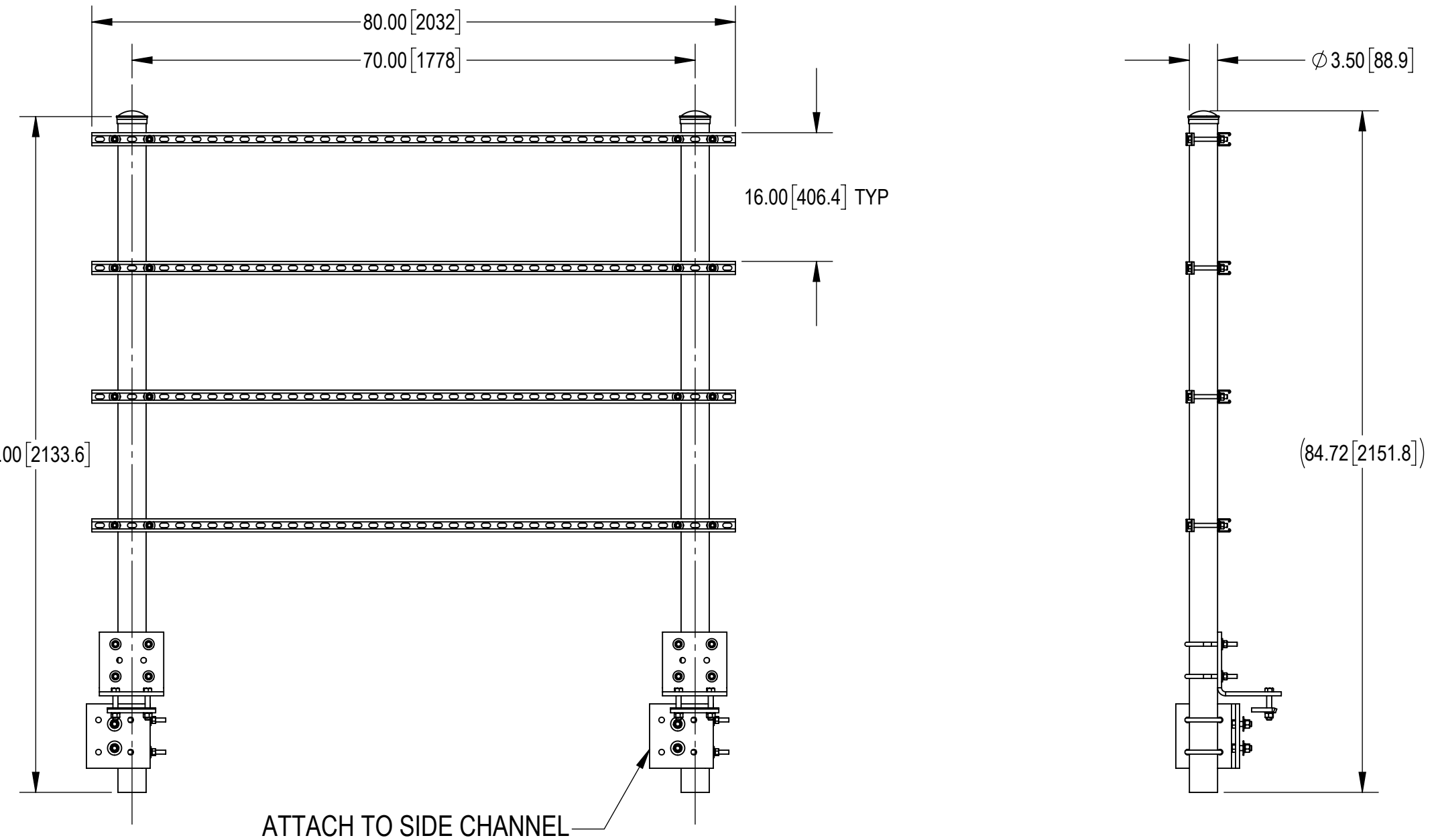
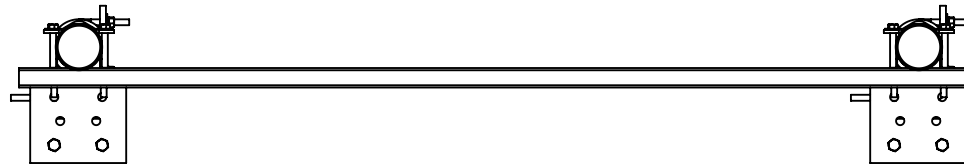

ATTACH UNDER GRATING

ATTACH TO SIDE CHANNEL

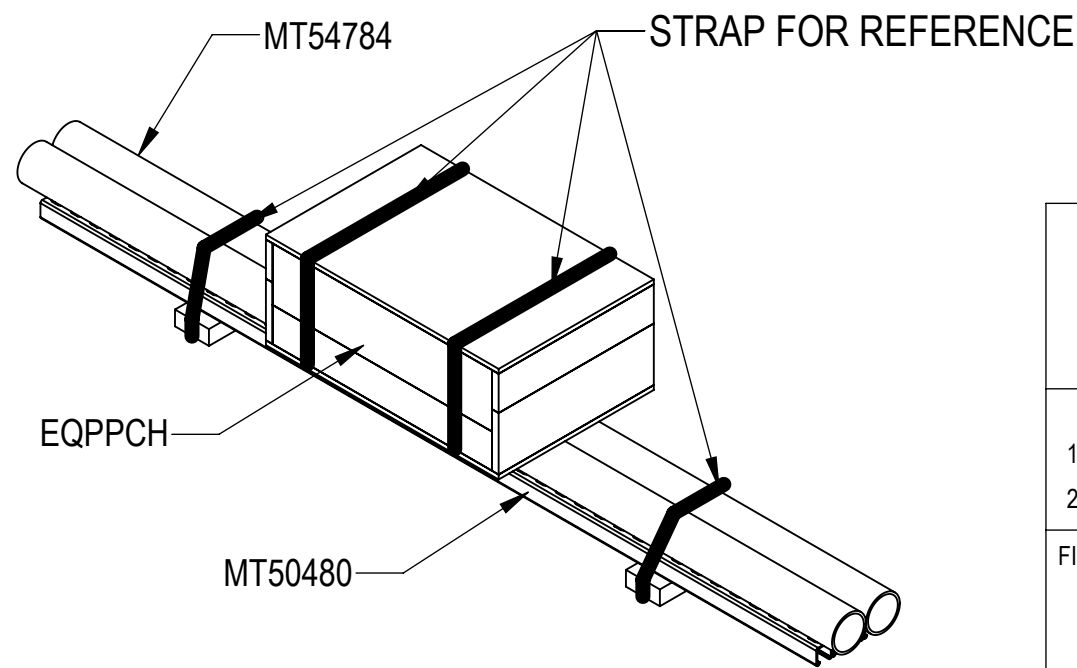

PACKING VIEW

COMPONENT PART NUMBERS PROVIDED FOR ASSEMBLY PURPOSES; INDIVIDUAL COMPONENTS MAY BE SHIPPED AS PARTS WITHIN AN INCLUDED KIT

ITEM	PART NO.	DESCRIPTION	QTY.	WEIGHT	NOTE NO.
1	MT54784	3½" O.D. X 7' GALV. PIPE	2	52.75 LBS	
2	MT50480	UNISTRUT, SLOTTED, GALV, 1-5/8 SQ X 80"	4	13.56 LBS	
3	ACP10	1.5" - 3.5" O.D. CLAMP HALF	8	0.61 LBS	
4	PC-034	PIPE CAP 3-1/2"	2	0.66 LBS	
5	MTC7902TR01	POST BRACKET	4	16.37 LBS	
6	EQPDF16	PINCH PLATE	2	2.49 LBS	
7	GUB-4356	1/2" X 3-5/8" X 6" GALV U-BOLT	8	0.81 LBS	
8	GB-04445	1/2" X 4-1/2" GALV BOLT KIT	16	0.30 LBS	
9	GWF-04	1/2" GALV FLAT WASHER	32	0.04 LBS	
10	GB-05345	5/8" X 3-1/2" GALV BOLT KIT	4	0.39 LBS	
11	GB-05205	5/8" X 2" GALV BOLT KIT	4	0.26 LBS	
12	GWF-05	5/8" GALV FLAT WASHER, 1.70D	4	0.06 LBS	

DENSITY	254.96	lbs/in ³
MASS	254.96	lbs
VOLUME	901.88	in ³
SURFACE AREA	8832.33	in ²
HEIGHT	84.71"	
LENGTH	81.17"	
WIDTH	13.11"	

Confidential



ANDREW® an Amphenol company

TOLERANCES		SAP MATERIAL MASTER	
1 PLACE .X[X] ± 0.06[1.5]	3 PLACE .XXX[X] ± 0.010[0.3]	EQ-PPC	
2 PLACE .XX[X] ± 0.03[0.8]	ANGLES ± 2°		
FINISH		MATERIAL	
UNLESS OTHERWISE SPECIFIED DIMENSIONS ARE IN INCHES INTERPRET PER ANSI Y 14.5M-1994		TITLE	
CE	ACG	17FEB05	TELCO RACK FOR EQUIPMENT PLATFORMS
RW	YC1059	09/26/2025	
AD	YZ1080	09/29/2025	
RE	YMENG	10/09/2025	
ECN 50105084AMO		SCALE	DOCUMENT NO.
		1:24	EQ-PPC
SIZE	Auth Group	INSL	MODEL
C			VERSION
			STATUS
			REVISION
			VERSION
			STATUS
			REVISION
			DRAWING
			VERSION
			STATUS
			REVISION
			SHEET
			1 OF 1